

# CA-IS1204 Isolated Sigma-Delta Modulator for Current Sensing

## 1 Key Features

- Differential Input Voltage Range:  $\pm 250$  mV
- Ultra-Low Input Offset Voltage and Drift
  - $\pm 1$  mV (max) @ 25°C input offset voltage
- Low Gain Error and Drift
  - $\pm 2\%$  (max) @ 25°C gain error
- Excellent AC Performance
  - SNR: 85dB (typ)
  - THD: -91dB (typ)
- Robust Isolation Barrier:  $\pm 150$  kV/ $\mu$ s typical CMTI
- Fault Diagnostic Functions Improve System Safety
- Wide Operating Temperature Range:  $-40^{\circ}\text{C}$  to  $125^{\circ}\text{C}$
- 16-pin wide-body SOIC package
- Safety Regulatory Approvals:
  - 7070  $V_{PK}$  isolation per DIN EN IEC 60747-17 (VDE 0884-17)
  - 5000  $V_{RMS}$  isolation for 1 minute per UL 1577
  - TUV certification approvals

## 2 Applications

- Industrial Motor Controls and Drives
- Uninterruptible Power Supplies (UPS)
- Isolated Power Supply

## 3 Description

The CA-IS1204 device is series of precision isolated sigma-delta ( $\Sigma$ - $\Delta$ ) modulator and optimized for shunt resistor-based current sensing or other small signal measurement applications. The input current-sense amplifier monitors current flow through a shunt (sense) resistor and the sigma-delta modulator converts the analog input to a digital bit stream of 1's and 0's at a much higher frequency. The digital output stage of CA-IS1204 provides uncoded CMOS bit-stream output.

The analog input-side (high-side) and digital output-side (low-side) are separated by unique silicon oxide ( $\text{SiO}_2$ ) capacitive isolation barriers that provide up to  $5kV_{RMS}$  galvanic isolation per UL1577 certification, and isolator driver transfers the modulator output across this isolation barrier. In systems with different voltage domains, this isolation technical is typically used to protect the low voltage side from the high voltage side in case of any faults. These devices also feature up to  $150kV/\mu\text{s}$  common mode transient immunity and enable efficient signal transmission in noisy environments.

The CA-IS1204 device features low input voltage range ( $\pm 250$  mV) that allows the use of small sense resistor to reduce power dissipation, a low ( $\pm 2\%$ , max) gain error ensures measurement accuracy. This device also features fail-safe output to support high safety system design. The device is specified for operation with 5MHz to 21MHz clock input. The internal sigma-delta modulator combined with an external digital decimation sinc3 filter can achieve 85 dB signal-to-noise ratio (SNR) at 78.1 Ksps.

The CA-IS1204W is specified over the  $-40^{\circ}\text{C}$  to  $+125^{\circ}\text{C}$  operating temperature range and is available in 16-pin SOIC wide body package.

### Device Information

Part Number	Package	Body Size (NOM)
CA-IS1204W	SOIC16-WB (W)	10.30 mm $\times$ 7.50 mm

**Simplified Schematic**

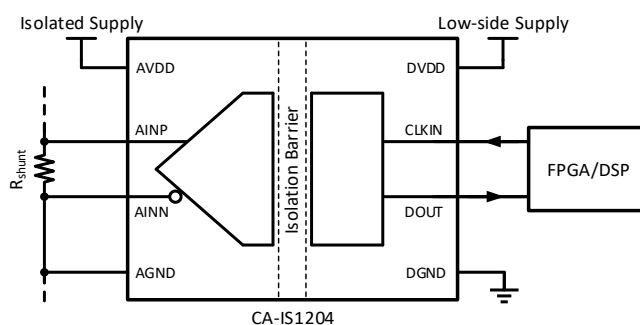

**4 Ordering Information**

**Table 4-1 Valid Parts Ordering Information**

Ordering Part Number	Specified Input Range	Galvanic Isolation ( $V_{RMS}$ )	Package
CA-IS1204W	$\pm 250$ mV	5000	SOIC16-WB(W)

## Table of Contents

<b>1</b>	<b>Key Features</b> .....	<b>1</b>	<b>8.2</b>	Analog Input (High-side) .....	<b>16</b>
<b>2</b>	<b>Applications</b> .....	<b>1</b>	<b>8.3</b>	Signal Isolation .....	<b>17</b>
<b>3</b>	<b>Description</b> .....	<b>1</b>	<b>8.4</b>	Digital Output (Low-side) .....	<b>17</b>
<b>4</b>	<b>Ordering Information</b> .....	<b>2</b>	8.4.1	Bit stream output .....	17
<b>5</b>	<b>Revision History</b> .....	<b>3</b>	8.4.2	Over-range Output .....	18
<b>6</b>	<b>Pin Configuration and Descriptions</b> .....	<b>4</b>	8.4.3	Fail-Safe Output .....	18
<b>7</b>	<b>Specifications</b> .....	<b>5</b>	<b>9</b>	<b>Application Information</b> .....	<b>19</b>
7.1	Absolute Maximum Ratings <sup>1</sup> .....	5	9.1	Typical Application for Current Sense .....	19
7.2	ESD Ratings .....	5	9.1.1	Typical Application Circuit .....	19
7.3	Recommended Operating Conditions .....	5	9.1.2	Choosing Current Sense Resistor .....	20
7.4	Thermal Information .....	5	9.1.3	Analog Input Filter .....	20
7.5	Power Ratings .....	5	9.1.4	Supply Power .....	20
7.6	Insulation Specifications .....	6	9.1.5	Digital Output Filter .....	20
7.7	Safety-Related Certifications .....	7	<b>9.2</b>	<b>Voltage Measurement</b> .....	<b>21</b>
7.8	Electrical Characteristics .....	8	<b>9.3</b>	<b>Announcements</b> .....	<b>22</b>
7.9	Switching Characteristics .....	10	<b>10</b>	<b>Package Information</b> .....	<b>23</b>
7.10	Typical Characteristics and Waveforms .....	11	<b>11</b>	<b>Soldering Temperature (reflow) Profile</b> .....	<b>24</b>
<b>8</b>	<b>Detailed Description</b> .....	<b>16</b>	<b>12</b>	<b>Tape and Reel Information</b> .....	<b>25</b>
8.1	Overview .....	16	<b>13</b>	<b>Important Notice</b> .....	<b>26</b>

### 5 Revision History

Revision Number	Description	Page Changed
Version 1.00	N/A	N/A
Version 1.01	Updated UL Certification information	7
Version 1.02	Updated VDE and TUV Certification information Updated POD information	1, 6, 7 23

## 6 Pin Configuration and Descriptions

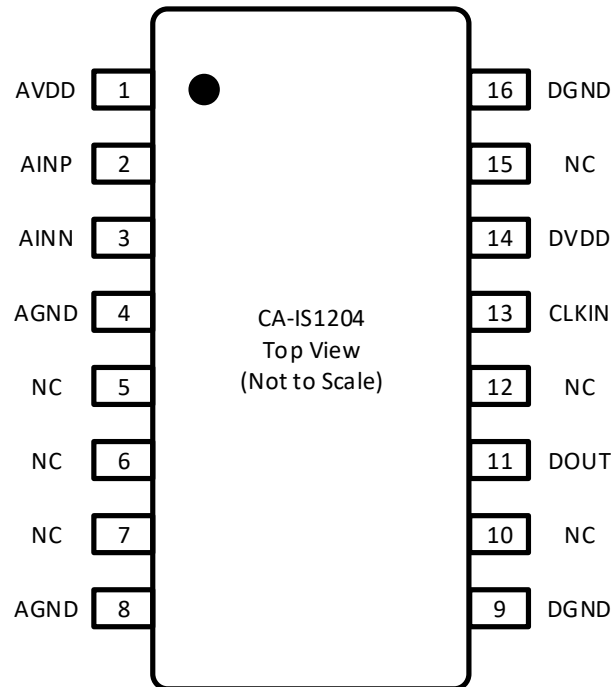

Figure 6-1. CA-IS1204W Top View

Table 6-1. CA-IS1204W Pin Configuration and Description

NAME	Pin #	TYPE	DESCRIPTION
AVDD	1	Power	Power supply input for the input-side (analog input-side), 4.5V to 5.5V. Bypass AVDD to AGND with 0.1 $\mu$ F //2.2 $\mu$ F capacitors as close to the device as possible.
AINP	2	Input	Noninverting analog input. External shunt resistor connection input (power-side) for current sense.
AINN	3	Input	Inverting analog input. External shunt resistor connection input (load-side)for current sense.
AGND	4, 8	Ground	High-side (input-side) ground.
NC	5, 6, 7	---	No connection. Leave them open or connect to AVDD or AGND.
DGND	9, 16	Ground	Low-side (output-side) ground.
NC	10, 12, 15	---	No connection. Leave them open or connect to DVDD or DGND.
DOUT	11	Output	Modulator bit-stream output.
CLKIN	13	Output	Modulator clock input (5 MHz to 21 MHz) with internal 1.5M $\Omega$ pull-down resistor.
DVDD	14	Power	Low-side (digital output-side) power supply, 3.0V to 5.5V. Bypass DVDD to DGND with 0.1 $\mu$ F //2.2 $\mu$ F capacitors as close to the device as possible.

## 7 Specifications

### 7.1 Absolute Maximum Ratings<sup>1</sup>

PARAMETER		MIN	MAX	UNIT
AVDD, DVDD	Supply voltage <sup>2</sup>	-0.5	6.5	V
AINP, AINN	Analog input voltage	AGND - 6	6.5	V
CLKIN, DOUT	Digital input or output voltage	DGND - 0.5	DVDD + 0.5 <sup>3</sup>	V
I <sub>IN</sub>	Input current to any pin except supply pins	-10	10	mA
T <sub>J</sub>	Junction Temperature		150	°C
T <sub>STG</sub>	Storage Temperature	-65	150	°C

#### Notes:

- The stresses listed under "Absolute Maximum Ratings" are stress ratings only, not for functional operation condition. Exposure to absolute maximum rating conditions for extended periods may cause permanent damage to the device.
- All voltage values are with respect to the local ground terminal (AGND or DGND) and are peak voltage values.
- Maximum voltage must not exceed 6.5V.

### 7.2 ESD Ratings

		VALUE	UNIT
V <sub>ESD</sub>	Electrostatic discharge		
	Human body model (HBM), per ANSI/ESDA/JEDEC JS-001, all pins <sup>1</sup>	±4000	V
Charged device model (CDM), per JEDEC specification JESD22-C101, all pins <sup>2</sup>	±2000		

#### Notes:

- Per JEDEC document JEP155, 500V HBM allows safe manufacturing of standard ESD control process.
- Per JEDEC document JEP157, 250V CDM allows safe manufacturing of standard ESD control process.

### 7.3 Recommended Operating Conditions

PARAMETER		MIN	NOM	MAX	UNIT
AVDD	High-side (analog input) supply voltage, with respect to AGND	4.5	5.0	5.5	V
DVDD	Low-side (digital output) supply voltage, with respect to DGND	3.0	3.3	5.5	V
T <sub>A</sub>	Operating ambient temperature range	-40		125	°C

### 7.4 Thermal Information

THERMAL METRIC		VALUE	UNIT
R <sub>θJA</sub>	Junction-to-ambient thermal resistance	86.5	°C/W

### 7.5 Power Ratings

PARAMETER	TEST CONDITIONS	VALUE	UNIT
P <sub>D</sub>	Maximum power dissipation for both sides	AVDD = DVDD = 5.5 V	123.75
P <sub>D1</sub>	Maximum power dissipation for high-side	AVDD = 5.5 V	85.25
P <sub>D2</sub>	Maximum power dissipation for low-side	DVDD = 5.5 V	38.5

**7.6 Insulation Specifications**

PARAMETR		TEST CONDITIONS	VALUE	UNIT
CLR	External clearance <sup>1</sup>	Shortest terminal-to-terminal distance through air	8	mm
CPG	External creepage <sup>1</sup>	Shortest terminal-to-terminal distance across the package surface	8	mm
DTI	Distance through the insulation	Minimum internal gap (internal clearance)	28	μm
CTI	Comparative tracking index	DIN EN 60112 (VDE 0303-11); IEC 60112	> 600	V
	Material group	According to IEC 60664-1	I	
	Overvoltage category per IEC 60664-1	Rated mains voltage ≤ 300 V <sub>RMS</sub>	I-IV	
		Rated mains voltage ≤ 600 V <sub>RMS</sub>	I-IV	
		Rated mains voltage ≤ 1000 V <sub>RMS</sub>	I-III	
<b>DIN EN IEC 60747-17 (VDE 0884-17)<sup>2</sup></b>				
V <sub>IORM</sub>	Maximum repetitive peak isolation voltage	AC voltage (bipolar)	1414	V <sub>PK</sub>
V <sub>IOWM</sub>	Maximum working isolation voltage	AC voltage; Time dependent dielectric breakdown (TDDb) Test	1000	V <sub>RMS</sub>
		DC voltage	1414	V <sub>DC</sub>
V <sub>IOTM</sub>	Maximum transient isolation voltage	V <sub>TEST</sub> = V <sub>IOTM</sub> , t = 60 s (qualification); V <sub>TEST</sub> = 1.2 × V <sub>IOTM</sub> , t = 1 s (100% production)	7070	V <sub>PK</sub>
V <sub>IOSM</sub>	Maximum surge isolation voltage <sup>3</sup>	Test method per IEC 60065, 1.2/50 μs waveform, V <sub>TEST</sub> = 1.6 × V <sub>IOSM</sub> (qualification)	8000	V <sub>PK</sub>
Q <sub>pd</sub>	Apparent charge <sup>4</sup>	Method a, After input/output safety test subgroup 2/3, V <sub>ini</sub> = V <sub>IOTM</sub> , t <sub>ini</sub> = 60 s; V <sub>pd(m)</sub> = 1.2 × V <sub>IORM</sub> , t <sub>m</sub> = 10 s	≤ 5	pC
		Method a, After environmental tests subgroup 1, V <sub>ini</sub> = V <sub>IOTM</sub> , t <sub>ini</sub> = 60 s; V <sub>pd(m)</sub> = 1.6 × V <sub>IORM</sub> , t <sub>m</sub> = 10 s	≤ 5	
		Method b1, At routine test (100% production) and preconditioning (type test) V <sub>ini</sub> = 1.2 × V <sub>IOTM</sub> , t <sub>ini</sub> = 1 s; V <sub>pd(m)</sub> = 1.875 × V <sub>IORM</sub> , t <sub>m</sub> = 1 s	≤ 5	
C <sub>IO</sub>	Barrier capacitance, input to output <sup>5</sup>	V <sub>IO</sub> = 0.4 × sin(2πft), f = 1 MHz	~ 1	pF
R <sub>IO</sub>	Isolation resistance <sup>4</sup>	V <sub>IO</sub> = 500 V, T <sub>A</sub> = 25°C	> 10 <sup>12</sup>	Ω
		V <sub>IO</sub> = 500 V, 100°C ≤ T <sub>A</sub> ≤ 125°C	> 10 <sup>11</sup>	
		V <sub>IO</sub> = 500 V at T <sub>S</sub> = 150°C	> 10 <sup>9</sup>	
	Pollution degree		2	
<b>UL 1577</b>				
V <sub>ISO</sub>	Maximum withstanding isolation voltage	V <sub>TEST</sub> = V <sub>ISO</sub> , t = 60s (qualification), V <sub>TEST</sub> = 1.2 × V <sub>ISO</sub> , t = 1s (100% production)	5000	V <sub>RMS</sub>
<b>Notes:</b>				
1. Apply creepage distance and clearance requirements according to application-specific equipment isolation standards. Take care to maintain the creepage distance and clearance distance of the circuit board design to ensure that the isolator mounting pad on the printed circuit board does not shorten the distance. In some cases the creepage distance and gap on the printed circuit board become equal. Techniques such as inserting grooves into printed circuit boards are used to help increase these specifications.				
2. This coupler is suitable for “safe electrical insulation” only within the safety ratings. Compliance with the safety ratings shall be ensured by means of suitable protective circuits.				
3. Devices are immersed in oil during surge characterization.				
4. The characterization charge is discharging charge (pd) caused by partial discharge.				
5. Capacitance and resistance are measured with all pins on high-side and low-side tied together.				

**7.7 Safety-Related Certifications**

VDE	UL	TUV
Certified according to DIN EN IEC 60747-17 (VDE 0884-17):2021-10	Recognized under UL 1577 Component Recognition Program and CSA Component Acceptance Service Notice No. 5A	Certified according to EN 61010-1: 2010+A1
Reinforced insulation Maximum repetitive peak isolation voltage: 1414 V <sub>PK</sub> Maximum transient isolation voltage: 7070 V <sub>PK</sub> Maximum surge isolation voltage: 8000 V <sub>PK</sub>	Single protection 5000 V <sub>RMS</sub>	5000 V <sub>RMS</sub>
Certification Number: 40057278	Certification Number: E511334-20200520	Certification Number: CN23RC4J 001

**7.8 Electrical Characteristics**

All minimum/maximum specs are at  $T_A = -40^{\circ}\text{C}$  to  $125^{\circ}\text{C}$ ,  $AVDD = 4.5\text{ V}$  to  $5.5\text{ V}$ ,  $DVDD = 3.0\text{ V}$  to  $5.5\text{ V}$ ,  $AINP = -250\text{ mV}$  to  $250\text{ mV}$ ,  $AINN = AGND = 0\text{V}$ , and sinc<sup>3</sup> filter output configured to 16 bits with  $OSR = 256$  (unless otherwise noted). All typical values are at  $25^{\circ}\text{C}$  with  $CLKIN = 20\text{ MHz}$ ,  $AVDD = 5\text{ V}$ , and  $DVDD = 3.3\text{ V}$  (unless otherwise noted).

PARAMETER		TEST CONDITIONS	MIN	TYP	MAX	UNIT
<b>ANALOG INPUT</b>						
$V_{Clipping}$	Maximum input voltage before clipping output	$AINP - AINN$		$\pm 320$		mV
$V_{FSR}$	Specified linear full-scale input range	$AINP - AINN$	-250		250	mV
$V_{CM}$	Operating common-mode input voltage	$(AINP + AINN) / 2$ to AGND	-0.16		$AVDD - 2.1$	V
$V_{CMOV}$	Common-mode overvoltage threshold	$(AINP + AINN) / 2$ to AGND	$AVDD - 2$			V
$V_{CMOV\_HYS}$	Hysteresis of common-mode over-voltage threshold			100		mV
$C_{IN}$	Single-ended input capacitance	$f_{IN} = 270\text{ kHz}$ , $AINN = AGND$		2		pF
$C_{IND}$	Differential input capacitance	$f_{IN} = 270\text{ kHz}$		1		pF
$R_{IN}$	Single-ended input resistance	$AINN = AGND$		19		k $\Omega$
$R_{IND}$	Differential input resistance			22		k $\Omega$
$I_{IN}$	Input current	$AINP = AINN = AGND$ , $I_{IN} = (I_{INP} + I_{INN}) / 2$	-41	-30	-24	$\mu\text{A}$
$TC_{I_{IN}}$	Input current drift			$\pm 1$		nA/ $^{\circ}\text{C}$
$I_{INOS}$	Input offset current	$I_{INOS} = I_{INP} - I_{INN}$		$\pm 5$		nA
$CMRR_{IN}$	Input common-mode rejection ratio	DC, $AINP = AINN$		-85		dB
		$f_{IN} = 10\text{ kHz}$ , $AINP = AINN$		-85		
PSRR	Power supply rejection ratio	At $AVDD$ , DC, $AINP = AINN = AGND$		-98		dB
		At $AVDD$ , 100mV and 10kHz ripple, $AINP = AINN = AGND$		-98		
$BW_{IN}$	-3 dB input bandwidth <sup>1</sup>			1000		kHz
CMTI	Common-mode transient immunity	$ AGND - DGND  = 1.5\text{ kV}$	100	150		kV/ $\mu\text{s}$
<b>MODULATOR ACCURACY</b>						
DNL	Differential nonlinearity	Resolution: 16 bits	-0.99		0.99	LSB
INL	Integral nonlinearity <sup>2</sup>	Resolution: 16 bits	-8	$\pm 2$	8	LSB
$E_O$	Offset error	Initial, at $T_A = 25^{\circ}\text{C}$ , $AINP = AINN = AGND$	-1	$\pm 0.1$	1	mV
$TCE_O$	Offset drift		-3.5	$\pm 1$	3.5	$\mu\text{V}/^{\circ}\text{C}$
$E_G$	Gain error	Initial, at $T_A = 25^{\circ}\text{C}$	-2%	$\pm 0.1\%$	2%	
$TCE_G$	Gain drift			$\pm 25$		ppm/ $^{\circ}\text{C}$
SNR	Signal-to-noise ratio	$f_{IN} = 1\text{ kHz}$ , $BW = 10\text{ kHz}$		85		dB
SINAD	Signal-to-noise-and-distortion ratio	$f_{IN} = 1\text{ kHz}$ , $BW = 10\text{ kHz}$		84		dB
THD	Total harmonic distortion	$f_{IN} = 1\text{ kHz}$ , $BW = 10\text{ kHz}$		-91		dB
SFDR	Spurious-free dynamic range	$f_{IN} = 1\text{ kHz}$ , $BW = 10\text{ kHz}$		94		dB
<b>Note:</b>						
1. Design guarantee.						
2. The INL is defined as the maximum deviation from a straight line passing through the end-point of the ideal ADC transfer function once the gain and offset errors have been nullified and expressed as number of LSBs over the specified linear full-scale input range.						



**Electrical Characteristics (Continued)**

All minimum/maximum specs are at  $T_A = -40^{\circ}\text{C}$  to  $125^{\circ}\text{C}$ ,  $AVDD = 4.5\text{ V}$  to  $5.5\text{ V}$ ,  $DVDD = 3.0\text{ V}$  to  $5.5\text{ V}$ ,  $A\text{INP} = -250\text{ mV}$  to  $250\text{ mV}$ ,  $A\text{INN} = \text{AGND} = 0\text{V}$ , and sinc<sup>3</sup> filter output configured to 16 bits with  $\text{OSR} = 256$  (unless otherwise noted). All typical values are at  $25^{\circ}\text{C}$  with  $\text{CLKIN} = 20\text{ MHz}$ ,  $AVDD = 5\text{ V}$ , and  $DVDD = 3.3\text{ V}$  (unless otherwise noted).

PARAMETER		TEST CONDITIONS	MIN	TYP	MAX	UNIT
<b>DIGITAL INPUT</b>						
$I_{\text{IN}}$	Input current	$2.7\text{ V} \leq V_{\text{IN}} \leq 5.5\text{ V}$	0		7	$\mu\text{A}$
$C_{\text{IN}}$	Input capacitance			4		pF
$V_{\text{IH}}$	Logic high-level input voltage		$0.7 \times DVDD$		$DVDD + 0.3$	V
$V_{\text{IL}}$	Logic low-level input voltage		-0.3		$0.3 \times DVDD$	V
<b>DIGITAL OUTPUT</b>						
$C_{\text{L}}$	Output load capacitance			30		pF
$V_{\text{OH}}$	Logic high-level output voltage	$I_{\text{OH}} = -20\ \mu\text{A}$	$DVDD - 0.1$			V
		$I_{\text{OH}} = -4\ \text{mA}$	$DVDD - 0.4$			
$V_{\text{OL}}$	Logic low-level output voltage	$I_{\text{OL}} = 20\ \mu\text{A}$			0.1	V
		$I_{\text{OL}} = 4\ \text{mA}$			0.4	
<b>POWER SUPPLY</b>						
$AVDD_{\text{UV}}$	AVDD undervoltage threshold	AVDD rising		2.5	2.7	V
$I_{\text{AVDD}}$	High-side supply current	$4.5\text{ V} \leq AVDD \leq 5.5\text{ V}$		10.9	15.5	mA
$I_{\text{DVDD}}$	Low-side supply current with $C_{\text{L}} = 15\ \text{pF}^1$	$3.0\text{ V} \leq DVDD \leq 3.6\text{ V}$		3.3	5.3	mA
		$4.5\text{ V} \leq DVDD \leq 5.5\text{ V}$		4.0	7.0	
<b>Note:</b>						
1. $C_{\text{L}}$ is approximately 15pF including external (probe and stray) capacitance.						

**7.9 Switching Characteristics**

All minimum/maximum specs are at  $T_A = -40^{\circ}\text{C}$  to  $125^{\circ}\text{C}$ ,  $AVDD = 4.5\text{ V}$  to  $5.5\text{ V}$ ,  $DVDD = 3.0\text{ V}$  to  $5.5\text{ V}$ ,  $A\text{INP} = -250\text{ mV}$  to  $250\text{ mV}$ ,  $A\text{INN} = \text{AGND} = 0\text{V}$ , and sinc<sup>3</sup> filter output configured to 16 bits with  $\text{OSR} = 256$  (unless otherwise noted). All typical values are at  $25^{\circ}\text{C}$  with  $\text{CLKIN} = 20\text{ MHz}$ ,  $AVDD = 5\text{ V}$ , and  $DVDD = 3.3\text{ V}$  (unless otherwise noted).

PARAMETER	TEST CONDITIONS	MIN	TYP	MAX	UNIT		
$f_{\text{CLKIN}}$	CLKIN clock frequency	$4.5\text{ V} \leq AVDD \leq 5.5\text{ V}$		5	21	MHz	
Duty Cycle	CLKIN clock duty cycle	$t_{\text{HIGH}} / t_{\text{CLKIN}}, 4.5\text{ V} \leq AVDD \leq 5.5\text{ V}$		42.5%	50%	57.5%	
$t_{\text{h}}$	Hold time of DOUT after rising edge of CLKIN <sup>1</sup>	$C_L = 15\text{ pF}^1$ ; <i>See Figure</i>		3.5		ns	
$t_{\text{d}}$	Delay time of DOUT after rising edge of CLKIN <sup>1</sup>	$C_L = 15\text{ pF}^1$ ; <i>See Figure</i>			16	ns	
$t_{\text{r}}$	Rise time of DOUT (10%–90%)	$C_L = 15\text{ pF}^1$			1.8	5.0	ns
$t_{\text{f}}$	Fall time of DOUT (90%–10%)	$C_L = 15\text{ pF}^1$			1.8	5.0	ns
$t_{\text{astart}}$	Analog startup time	AVDD step to $4.5\text{ V}$ with $3.0\text{ V} \leq DVDD$ ; <i>See Figure</i>			500	$\mu\text{s}$	

**Note:**

- $C_L$  is approximately 15pF including external (probe and stray) capacitance.

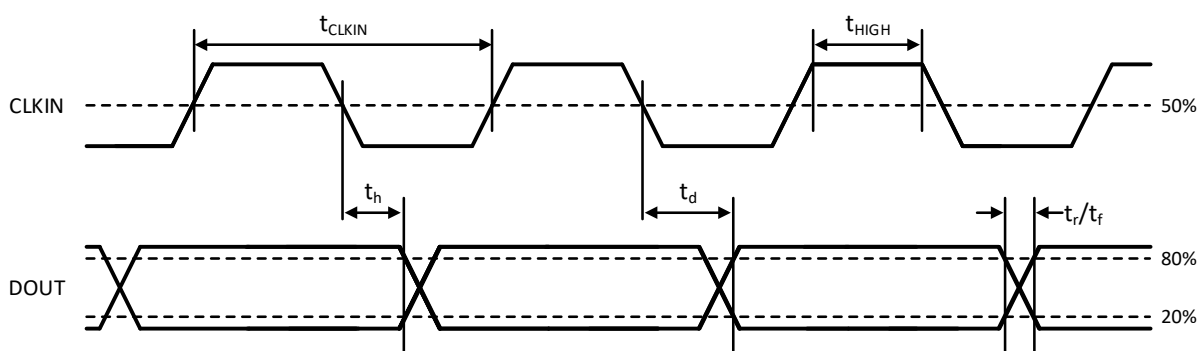
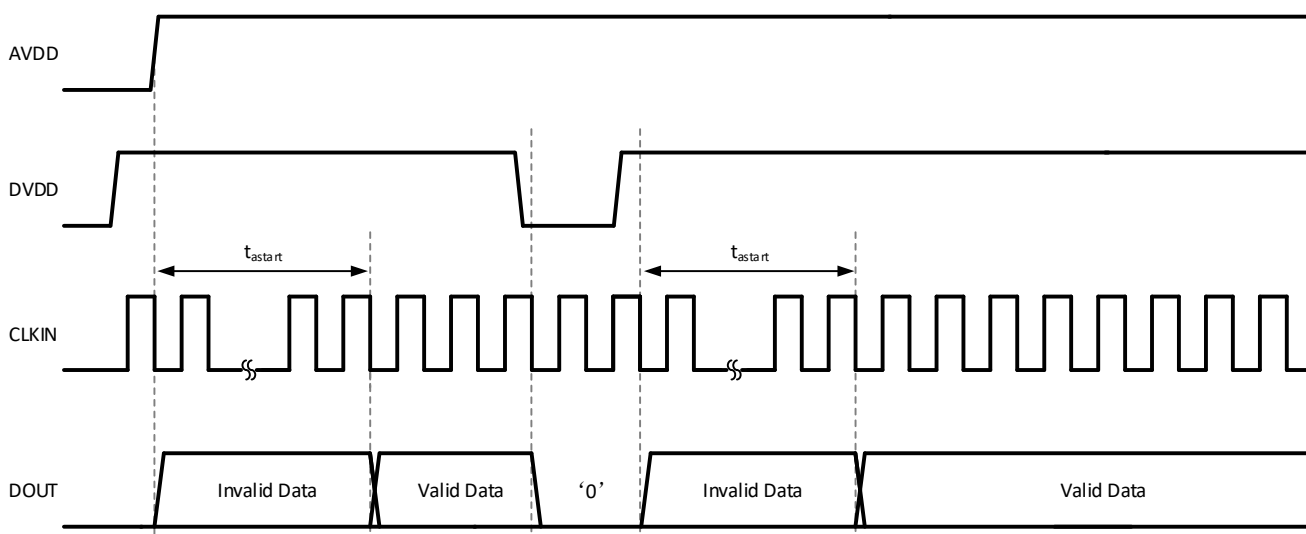
**Figure 7-1. CA-IS1204 Digital Output Timing**

**Figure 7-2. CA-IS1204 Startup Timing**

### 7.10 Typical Characteristics and Waveforms

All minimum/maximum specs are at  $T_A = -40^{\circ}\text{C}$  to  $125^{\circ}\text{C}$ ,  $AVDD = 4.5\text{ V}$  to  $5.5\text{ V}$ ,  $DVDD = 3.0\text{ V}$  to  $5.5\text{ V}$ ,  $AINP = -250\text{ mV}$  to  $250\text{ mV}$ ,  $AINN = AGND = 0\text{V}$ , and sinc<sup>3</sup> filter output configured to 16 bits with  $OSR = 256$  (unless otherwise noted). All typical values are at  $25^{\circ}\text{C}$  with  $CLKIN = 20\text{ MHz}$ ,  $AVDD = 5\text{ V}$ , and  $DVDD = 3.3\text{ V}$  (unless otherwise noted).

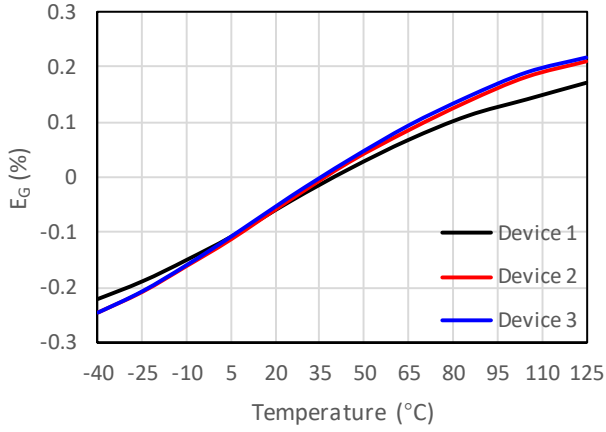

Figure 7-3. Gain Error vs. Temperature

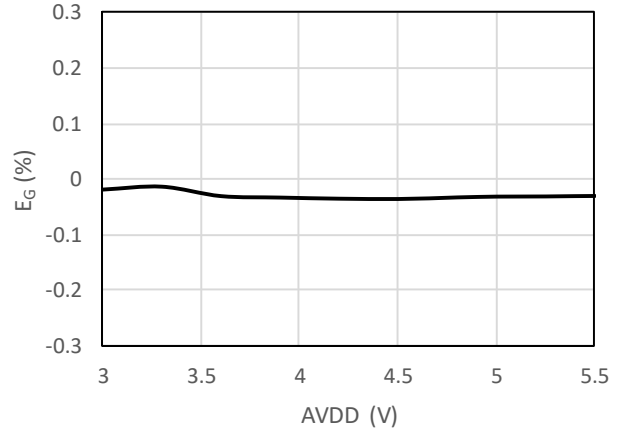

Figure 7-4. Gain Error vs. High-side Supply Voltage

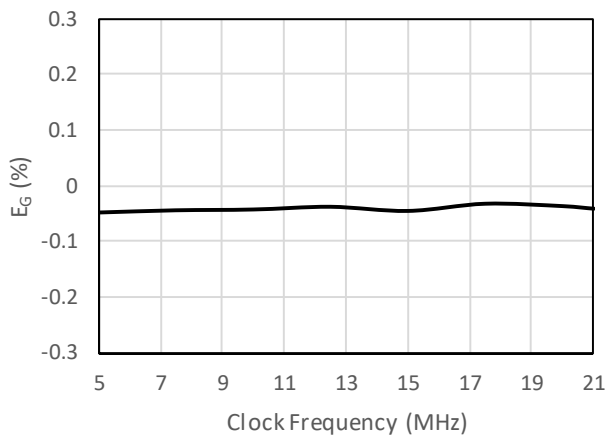

Figure 7-5. Gain Error vs. Clock Frequency

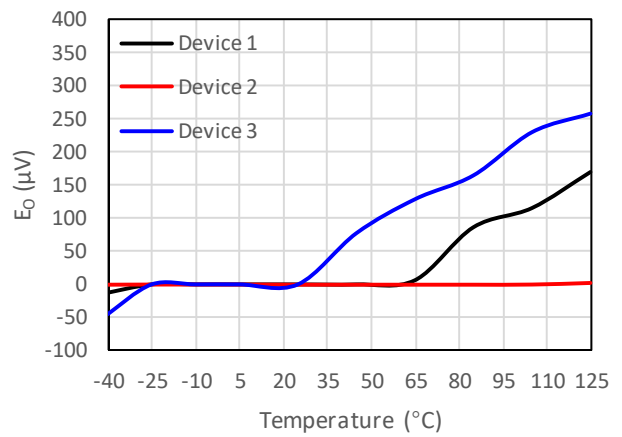

Figure 7-6. Offset Error vs. Temperature

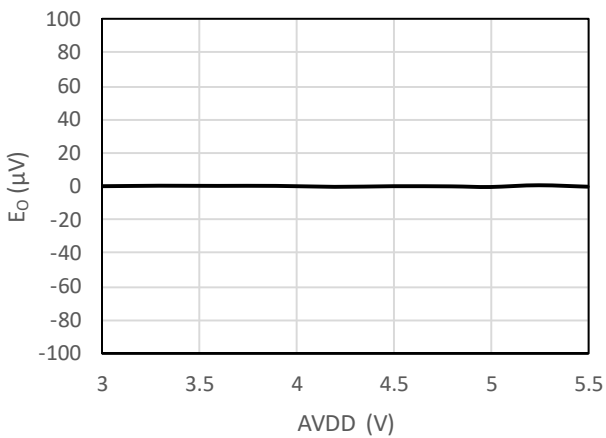

Figure 7-7. Offset Error vs. High-side Supply Voltage

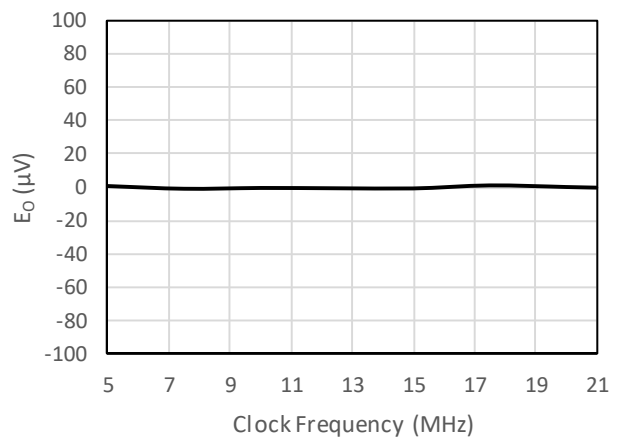

Figure 7-8. Offset Error vs. Clock Frequency

Typical Characteristics and Waveforms (Continued)

All minimum/maximum specs are tested over recommended operating conditions and sinc<sup>3</sup> filter output configured to 16 bits with OSR = 256 (unless otherwise noted). All typical values are at 25°C with CLKIN = 20 MHz, AVDD = 5 V, and DVDD = 3.3 V (unless otherwise noted).

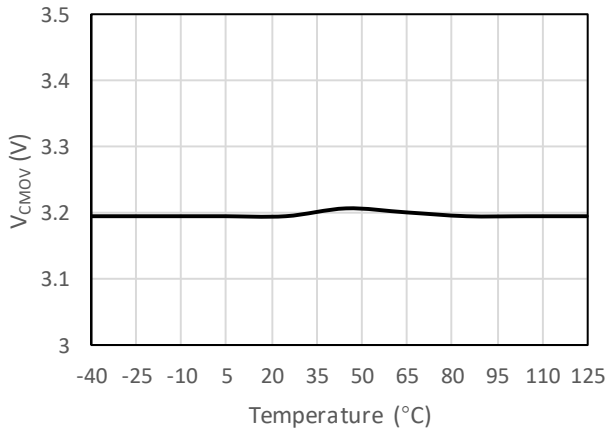

Figure 7-9. High-Side  $V_{CMOV}$  vs. Temperature

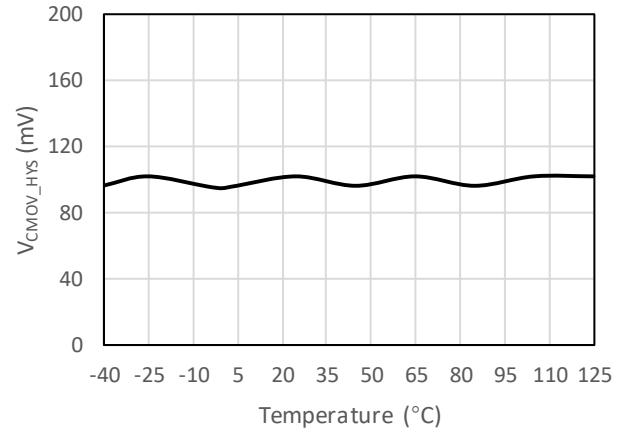

Figure 7-10. High-Side  $V_{CMOV\_HYS}$  vs. Temperature

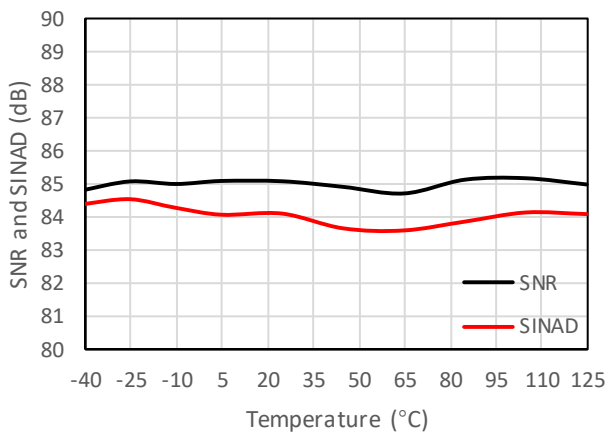

Figure 7-11. SNR and SINAD vs. Temperature

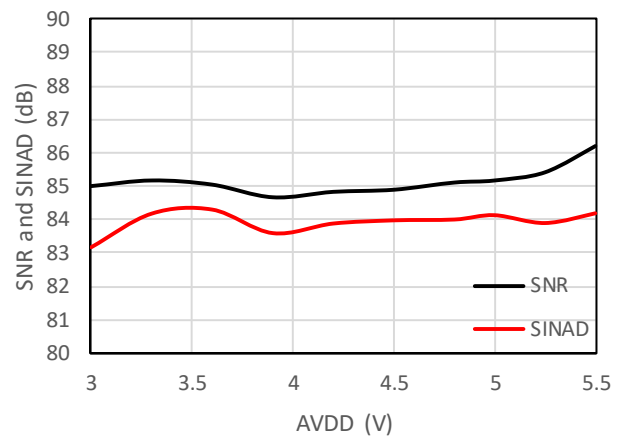

Figure 7-12. SNR and SINAD vs. High-side Supply Voltage

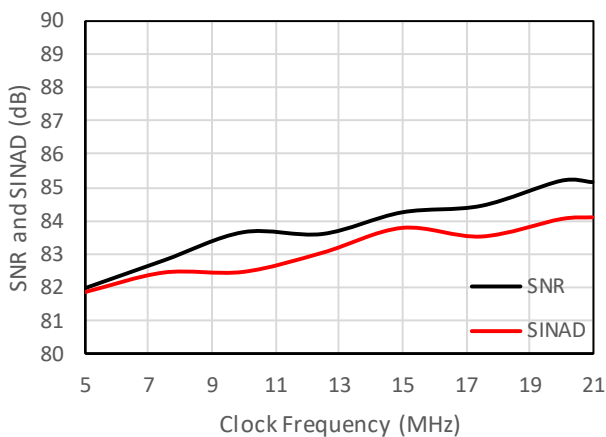

Figure 7-13. SNR and SINAD vs. Clock Frequency

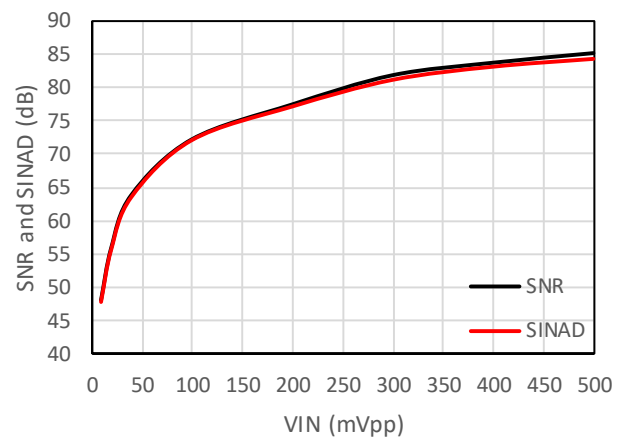

Figure 7-14. SNR and SINAD vs. VIN

### Typical Characteristics and Waveforms (Continued)

All minimum/maximum specs are tested over recommended operating conditions and sinc<sup>3</sup> filter output configured to 16 bits with OSR = 256 (unless otherwise noted). All typical values are at 25°C with CLKIN = 20 MHz, AVDD = 5 V, and DVDD = 3.3 V (unless otherwise noted).

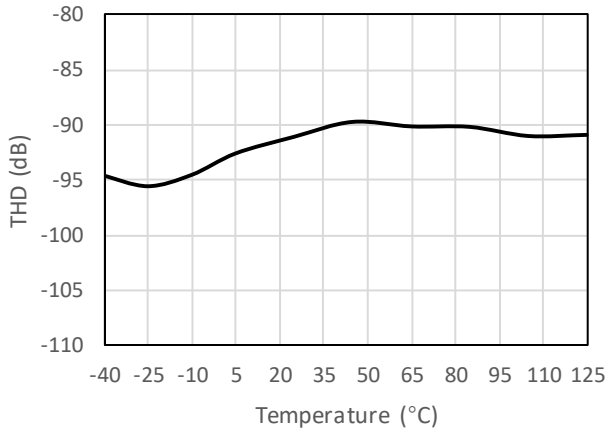

Figure 7-15. THD vs. Temperature

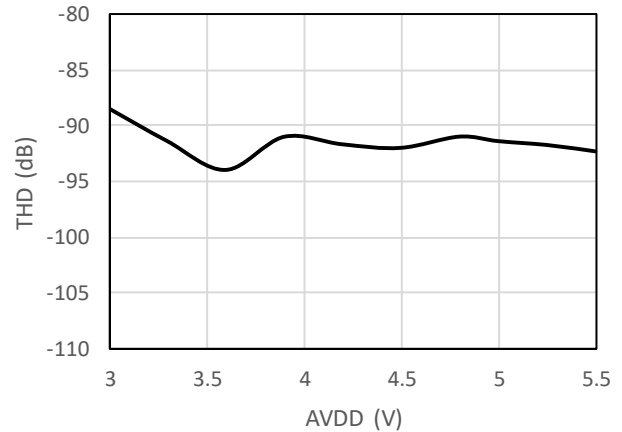

Figure 7-16. THD vs. High-side Supply Voltage

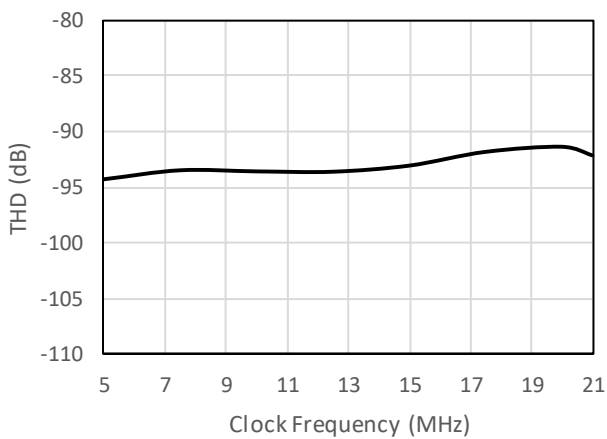

Figure 7-17. THD vs. Clock Frequency

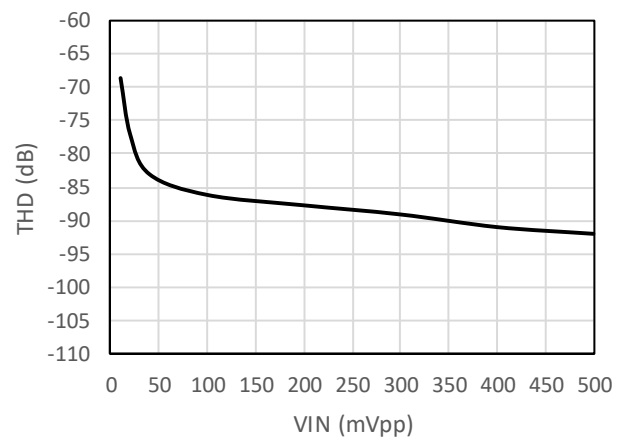

Figure 7-18. THD vs. VIN

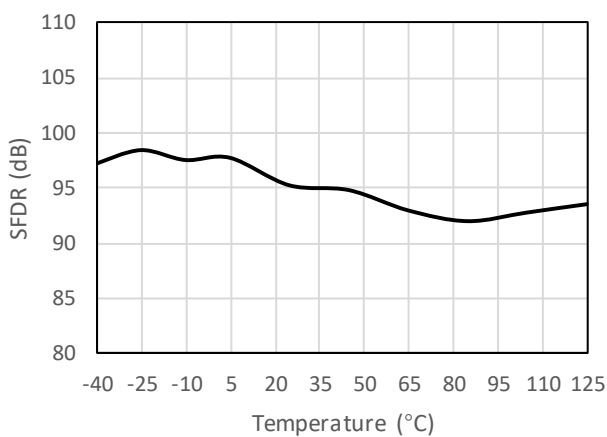

Figure 7-19. SFDR vs. Temperature

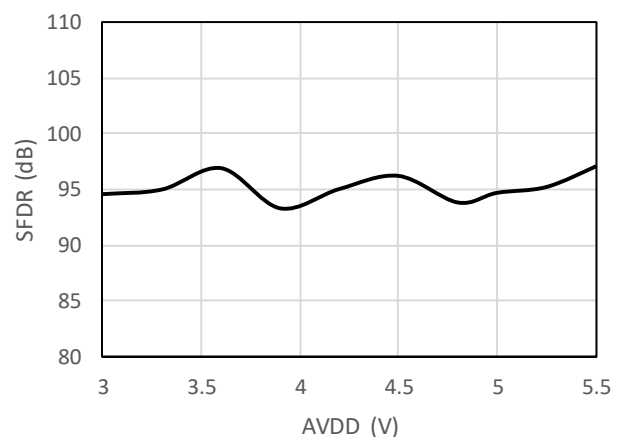

Figure 7-20. SFDR vs. High-side Supply Voltage

**Typical Characteristics and Waveforms (Continued)**

All minimum/maximum specs are tested over recommended operating conditions and sinc<sup>3</sup> filter output configured to 16 bits with OSR = 256 (unless otherwise noted). All typical values are at 25°C with CLKIN = 20 MHz, AVDD = 5 V, and DVDD = 3.3 V (unless otherwise noted).

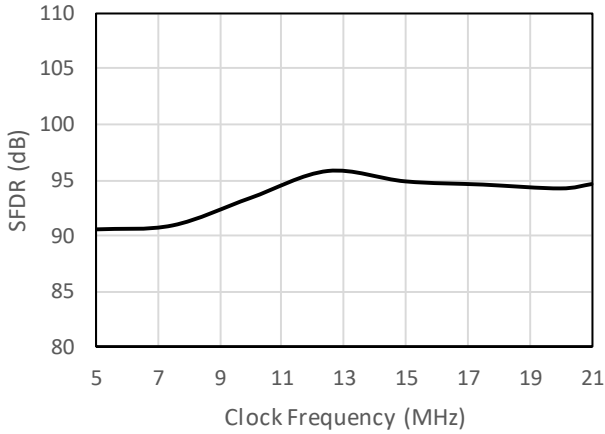

Figure 7-21. SFDR vs. Clock Frequency

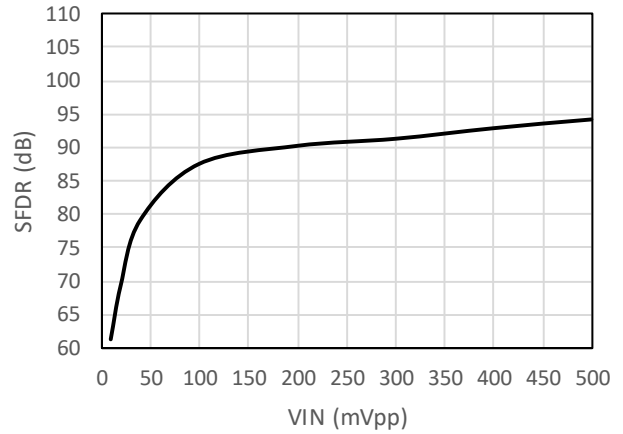

Figure 7-22. SFDR vs. VIN

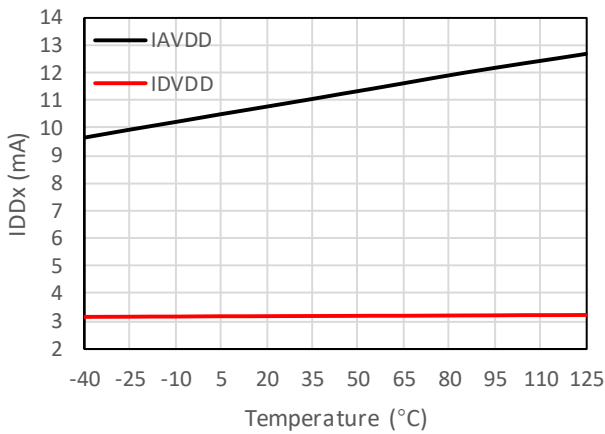

Figure 7-23. Supply Current vs. Temperature

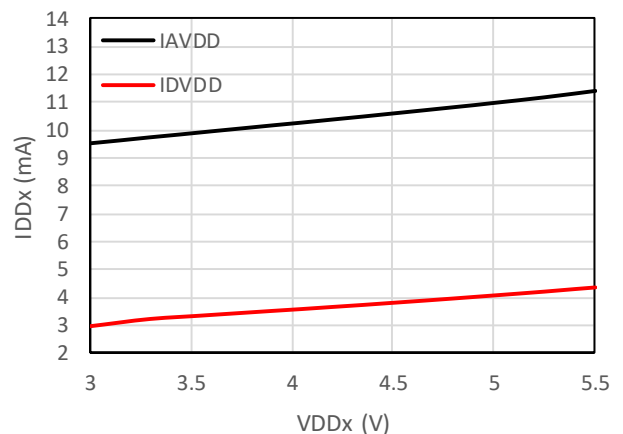

Figure 7-24. Supply Current vs. Supply Voltage

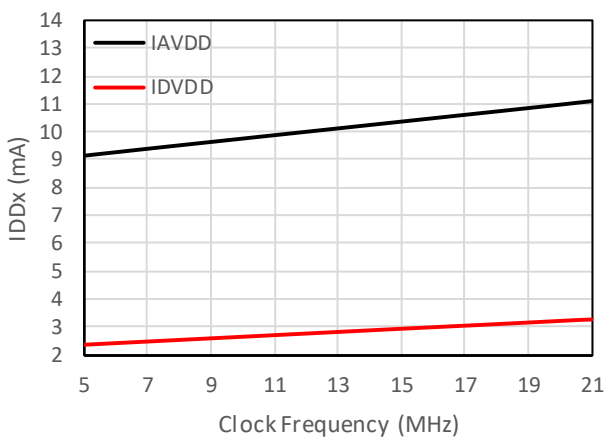

Figure 7-25. Supply Current vs. Clock Frequency

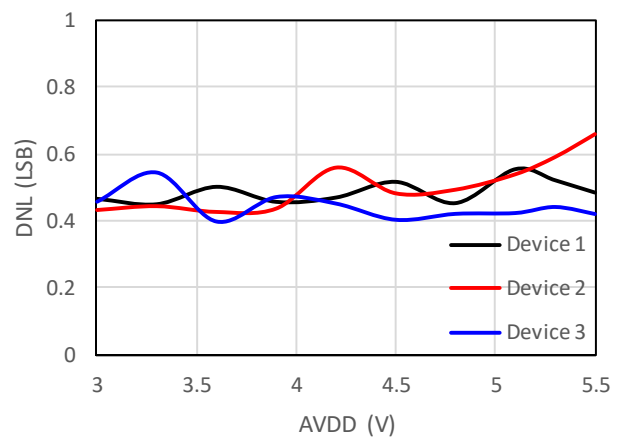

Figure 7-26. DNL vs. High-side Supply Voltage

### Typical Characteristics and Waveforms (Continued)

All minimum/maximum specs are tested over recommended operating conditions and sinc<sup>3</sup> filter output configured to 16 bits with OSR = 256 (unless otherwise noted). All typical values are at 25°C with CLKIN = 20 MHz, AVDD = 5 V, and DVDD = 3.3 V (unless otherwise noted).

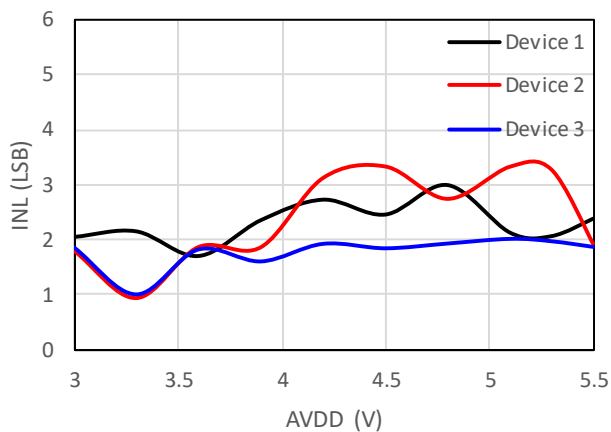

Figure 7-1 INL vs AVDD

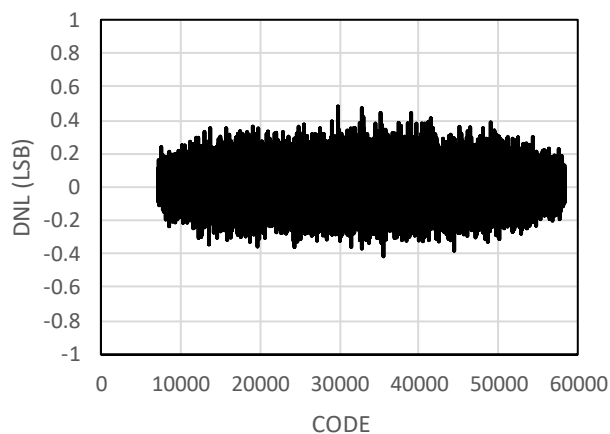

Figure 7-2 Typical DNL

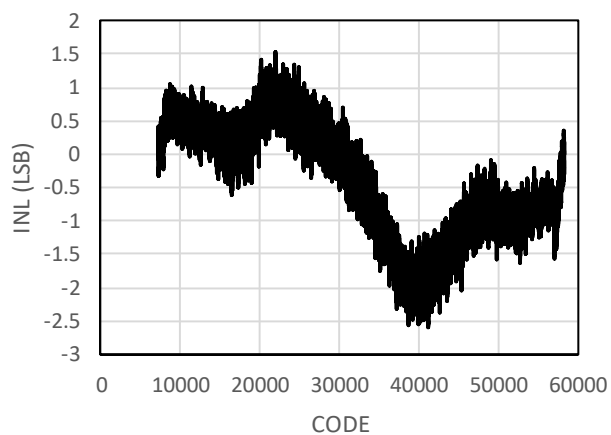

Figure 7-3 Typical INL

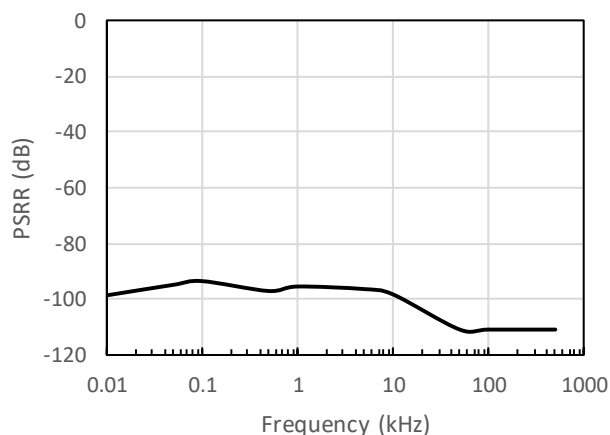

Figure 7-30 PSRR vs frequency

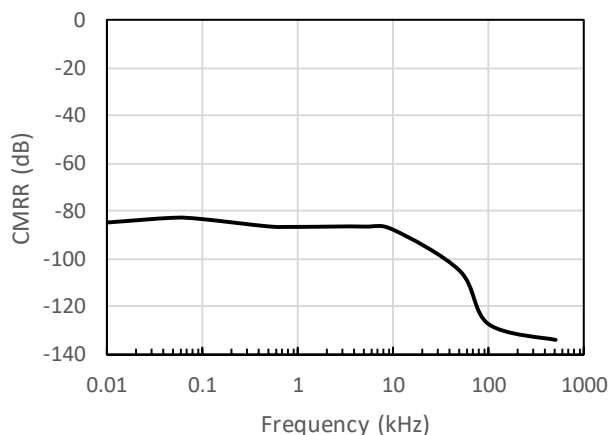

Figure 7-31 CMRR vs frequency

## 8 Detailed Description

### 8.1 Overview

The CA-IS1204 precision isolated sigma-delta ( $\Sigma$ - $\Delta$ ) modulator optimized for shunt resistor-based current sensing and small signal measurement applications. The functional block diagram is shown in Figure. This device performs fully differential analog input to digital output conversion using a single-bit, second-order, switched-capacitor modulator. A single comparator within the modulator quantizes the input signal at a much higher sample rate than the bandwidth of the signal to be measured. The quantizer then presents a stream of 1s and 0s to the digital isolator driver and the driver transmit the bit stream across a SiO<sub>2</sub>-based capacitive isolation barrier to provide up to 5kV<sub>RMS</sub> isolation rating. The modulator is fully differential for maximum signal-to-noise ratio and minimum susceptibility to power-supply noise. On the digital output-side (low-side), the receiver demodulates the signal after advanced signal conditioning and produces the output at DOUT. The density of 1s in the DOUT bit stream output is proportional to the analog input voltage.

To synchronize the entire system operation, the device provides an external clock input CLKIN on the low-side and feeds the clock back to the high-side through digital isolation for the synchronous sigma-delta modulator operating. The input clock frequency range is from 5MHz to 21MHz, much higher than the analog input bandwidth.

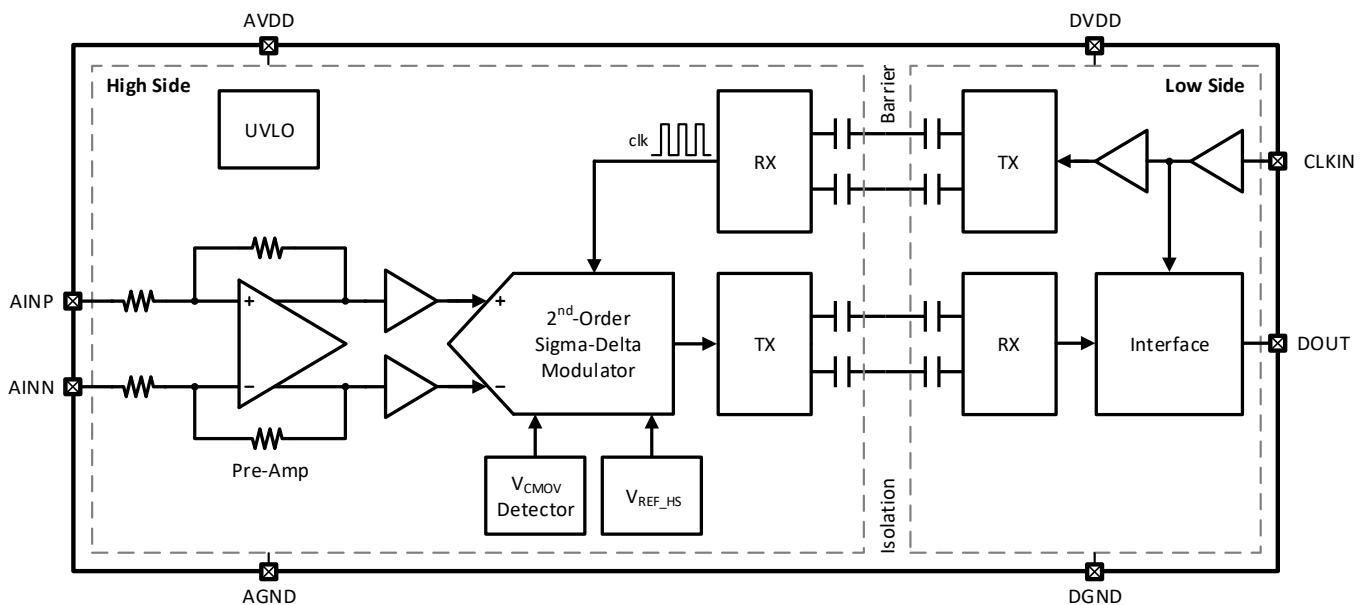

Figure 8-1. Functional Block Diagram of the CA-IS1204

### 8.2 Analog Input (High-side)

The analog input of CA-IS1204 utilizes a full differential preamplifier to amplify the voltage of current sense resistor  $R_{shunt}$ . The gain of the input amplifier is fixed and set by internal precision resistors. The internal fixed gain of CA-IS1204W is 4x, and the corresponding full-scale input voltage range is  $\pm 250\text{mV}$ , the differential input impedance is  $22\text{k}\Omega$  (see the [Electrical Characteristics](#) for more details). Considering of the lower input impedance of CA-IS1204, large gain and offset errors could be introduced when used with high-impedance signal resources. It is very important to select a reasonable current sense resistor and carefully PCB layout.

The internal ESD protection of CA-IS1204 can withstand (AGND-6V) to (AVDD+0.5V) absolute maximum analog input. To guarantee the long-term reliability and device performance, the differential analog input voltage and the input common-mode voltage of the CA-IS1204 should be limited within the specific range.



**8.3 Signal Isolation**

The CA-IS1204 device utilizes Chipanalog’s full differential capacitive isolation technology, as shown in Figure , that contains an ON-OFF keying (OOK) modulation scheme to transfer digital signals across the SiO<sub>2</sub> based isolation barrier between circuits with different power domains. The transmitter sends a high frequency carrier across the barrier to represent one digital state and sends no signal to represent the other digital state. The isolation receiver demodulates the signal and recovery input signal at output through a buffer stage, see Figure for more details. With this OOK architecture, the CA-IS1204 device builds a robust data transmission path between different power domains and support up to 5kV<sub>RMS</sub> galvanic isolation between the analog input side and digital output side.

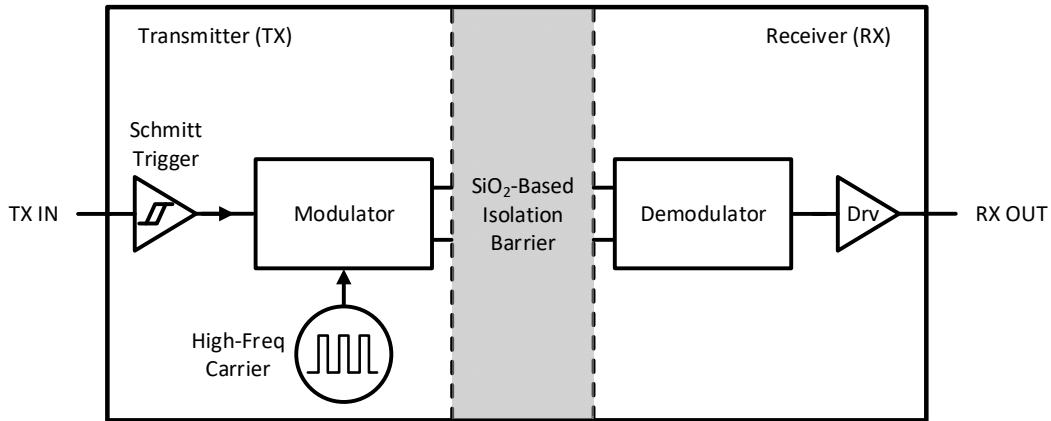

**Figure 8-2. Block Diagram of the Isolation Channel**

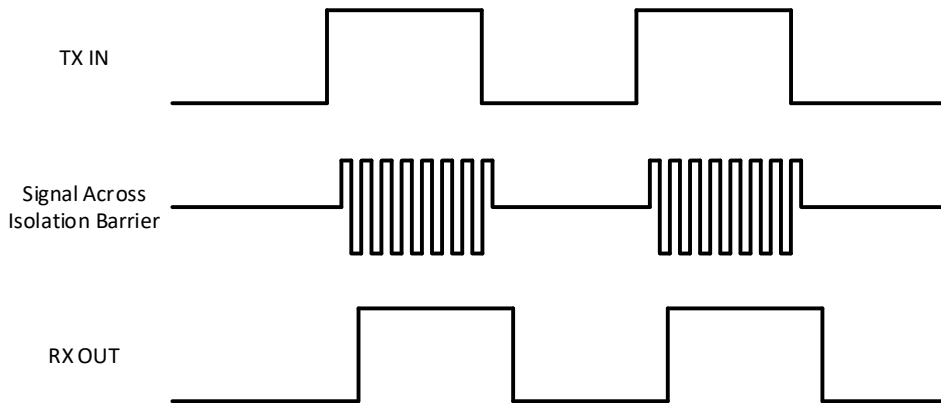

**Figure 8-3. OOK Modulation**

**8.4 Digital Output (Low-side)**

**8.4.1 Bit stream output**

The CA-IS1204 device performs fully differential analog input to digital output conversion using a sigma-delta modulator. The sigma-delta modulator converts the input signal into a digital pulse train whose average duty cycle represents the digitized signal information. Figure shows the relationship between the bit stream output vs. analog input (AINP – AINN). The analog input of 0 V ideally produces to a digital bit-stream of “1” and “0” with high 50% of the time. For the analog input voltage within full-scale input range (±320 mV), the digital output maintains a linear relationship with the analog input, and the density of 1s in the digital output bit-stream can be calculated as following equation:

$$Density|_{1s} = (V_{IN} + V_{Clipping}) / (2 \times V_{Clipping}) \tag{Equation 1}$$

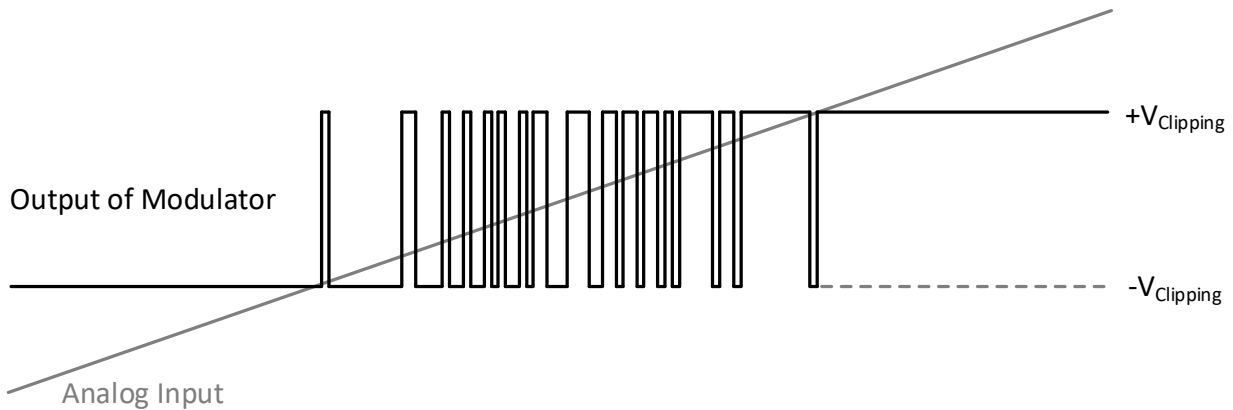

Figure 8-4. CA-IS1204 Modulator Output vs. Analog Input (AINP – AINN)

### 8.4.2 Over-range Output

The maximum input voltage of the CA-IS1204 (before clipping output) is  $\pm 320\text{mV}$ . For the analog input less than or equal to  $-320\text{mV}$ , the CA-IS1204 modulator will clip the bit-stream at “0”, and generate a single “1” every 128 clocks; For the analog input greater than or equal to  $+320\text{mV}$ , the CA-IS1204 modulator will clip the bit-stream at “1”, and generate a single “0” every 128 clocks, see Figure 8-5.

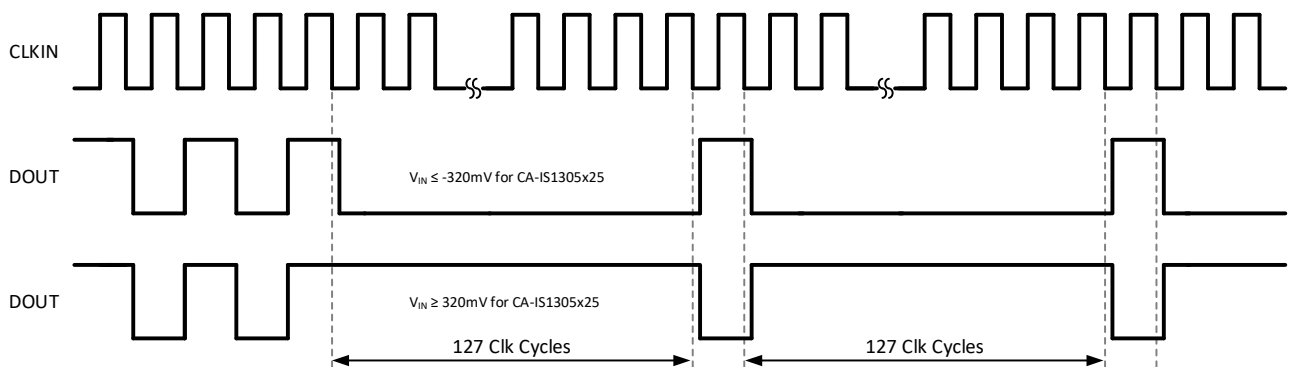

Figure 8-5. CA-IS1204 Over-range Output Waveforms

### 8.4.3 Fail-Safe Output

The CA-IS1204 device features fail-safe output indication which means the devices guarantee a logic-low on the digital output (DOUT) when the high-side power supply (AVDD) is off or loss, or a logic-high at DOUT when the common-mode input voltage  $V_{CM}$  exceeds the common-mode overvoltage threshold  $V_{CMOV}$ . When both cases occur at the same time, the priority of high side supply voltage (AVDD) loss is higher, so DOUT output will remain logic 0, see Figure 8-6 for more details. In the case of a missing high-side supply voltage AVDD, the output of  $\Sigma$ - $\Delta$  modulator is not defined and can cause a system fault or indeterminacy. So the fail-safe output is very useful to provide a fault indication for system and helps to improve system reliability. Also, in this way, differentiating between the AVDD loss and the over range input signal is possible on the system level.

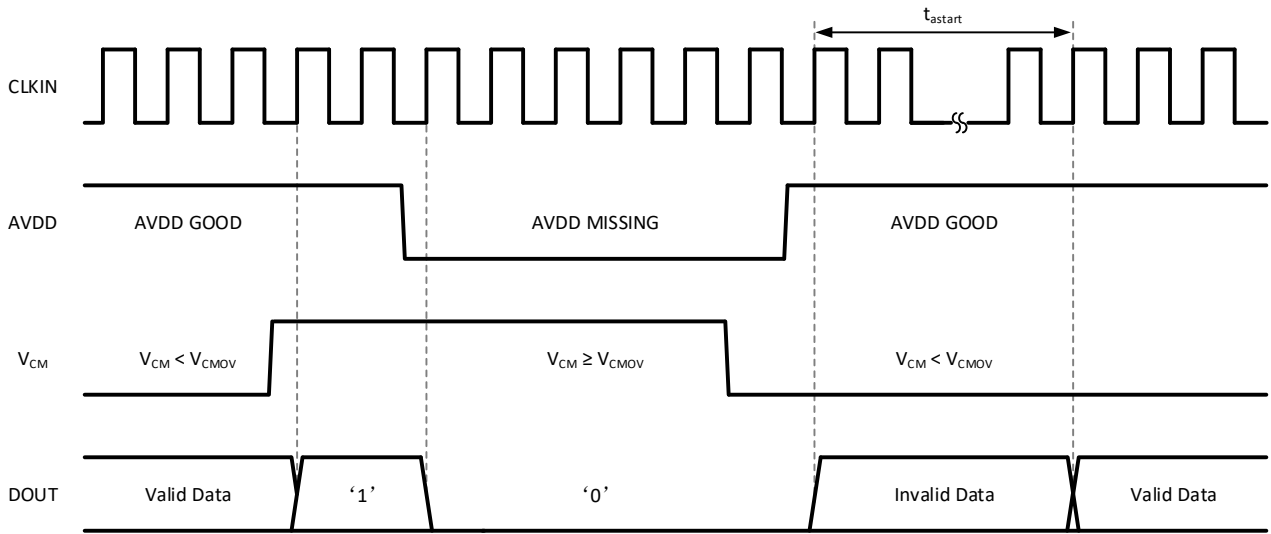

Figure 8-6. CA-IS1204 Fail-Safe Output

**9 Application Information**

**9.1 Typical Application for Current Sense**

**9.1.1 Typical Application Circuit**

The CA-IS1204 precision isolated sigma-delta ( $\Sigma$ - $\Delta$ ) modulator is optimized for shunt resistor-based current sensing applications. A typical current sense application circuit is shown in Figure, the CA-IS1204 device is used to amplify the voltage across the shunt resistor ( $R_{shunt}$ ) with fixed gain (4x), and the internal sigma-delta modulator converts the amplified analog signal into digital bit-stream. The isolated bit stream output is then processed by an external digital decimation filter which can be implemented by FPGA or DSP, resulting in a conversion accuracy up to 16-bits. Robust isolation coupled with up to 150kV/ $\mu$ s typical CMTI enables accurate small signal measurement in noisy environments, making this device ideal for motor drives, photovoltaic inverters, uninterruptible power supplies(UPS) etc. industrial applications. Figure shows the CA-IS1204 in 1-phase motor current sense circuit design.

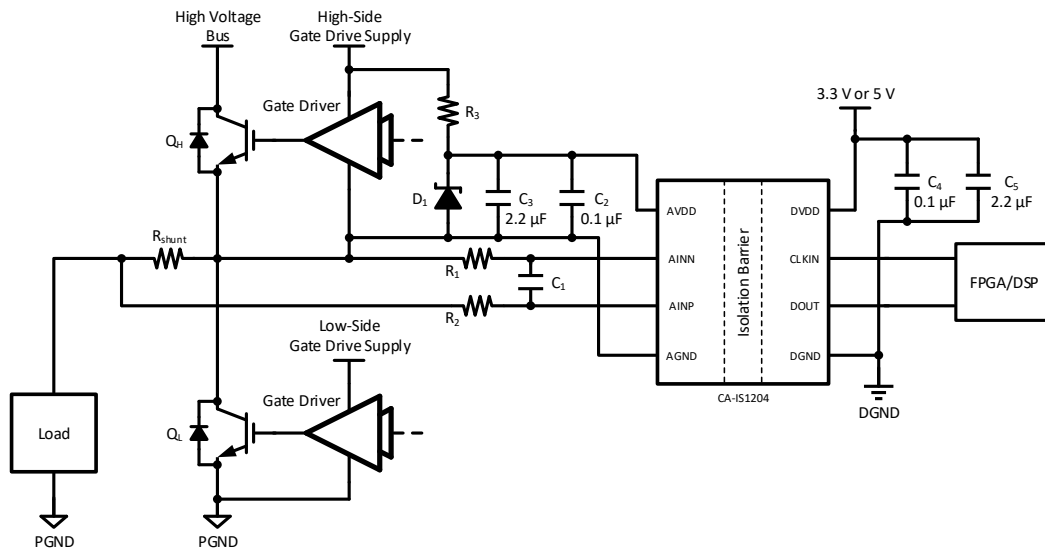

Figure 9-1. Typical Application for 1-phase Current Sensing

### 9.1.2 Choosing Current Sense Resistor

The shunt resistor selection should be a trade off between power dissipation and measurement accuracy. Small value resistors minimize power dissipation, while large value resistors take advantage of the full performance input range of the sigma-delta modulator. Choose the shunt resistor based on the following criteria:

- **Accuracy:**

A high  $R_{shunt}$  value allows lower currents to be measured more accurately. This is because offsets become less significant when the sense voltage is larger. For best performance, select  $R_{shunt}$  to provide approximately  $V_{FSR}$  ( $\pm 250mV$ ) of sense voltage for the nominal full-scale current in each application. And the voltage drop at  $R_{shunt}$  caused by the maximum current should be less than  $V_{Clipping}$  ( $\pm 320mV$ ).

- **Power dissipation**

At high current levels, the  $I^2R$  losses in  $R_{shunt}$  can be significant. Take this into consideration when choosing the resistor value and its power dissipation rating. Also, the sense resistor's value might drift if it is heat up excessively.

Due to the high currents that may flow through  $R_{shunt}$ , take care to eliminate solder and parasitic trace resistance from causing errors in the sense voltage. Either use a four-terminal current sense resistor or use Kelvin (force and sense) PCB layout technique. The Kelvin-sense traces should be as close as possible to the current-sense resistor's solder contact pads. If the Kelvin-sensing contact pads are spaced wider relative to the sense resistor, error will be introduced from the additional trace resistance.

### 9.1.3 Analog Input Filter

To improve signal-to-noise performance of CA-IS1204 signal path, an external 1<sup>st</sup>-order RC filter is recommended in front of the amplifier, as shown in the typical application circuit [Figure](#), selecting  $R_1 = R_2 = 10\Omega$  and  $C_1 = 20nF$ , the input bandwidth of the analog front-end of the device can be limited within 400kHz.

### 9.1.4 Supply Power

The high-side power supply of the CA-IS1204 can generate a 3.3V or 5V voltage from a high-side grid-driven power supply via a Zener diode(D1). It is recommended that a decoupling capacitor(C2) with a low equivalent series resistance of 0.1uf be placed as close as possible to AVDD pin of CA-IS1204. An additional capacitor(C3) is recommended for better filtering of the high-side supply path. The capacitance value can be selected from 2.2uf to 10uf.

Similarly, the 0.1uf decoupling capacitor(C4) and the 2.2uf to 10uf capacitor(C5) should be placed as close as possible to the DVDD pin of CA-IS1204 to filter the bottom power supply path.

### 9.1.5 Digital Output Filter

The CA-IS1204 modulator provides 2<sup>nd</sup>-order frequency shaping of the quantization noise resulting from the single bit quantizer. To remove the frequency shaped quantization noise, a digital decimation filter is required. For the CA-IS1204 2<sup>nd</sup> order modulator circuit design, a sinc<sup>3</sup> filter is recommended because of the low cost hardware design and better performance. A FPGA or DSP can be used to implement this filter to provide the transfer function of a sinc<sup>3</sup> filter as below.

$$H(Z) = \left[ \frac{1}{DR} \frac{(1 - Z^{-DR})}{(1 - Z^{-1})} \right]^3 \quad \text{(Equation 2)}$$

Where DR is the decimation rate, it is the ratio of modulator clock frequency  $f_{CLKIN}$  and throughput rate of the sinc<sup>3</sup> filter  $f_{DATA}$ , which is also called oversampling rate (OSR).

$$DR = OSR = f_{CLKIN}/f_{DATA} \quad (\text{Equation 3})$$

The output data width is shown in below equation.

$$\text{Data Width} = 3 \times \log_2 DR \quad (\text{Equation 4})$$

All of the characterization in section of [Electrical Characteristics](#) is tested with a sinc<sup>3</sup> filter with an oversampling ratio(OSR) of 256 and an output word width of 16 bits.

The characteristics of the sinc<sup>3</sup> filter are summarized in [Table 9-1](#). As the decimation rate increased, the output data width from sinc<sup>3</sup> filter increased as well, while the throughput rate decreased, resulting higher SNR performance. Thus, designers can trade off between data rate and conversion accuracy based on the application requirements.

**Table 9-1. Characteristics of sinc<sup>3</sup> Filter at 20MHz f<sub>CLKIN</sub>**

Decimation Rate (DR)	f <sub>DATA</sub> (kHz)	Output Data Width (Bits)	Filter Response (kHz)
32	625	15	163.7
64	312.5	18	81.8
128	156.2	21	40.9
256	78.1	24	20.4
512	39.1	27	10.2

## 9.2 Voltage Measurement

The CA-IS1204 current sense amplifier, along with a voltage divider, can be used as an isolated voltage measurement solution, see [Figure 9-2](#) typical application circuit. The resistors of R<sub>41</sub>, R<sub>42</sub>, R<sub>51</sub>, R<sub>52</sub>, R<sub>61</sub> and R<sub>62</sub> are the internal resistors of the CA-IS1204 device, where R<sub>41</sub>, R<sub>42</sub>, R<sub>51</sub>, and R<sub>52</sub> are used to setup the amplifier gain, R<sub>41</sub> = R<sub>42</sub> = 12.5 kΩ, R<sub>51</sub> = R<sub>52</sub> = 50 kΩ; R<sub>61</sub> and R<sub>62</sub> are used for the common-mode voltage detector, R<sub>61</sub> = R<sub>62</sub> = 100 kΩ. The voltage-divider (R<sub>21</sub>+R<sub>11</sub> and R<sub>31</sub>) reduces the input voltage from the power supply bus voltage to ±250mV to match the analog input range of CA-IS1204. Thus, for the high-voltage power supply bus, (R<sub>21</sub>+R<sub>11</sub>) >> R<sub>31</sub>.

Also, the bias current I<sub>INP</sub> caused by V<sub>CM</sub> (1.875V, typ.) passing through the voltage sense resistor R<sub>31</sub> will cause significant offset error as well. To reduce the gain error and offset error, select R<sub>31</sub> as small as possible. However, to limit the current consumption of the voltage-divider, choosing large resistance values for R<sub>21</sub>+R<sub>11</sub> and R<sub>31</sub> will minimize overall power consumption. Designers need to balance the choice of divider resistance.

In order to cancel out the offset error introduced by the bias current I<sub>INP</sub> flowing through R<sub>31</sub>, the resistor R<sub>32</sub> can be added at VINN input. As the error compensating resistor, the ideal R<sub>32</sub> should be the parallel resistance of (R<sub>21</sub>+R<sub>11</sub>)/R<sub>31</sub>, see below R<sub>32</sub> calculation equation,

$$R_{32} = \frac{R_{31} \times (R_{21} + R_{11})}{R_{31} + R_{21} + R_{11}} \cong R_{31}, \quad (R_{11} + R_{21} \gg R_{31})$$

Adding R<sub>32</sub> can remove the offset error caused by I<sub>INP</sub>, but there will be an expected difference between the modulator's differential input voltage (A<sub>INP</sub> – A<sub>INN</sub>) and the voltage drop on R<sub>31</sub> given by the resistor divider. This discrepancy can be expressed as a gain error, as shown in below equation,

$$G_{\text{ERROR}} = \frac{R_{31}}{R_{31} + R_{41}}$$

Choosing appropriate R<sub>31</sub> to balance gain error and power consumption, combine with compensating resistor R<sub>32</sub>, the voltage measurement performance shown in [Figure 9-2](#) typical application circuit is acceptable for most applications.

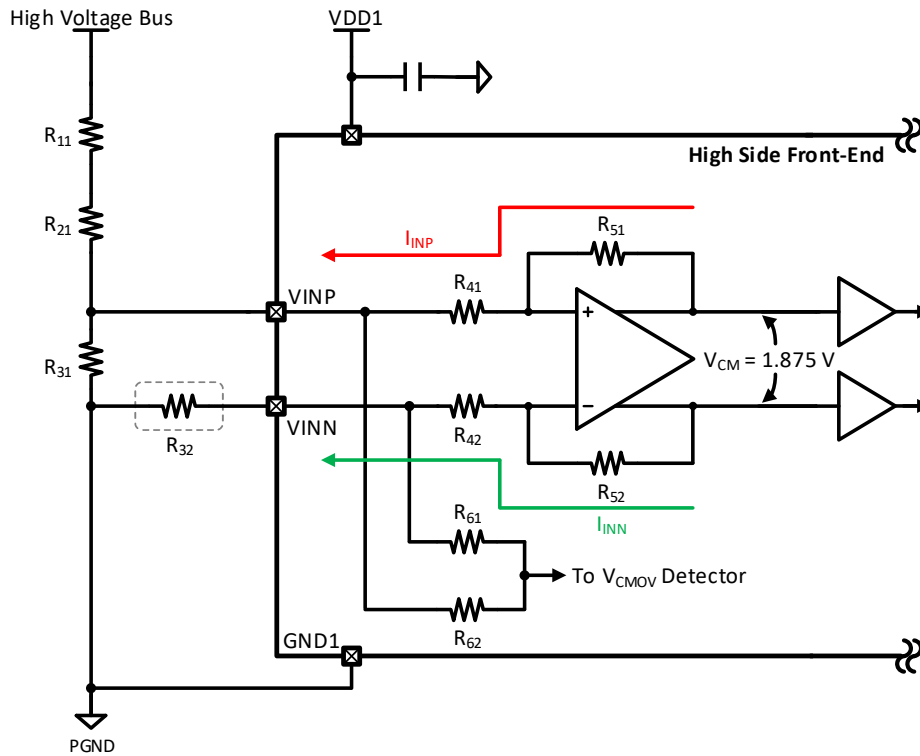

Figure 9-2. Typical Application Circuit for Voltage-Measurement

### 9.3 Announcements

Do not leave the input of CA-IS1204 dangling when using. If both AINP and AINN are dangling, the input common mode will be pull to high voltage by internal bias, which may touch the safety fault mode under some supply voltages, which may lead to abnormal system reaction.

**10 Package Information**

**10.1 16-Pin Wide Body SOIC Package**

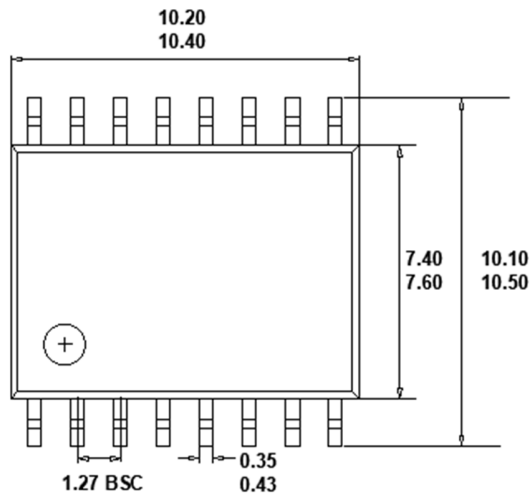

**TOP VIEW**

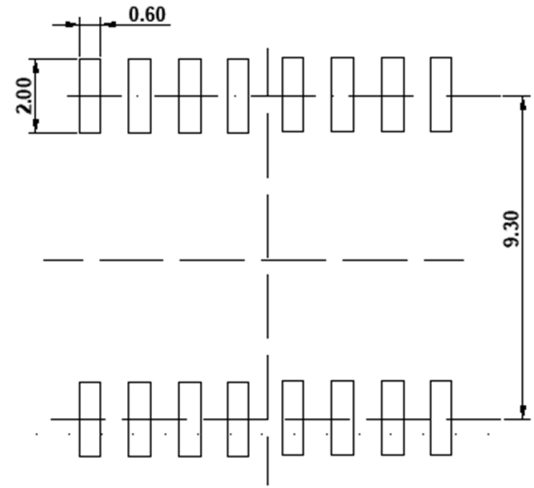

**RECOMMENDED LAND PATTERN**

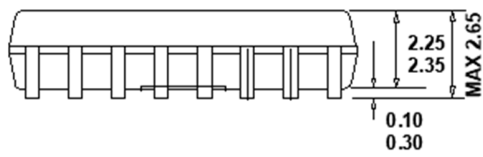

**FRONT VIEW**

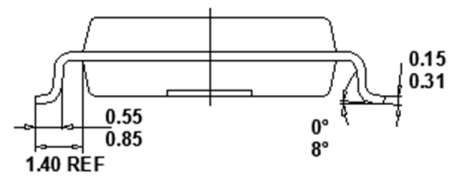

**LEFT SIDE VIEW**

Note: All dimensions are shown in millimeters.

11 Soldering Temperature (reflow) Profile

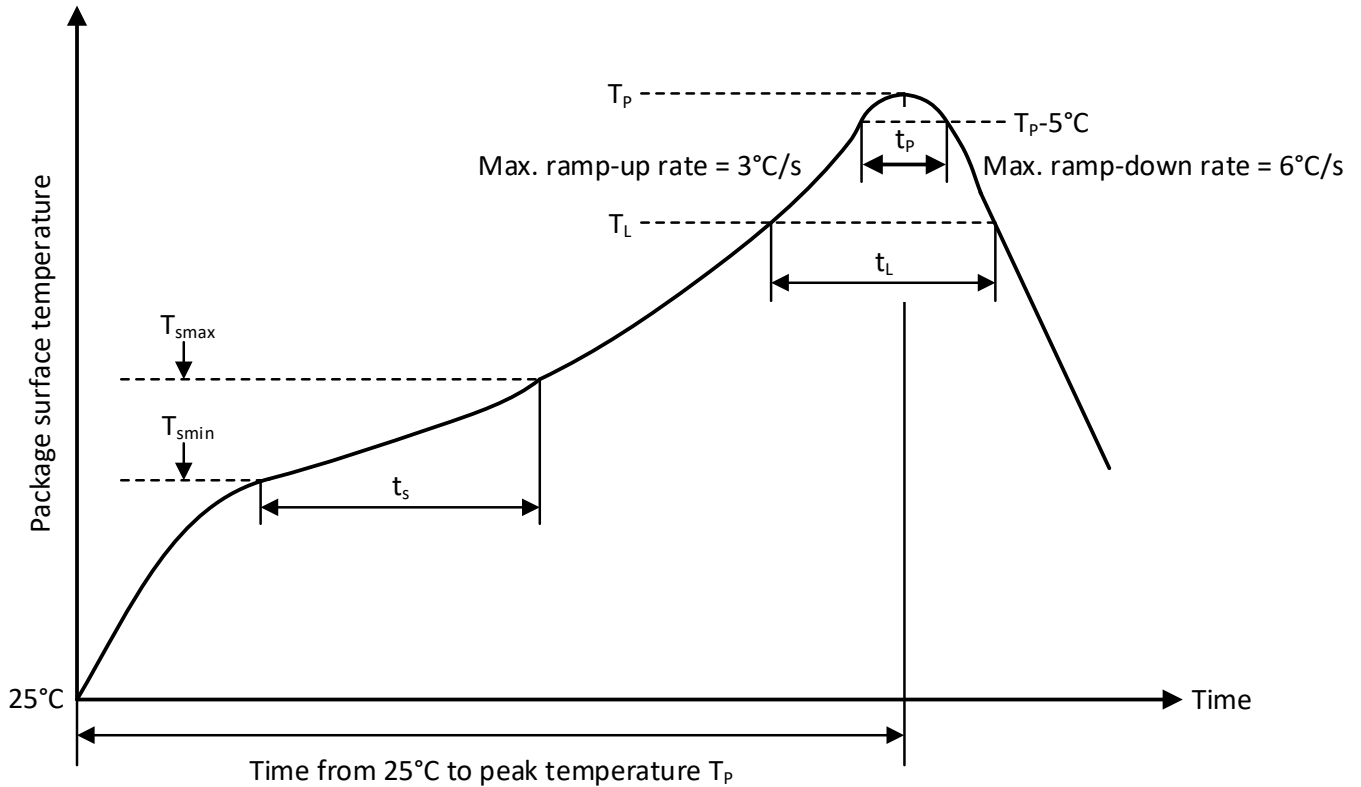

Figure 11-1. Soldering Temperature (reflow) Profile

Table 11-1. Soldering Temperature Parameter

Profile Feature	Pb-Free Soldering
Ramp-up rate ( $T_L = 217^\circ\text{C}$ to peak $T_p$ )	3°C/s max
Time $t_s$ of preheat temp ( $T_{smin} = 150^\circ\text{C}$ to $T_{smax} = 200^\circ\text{C}$ )	60~120 seconds
Time $t_L$ to be maintained above 217°C	60~150 seconds
Peak temperature $T_p$	260°C
Time $t_p$ within 5°C of actual peak temp	30 seconds max
Ramp-down rate (peak $T_p$ to $T_L = 217^\circ\text{C}$ )	6°C/s max
Time from 25°C to peak temperature $T_p$	8 minutes max



## 12 Tape and Reel Information

## REEL DIMENSIONS

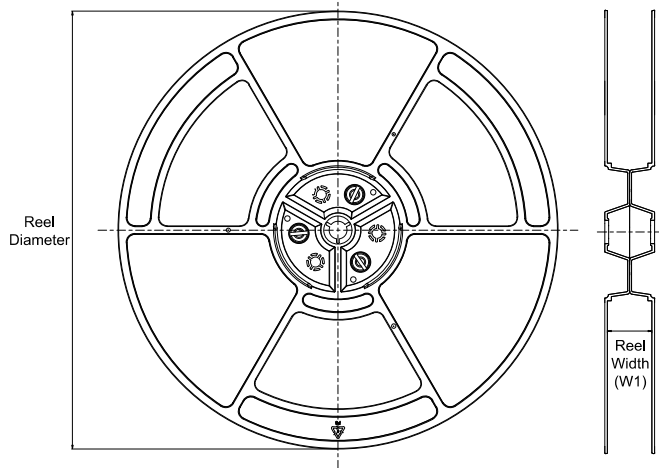

## TAPE DIMENSIONS

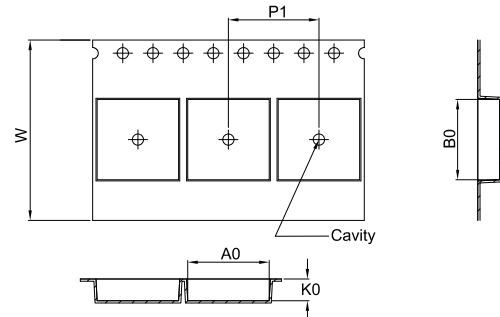

A0	Dimension designed to accommodate the component width
B0	Dimension designed to accommodate the component length
K0	Dimension designed to accommodate the component thickness
W	Overall width of the carrier tape
P1	Pitch between successive cavity centers

## QUADRANT ASSIGNMENTS FOR PIN 1 ORIENTATION IN TAPE

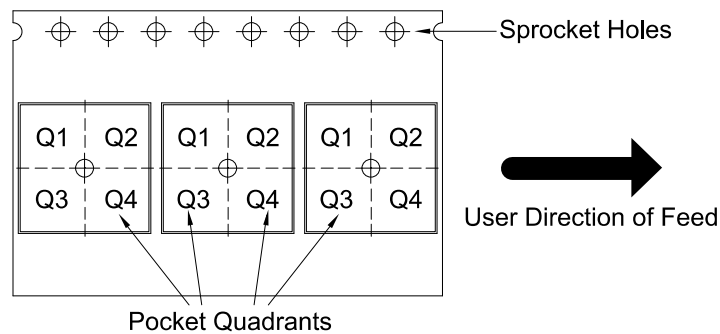

\*All dimensions are nominal

Device	Package Type	Package Drawing	Pins	SPQ	Reel Diameter (mm)	Reel Width W1 (mm)	A0 (mm)	B0 (mm)	K0 (mm)	P1 (mm)	W (mm)	Pin1 Quadrant
CA-IS1204W	SOIC	W	16	1000	330	16.4	10.8	10.7	2.9	12.0	24.0	Q1

### 13 Important Notice

The above information is for reference only and is used to assist Chipanalog customers in design and development. Chipanalog reserves the right to change the above information due to technological innovation without prior notice.

Chipanalog products are all factory tested. The customers shall be responsible for self-assessment and determine whether it is applicable for their specific application. Chipanalog's authorization to use the resources is limited to the development of related applications that the Chipanalog products involved in. In addition, the resources shall not be copied or displayed. And Chipanalog shall not be liable for any claim, cost, and loss arising from the use of the resources.

#### Trademark Information

Chipanalog Inc. ®, Chipanalog® are trademarks or registered trademarks of Chipanalog.



<http://www.chipanalog.com>