

CA-IS302x Low-Power Bidirectional I²C Isolators

1. Features

- **Bidirectional Data Transfer from DC to 2.0MHz**
- **Robust Galvanic Isolation of Digital Signals**
 - High lifetime: >40 years
 - Withstands up to 3.75kV_{RMS} (narrow-body package) and 5kV_{RMS} (wide-body packages) isolation rating for 60s (V_{ISO})
 - Narrow-body and wide-body Packages (4mm or 8mm Creepage and Clearance)
 - ±150 kV/μs typical CMTI
 - Schmitt trigger inputs for high noise immunity
 - High electromagnetic immunity and withstands ±10kV surge
 - ±8kV Human Body Model ESD Protection
- **3.0V to 5.5V Wide Supply Operation**
- **Wide Operating Temperature Range: -40°C to 125°C**
- **RoHS-Compliant Packages**
 - Narrow-body SOIC8-NB(S) package
 - Wide-body SOIC8-WB(G) package
 - Wide-body SOIC16-WB(W) package
- **Open-drain Outputs**
 - 3.5mA Side A sink current capability
 - 35mA Side B sink current capability
- **Safety Regulatory Approvals**
 - VDE certification according to DIN EN IEC60747-17(VDE 0884-17):2021-10
 - UL certification according to UL1577
 - CQC certification according to GB4843.1-2022

2. Applications

- I²C, SMBus, PMBus™ Interfaces
- Motor control systems
- Medical Equipment
- Battery Management
- Instrumentation

3. General Description

The CA-IS302x devices are complete dual-channel, galvanic digital isolators with up to 3.75kV_{RMS} (narrow-body package)/5kV_{RMS} (wide-body package) isolation rating and ±150kV/μs typical CMTI. All device versions have Schmitt trigger inputs for high noise immunity and each isolation channel has a logic input and output buffer separated by capacitive silicon dioxide (SiO₂) insulation barrier to provide high electromagnetic immunity and low EMI. These devices feature high-integration design and only require fewer external components, V_{DDA}, V_{DDB} bypass capacitors and pull-up resistors, to build an isolated I²C interface.

This family of devices operates from DC to 2.0MHz. The CA-IS3020 offers two bidirectional, open-drain channels for applications, such as multi-master I²C, that require data and clock to be transmitted in both directions on the same line. The CA-IS3021 provides an isolated I²C compatible interface supporting master mode only, with a unidirectional clock (SCL), and bidirectional data (SDA). All devices feature independent 3.0V to 5.5V supplies on each side of the isolator and the logic levels are set independently on either side by V_{DDA} and V_{DDB}. A simplified block diagram for a single CA-IS302x bidirectional channel is shown in the figure below.

The CA-IS302x series of devices are specified over -40°C to +125°C operating temperature range and are available in 8-pin SOIC narrow body package, 8-pin SOIC wide body package and 16-pin SOIC wide body package. The wide temperature range and high isolation voltage make the devices ideal for use in harsh industrial environments.

Device information

PART NUMBER	PACKAGE	BODY SIZE (NOM)
CA-IS3020 CA-IS3021	SOIC8(S)	4.90mm ×3.90 mm
	SOIC8-WB(G)	5.85 mm ×7.50 mm
	SOIC16-WB(W)	10.30 mm × 7.50 mm

CA-IS302x functional block diagram

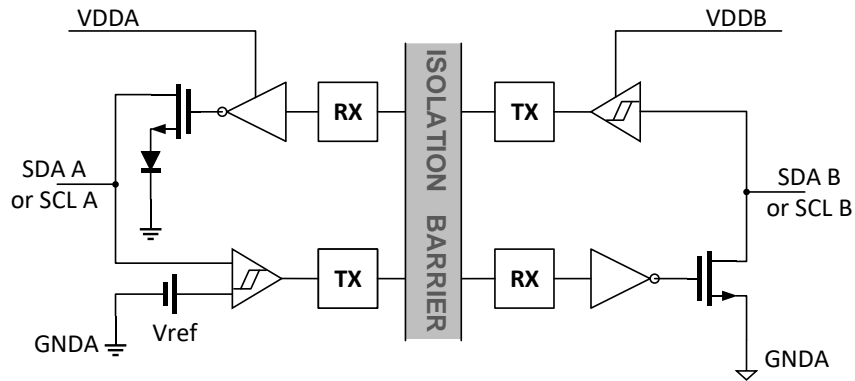

4. Ordering Information

Table. 4-1 Ordering Information

Part Number	# of Bidirectional Channels	# of Unidirectional Channels	Rated Voltage (V _{RMS})	Default Output	Package
CA-IS3020S	2	0	3.75	Open drain	SOIC8
CA-IS3020G	2	0	5.0	Open drain	SOIC8-WB
CA-IS3020W	2	0	5.0	Open drain	SOIC16-WB
CA-IS3021S	1	1	3.75	Open drain	SOIC8
CA-IS3021G	1	1	5.0	Open drain	SOIC8-WB
CA-IS3021W	1	1	5.0	Open drain	SOIC16-WB

Contents

1. Features	1	7.11. Switching Characteristics	12
2. Applications	1	8. Parameter Measurement Information	13
3. General Description	1	9. Detailed Description	14
4. Ordering Information	2	9.1. Overview	14
5. Revision History	3	9.2. Functional Block Diagrams.....	14
6. Pin Configuration and Description	4	9.3. Device Operation Modes	15
7. Specifications	6	10. Application Information	15
7.1. Absolute Maximum Ratings ¹	6	10.1. Overview	15
7.2. ESD Ratings.....	6	10.2. Typical Application	16
7.3. Recommended Operating Conditions	6	11. Package Information	17
7.4. Thermal Information	7	11.1. 8-Pin Narrow Body SOIC Package	17
7.5. Power Ratings.....	7	11.2. 8-Pin Wide Body SOIC Package	18
7.6. Insulation Specifications	8	11.3. 16-Pin Wide Body SOIC Package	19
7.7. Safety-Related Certifications	9	12. Soldering Temperature (reflow) Profile	20
7.8. Electrical Characteristics	10	13. Tape and Reel Information	21
7.9. Supply Current Characteristics	11	14. Important statement	22
7.10. Timing Requirements	11		

5. Revision History

Revision Number	Description	Revision Date	Page Changed
Version 1.00	N/A		N/A
Version 1.01	Change POD and Tape information	2023/02/09	18,19,20,22
Version 1.02	Update VDE information	2023/09/13	8,9
Version 1.03	Update VDE, UL, CQC, TUV information Update the test conditions of V_{IOSM}	2024/04/13	1,8,9

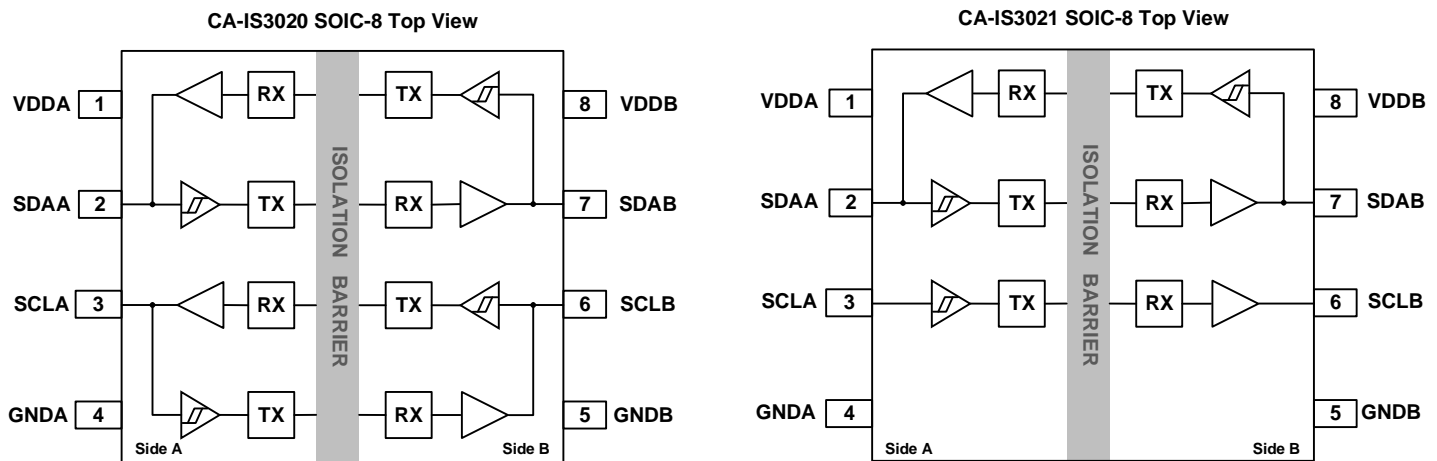
6. Pin Configuration and Description

Figure. 6-1 CA-IS3020/CA-IS3021 SOIC-8 and SOIC8-WB Top View
Table. 6-1 CA-IS3020S/CA-IS3020G pin Description

Pin name	Pin number	Type	Description
VDDA	1	Power	Power supply for side A.
SDAA	2	Digital I/O	Bidirectional data input/output on side A. SDAA is translated to/from SDAB and is an open-drain output.
SCLA	3	Digital I/O	Bidirectional clock input/output on side A. SCLA is translated to/from SCLB and is an open-drain output.
GNDA	4	Ground	Ground reference for side A.
GNDB	5	Ground	Ground reference for side B.
SCLB	6	Digital I/O	Bidirectional clock input/output on side B. SCLB is translated to/from SCLA and is an open-drain output.
SDAB	7	Digital I/O	Bidirectional data input/output on side B. SDAB is translated to/from SDAA and is an open-drain output.
VDDB	8	Power	Power supply for side B.

Table. 6-2 CA-IS3021S/C-IS3021G pin Description

Pin name	Pin number	Type	Description
VDDA	1	Power	Power supply for side A.
SDAA	2	Digital I/O	Bidirectional data input/output on side A. SDAA is translated to/from SDAB and is an open-drain output.
SCLA	3	Digital I/O	Clock input on side A. SCLA is translated to SCLB.
GNDA	4	Ground	Ground reference for side A.
GNDB	5	Ground	Ground reference for side B.
SCLB	6	Digital I/O	Clock output on side B. SCLB is translated from SCLA and is an open-drain output.
SDAB	7	Digital I/O	Bidirectional data input/output on side B. SDAB is translated to/from SDAA and is an open-drain output.
VDDB	8	Power	Power supply for side B.

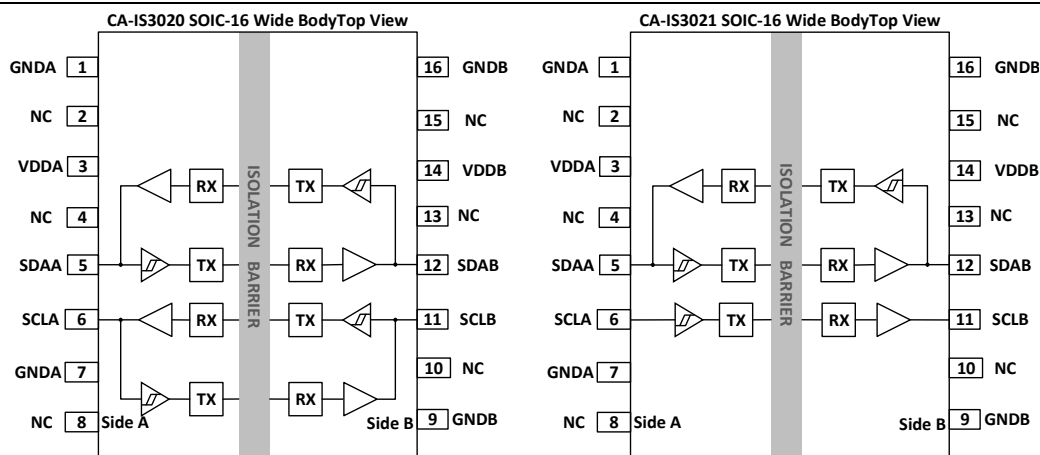

Figure. 6-2 CA-IS3020/CA-IS3021 SOIC16-WB Top View

Table. 6-3 CA-IS3020W pin Description

Pin name	Pin number	Type	Description
GNDA	1, 7	Ground	Ground reference for side A.
NC	2, 4, 8	--	No connect. Do not connect these pins externally.
VDDA	3	Power	Power supply for side A.
SDAA	5	Digital I/O	Bidirectional data input/output on side A. SDAA is translated to/from SDAB and is an open-drain output.
SCLA	6	Digital I/O	Bidirectional clock input/output on side A. SCLA is translated to/from SCLB and is an open-drain output.
GNDB	9, 16	Ground	Ground reference for side B.
NC	10, 13, 15	--	No connect. Do not connect these pins externally.
SCLB	11	Digital I/O	Bidirectional clock input/output on side B. SCLB is translated to/from SCLA and is an open-drain output.
SDAB	12	Digital I/O	Bidirectional data input/output on side B. SDAB is translated to/from SDAA and is an open-drain output.
VDDB	14	Power	Power supply for side B.

Table. 6-4 CA-IS3021W pin Description

Pin name	Pin number	Type	Description
GNDA	1, 7	Ground	Ground reference for side A.
NC	2, 4, 8	--	No connect. Do not connect these pins externally.
VDDA	3	Power	Power supply for side A.
SDAA	5	Digital I/O	Bidirectional data input/output on side A. SDAA is translated to/from SDAB and is an open-drain output.
SCLA	6	Digital I/O	Clock input on side A. SCLA is translated to SCLB.
GNDB	9, 16	Ground	Ground reference for side B.
NC	10, 13, 15	--	No connect. Do not connect these pins externally.
SCLB	11	Digital I/O	Clock output on side B. SCLB is translated from SCLA and is an open-drain output.
SDAB	12	Digital I/O	Bidirectional data input/output on side B. SDAB is translated to/from SDAA and is an open-drain output.
VDDB	14	Power	Power supply for side B.

7. Specifications

7.1. Absolute Maximum Ratings¹

Parameters		Minimum Value	Maximum Value	Unit
V _{DDA} , V _{DDB}	Power supply voltage ²	-0.5	6.0	V
SDAA, SCLA	Input/Output voltage	-0.5	V _{DDA} +0.5 ³	V
SDAB, SCLB	Input/Output voltage	-0.5	V _{DDB} +0.5 ³	V
I _{OA}	Output Current	-20	20	mA
I _{OB}	Output Current	-100	100	mA
T _J	Junction temperature		150	°C
T _{STG}	Storage temperature	-65	150	°C

Notes:

- The stresses listed under “Absolute Maximum Ratings” are stress ratings only, not for functional operation condition. Exposure to absolute maximum rating conditions for extended periods may cause permanent damage to the device.
- All voltage values except differential I/O bus voltages are with respect to the local ground terminal (GNDA or GNDB) and are peak voltage values.
- The maximum voltage must not be exceed 6 V.

7.2. ESD Ratings

			Numerical value	Unit
V _{ESD} Electrostatic discharge	Human body model (HBM), per ANSI/ESDA/JEDEC JS-001, all pins ¹		±8000	V
	Charged device model (CDM), per JEDEC Specification JESD22-C101, all pins ²		±2000	

Notes:

- Per JEDEC document JEP155, 500V HBM allows safe manufacturing of standard ESD control process.
- Per JEDEC document JEP157, 250V HBM allows safe manufacturing of standard ESD control process.

7.3. Recommended Operating Conditions

Parameters		Minimum Value	Maximum Value	Unit
V _{DDA} , V _{DDB}	Power supply voltage	3.0	5.5	V
V _{SDDA} , V _{VSCLA}	A side input voltage	0	V _{DDA}	V
V _{SDDB} , V _{VSCLB}	B side input voltage	0	V _{DDB}	V
V _{ILA}	A side Input low voltage	0	0.5	V
V _{IHA}	A side Input high voltage	0.7xV _{DDA}	V _{DDA}	V
V _{ILB}	B side Input low voltage	0	0.3xV _{DDB}	V
V _{IHB}	B side Input high voltage	0.7xV _{DDB}	V _{DDB}	V
I _{OLA}	A side Output current (low level)	0.5	3.5	mA
I _{OLB}	B side Output current (low level)	0.5	35	mA
C _A	Maximum load capacitance on A side		40	pF
C _B	Maximum load capacitance on B side		400	pF
f _{MAX} ¹	Maximum Frequency		2	MHz
T _A	Environmental temperature	-40	125	°C
T _J	Junction temperature	-40	150	°C

Note:

- This maximum signal transmission rate is the maximum signal frequency at the maximum bus capacitance load and the maximum pull-down current. If the capacitance load is smaller, a higher signal transmission rate is possible.

7.4. Thermal Information

Thermal Metric	CA-IS302x			Unit
	W(SOIC-16)	G(SOIC-8)	S(SOIC-8)	
$R_{\theta JA}$ Junction-to-ambient thermal resistance	86.5	92.3	109.0	°C/W

7.5. Power Ratings

PARAMETER	TEST CONDITIONS	MIN	TYP	MAX	Unit
P_D Maximum power dissipation (both sides)	$V_{DDA} = V_{DDB} = 5.5 \text{ V}$, $T_J = 150 \text{ °C}$, $C_A = 40 \text{ pF}$, $C_B = 400 \text{ pF}$; Input a 1-MHz 50% duty cycle clock signal			86	mW
P_{DA} Maximum power dissipation (side-A)				34	mW
P_{DB} Maximum power dissipation (side-B)				52	mW

7.6. Insulation Specifications

Parameters		Test conditions	Value			Unit
			W	G	S	
CLR	External clearance	Shortest terminal-to-terminal distance through air	8	8	4	mm
CPG	External creepage	Shortest terminal-to-terminal distance across the package surface	8	8	4	mm
DTI	Distance through the insulation	Minimum internal gap (internal clearance)	28	28	28	μm
CTI	Comparative tracking index	DIN EN 60112 (VDE 0303-11); IEC 60112	>600	>600	>600	V
Material group		In accordance with IEC 60664-1	I	I	I	
IEC 60664-1 over-voltage category		Rated mains voltage ≤ 150 V _{RMS}	I-IV	I-IV	I-IV	
		Rated mains voltage ≤ 300 V _{RMS}	I-IV	I-IV	I-IV	
		Rated mains voltage ≤ 600 V _{RMS}	I-IV	I-IV	N/A	
		Rated mains voltage ≤ 1000 V _{RMS}	I-III	I-III	N/A	
DIN V VDE V 0884-17:2021-10¹						
V _{IORM}	Maximum repetitive peak isolation voltage	AC voltage (bipolar)	1414	1414	566	V _{PK}
V _{IOWM}	Maximum operating isolation voltage	AC voltage; time-dependent dielectric breakdown (TDDB) test	1000	1000	400	V _{RMS}
		DC voltage	1414	1414	566	V _{DC}
V _{IOTM}	Maximum transient isolation voltage	V _{TEST} = V _{IOTM} , t=60 s (certified); V _{TEST} = 1.2 × V _{IOTM} , t=1 s (100% product test)	7070	7070	5300	V _{PK}
V _{IOSM}	Maximum surge isolation voltage ²	Test method in accordance with IEC 62368-1, 1.2/50 μs waveform, V _{TEST} = 1.6 × V _{IOSM} (certified, G/W) V _{TEST} = 1.3 × V _{IOSM} (certified, S)	8000	8000	5000	V _{PK}
Q _{pd}	Apparent charge ³	Method a, after input/output safety test of the sub-category 2/3, V _{ini} = V _{IOTM} , t _{ini} = 60 s; V _{pd(m)} = 1.2 × V _{IORM} , t _m = 10 s	≤5	≤5	≤5	pC
		Method a, after environmental test of the sub-category 1, V _{ini} = V _{IOTM} , t _{ini} = 60 s; V _{pd(m)} = 1.6 × V _{IORM} , t _m = 10 s	≤5	≤5	≤5	
		Method b1, routine test (100% production test) and preprocessing (sample test) V _{ini} = 1.2 × V _{IOTM} , t _{ini} = 1 s; V _{pd(m)} = 1.875 × V _{IORM} , t _m = 1 s (certified, G/W) V _{pd(m)} = 1.5 × V _{IORM} , t _m = 1 s (certified, S)	≤5	≤5	≤5	
C _{IO}	Barrier capacitance, input to output ⁴	V _{IO} = 0.4 × sin(2πft), f = 1 MHz	~0.5	~0.5	~0.5	pF
R _{IO}	Isolation resistance ⁴	V _{IO} = 500 V, T _A = 25°C	>10 ¹²	>10 ¹²	>10 ¹²	Ω
		V _{IO} = 500 V, 100°C ≤ T _A ≤ 125°C	>10 ¹¹	>10 ¹¹	>10 ¹¹	
		V _{IO} = 500 V at T _S = 150°C	>10 ⁹	>10 ⁹	>10 ⁹	
Contaminant level			2	2	2	
UL 1577						
V _{ISO}	Maximum isolation voltage	V _{TEST} = V _{ISO} , t = 60 s (certified) V _{TEST} = 1.2 × V _{ISO} , t = 1 s (100% production test)	5000	5000	3750	V _{RMS}
Notes:						
1. This coupler is suitable for “safe electrical insulation” only within the safety ratings. Compliance with the safety ratings shall be ensured by means of suitable protective circuits.						
2. Devices are immersed in oil during surge characterization.						
3. The characterization charge is discharging charge (pd) caused by partial discharge.						
4. Capacitance and resistance are measured with all pins on field-side and logic-side tied together.						

7.7. Safety-Related Certifications

VDE	UL	CQC
Certified according to DIN EN IEC60747-17(VDE 0884-17):2021-10; EN IEC60747-17:2020+AC:2021	Certified according to UL 1577 Component Recognition Program	Certified according to GB4943.1-2011 and GB 8898-2011
Maximum transient isolation voltage: 5300V _{pk} (SOIC8-NB), 7070V _{pk} (SOIC8-WB) and 7070V _{pk} (SOIC16-WB) Maximum repetitive peak isolation voltage: 566V _{pk} (SOIC8-NB), 1414V _{pk} (SOIC8-WB) and 1414V _{pk} (SOIC16-WB) Maximum surge isolation voltage: 5000V _{pk} (SOIC8-NB), 8000V _{pk} (SOIC8-WB) and 8000V _{pk} (SOIC16-WB)	SOIC8: 3750 V _{RMS} ; SOIC8-NB: 5000 V _{RMS} ; SOIC8-WB: 5000 V _{RMS} ;	SOIC8-WB: Reinforced insulation (Altitude ≤ 5000 m)
Basic insulation Certificate number: 40052786 Reinforced insulation Certificate number: 40057278	Certificate number: E511334	Certificate number: CQC23001406424

7.8. Electrical Characteristics
Over recommended operating conditions, unless otherwise specified

Parameters		Test conditions	Minimum Value	Typical Value	Maximum Value	Unit
Side A						
V _{ILTA}	Logic low input threshold (SDAA and SCLA)		470	500	520	mV
V _{IHTA}	Logic high input threshold (SDAA and SCLA)		500	560	620	mV
V _{HYS A}	Voltage input hysteresis	V _{IHTA} - V _{ILTA}	40	60	80	mV
V _{OLA}	Logic low output voltage (SDAA and SCLA) ¹	0.5mA ≤ (I _{SDAA} and I _{SCLA}) ≤ 3.5mA	630	700	760	mV
ΔV _{OITA}	Logic-low output voltage to logic-high input voltage threshold difference (SDAA and SCLA) ^{1, 2}	0.5mA ≤ (I _{SDAA} and I _{SCLA}) ≤ 3.5mA	100			mV
Side B						
V _{ILTB}	Logic low input threshold (SDAB and SCLB)		1.13	1.33	1.53	V
V _{IHTB}	Logic low output voltage (SDAB and SCLB)		1.55	1.75	1.97	V
V _{HYS B}	Voltage input hysteresis	V _{IHTB} - V _{ILTB}	0.30	0.42	0.54	V
V _{OLB}	Logic-low output voltage (SDAB and SCLB)	0.5mA ≤ (I _{SDAB} and I _{SCLB}) ≤ 3.5mA			0.4	V
Both Sides						
I _L	Input leakage currents, SDAA, SCLA, SDA2, and SCL2	V _{SDAA} = V _{SCLA} = V _{DDA} V _{SDAB} = V _{SCLB} = V _{ddb}			1	μA
C _i	Input capacitance to local ground (SDA1, SCL1, SDA2, and SCL2)			3		pF
CMTI	Common mode transient immunity	see Figure 8-3	100	150		kV/μS
V _{DDUV}	VDD_ Undervoltage-lockout threshold ³		1.95	2.24	2.53	V
Notes:						
1. This parameter apply to the CA-IS3020 (SDAA, SCLA) and CA-IS3021 SDAA bidirectional lines only. 2. ΔV _{OITA} = V _{OLA} - V _{IHTA} . This is the minimum difference between logic-low output voltage and a logic-high input voltage. 3. Any V _{DD_} voltage on both side, less than the minimum will ensure device lockout. V _{DD_} voltage on both side A and side B greater than the maximum will prevent device lockout.						

7.9. Supply Current Characteristics

Over recommended operating conditions, unless otherwise specified, see Figure 8-1 for more information.

Parameters	Test conditions		Minimum Value	Typical Value	Maximum Value	Unit
3 V ≤ V_{DDA}, V_{DDB} ≤ 3.6 V						
CA-IS3020	V _{SDAA} = V _{SCLA} = GNDA; V _{SDAB} = V _{SCLB} = GNDB; R1 = R2 = OPEN; C1 = C2 = OPEN	I _{DDA}		4.9	5.7	mA
		I _{DDB}		4.7	5.2	
	V _{SDAA} = V _{SCLA} = V _{DDA} ; V _{SDAB} = V _{SCLB} = V _{DDB} ; R1 = R2 = OPEN; C1 = C2 = OPEN	I _{DDA}		2.4	2.8	
		I _{DDB}		2.2	2.6	
CA-IS3021	V _{SDAA} = V _{SCLA} = GNDA; V _{SDAB} = V _{SCLB} = GNDB; R1 = R2 = OPEN; C1 = C2 = OPEN	I _{DDA}		2.9	4.4	
		I _{DDB}		2.4	3.7	
	V _{SDAA} = V _{SCLA} = V _{DDA} ; V _{SDAB} = V _{SCLB} = V _{DDB} ; R1 = R2 = OPEN; C1 = C2 = OPEN	I _{DDA}		1.7	2.6	
		I _{DDB}		1.8	2.8	
4.5 V ≤ V_{DDA}, V_{DDB} ≤ 5.5V						
CA-IS3020	V _{SDAA} = V _{SCLA} = GNDA; V _{SDAB} = V _{SCLB} = GNDB; R1 = R2 = OPEN; C1 = C2 = OPEN	I _{DDA}		5.0	5.7	mA
		I _{DDB}		4.7	5.2	
	V _{SDAA} = V _{SCLA} = V _{DDA} ; V _{SDAB} = V _{SCLB} = V _{DDB} ; R1 = R2 = OPEN; C1 = C2 = OPEN	I _{DDA}		2.4	2.8	
		I _{DDB}		2.2	2.6	
CA-IS3021	V _{SDAA} = V _{SCLA} = GNDA; V _{SDAB} = V _{SCLB} = GNDB; R1 = R2 = OPEN; C1 = C2 = OPEN	I _{DDA}		3.0	4.5	
		I _{DDB}		2.5	3.8	
	V _{SDAA} = V _{SCLA} = V _{DDA} ; V _{SDAB} = V _{SCLB} = V _{DDB} ; R1 = R2 = OPEN; C1 = C2 = OPEN	I _{DDA}		1.8	2.7	
		I _{DDB}		1.9	2.9	

7.10. Timing Requirements

		Minimum Value	Typical Value	Maximum Value	Unit
t _{SP}	Input noise filter	10	25		ns

7.11. Switching Characteristics
over recommended operating conditions, unless otherwise specified

Parameters		Test conditions	Minimum Value	Typical Value	Maximum Value	Unit	
3 V ≤ (V_{DDA}, V_{DDB}) ≤ 3.6 V							
t _{FA}	Fall Time(SDAA, SCLA)	See figure 8-1 R1 = 953Ω C1 = 40pF	A side input from 0.7xV _{DDA} to 0.3xV _{DDA}	18	23	28	ns
			A side input from 0.9xV _{DDA} to 900mV	32	40	48	
t _{FB}	Fall Time (SDAB, SCLB)	See figure 8-1 R2 = 95.3Ω C2 = 400pF	B side input from 0.7xV _{DDB} to 0.3xV _{DDB}	12	16	20	
			B side input from 0.9xV _{DDB} to 400mV		30	60	
t _{PLHA-B}	Propagation Delay, Side A to Side B	See figure 8-1 R1 = 953Ω R2 = 95.3Ω C1 = C2 = 10pF	A side input = 0.55V to B side output = 0.7xV _{DDB}		100	135	
t _{PHLAB}	Propagation Delay, Side A to Side B		A side input = 0.7V to B side output = 0.4V		100	130	
PWD _{AB}	Pulse Width Distortion		t _{PHLAB} - t _{PLHAB}		7	30	
t _{PLHBA} ¹	Propagation Delay, Side B to Side A		B side input = 0.4xV _{DDB} to A side output = 0.7xV _{DDA}		80	100	
t _{PHLBA} ¹	Propagation Delay, Side B to Side A		B side input = 0.4xV _{DDB} to A side output = 0.9V		90	120	
PWD _{BA} ¹	Pulse Width Distortion		t _{PHLBA} - t _{PLHBA}		5	20	
t _{LOOPA} ¹	Loop propagation delay on Side A		See figure 8-2 R1 = 953Ω C1 = 40pF R2 = 95.3Ω C2 = 400pF	A side input = 0.4V to A side output = 0.3xV _{DDA}		200	
4.5 V ≤ (V_{DDA}, V_{DDB}) ≤ 5.5 V							
t _{FA}	Fall Time(SDAA, SCLA)	See figure 8-1 R1 = 1430Ω C1 = 40pF	A side input from 0.7xV _{DDA} to 0.3xV _{DDA}	10	12	14	ns
			A side input from 0.9xV _{DDA} to 900mV	40	50	60	
t _{FB}	Fall Time (SDAB, SCLB)	See figure 8-1 R2 = 143Ω C2 = 400pF	B side input from 0.7xV _{DDB} to 0.3xV _{DDB}	8	10	12	
			B side input from 0.9xV _{DDB} to 400mV	20	28	36	
t _{PLHAB}	Propagation Delay, Side A to Side B	See figure 8-1 R1 = 1430Ω R2 = 143Ω C1 = C2 = 10pF	A side input = 0.55V to B side output = 0.7xV _{DDB}		100	120	
t _{PHLAB}	Propagation Delay, Side A to Side B		A side input = 0.7V to B side output = 0.4V		70	90	
PWD _{AB}	Pulse Width Distortion		t _{PHLAB} - t _{PLHAB}		30	45	
t _{PLHBA} ¹	Propagation delay, side B to side A		B side input = 0.4xV _{DDB} to A side output = 0.7xV _{DDA}		110	130	
t _{PHLBA} ¹	Propagation delay, Side B to side A		B side input = 0.4xV _{DDB} to A side output = 0.9V		100	150	
PWD _{BA} ¹	Pulse Width Distortion		t _{PHLBA} - t _{PLHBA}		8	20	
t _{LOOPA} ¹	Loop propagation delay on side A		See figure 8-2 R1 = 1430Ω C1 = 40pF R2 = 143Ω C2 = 400pF	A side input = 0.4V to A side output = 0.3xV _{DDA}		210	
Note:							
1. This parameter apply to the CA-IS3020 (SDAA, SCLA) and CA-IS3021(SDAA) bidirectional lines only.							

8. Parameter Measurement Information

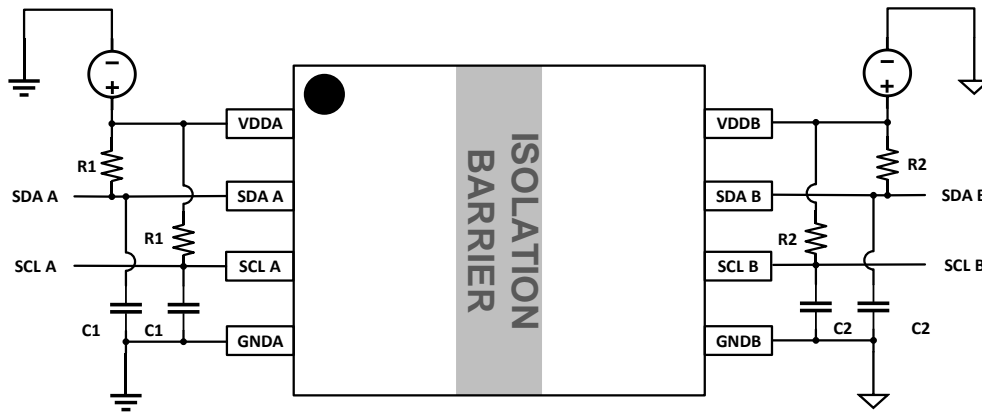

Figure 8-1 Test Circuit

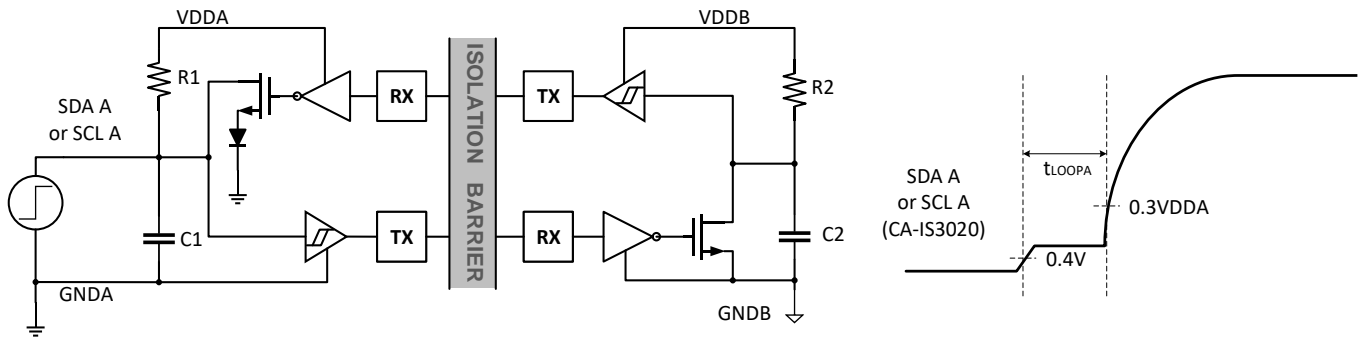

Figure 8-2 t_{LOOPA} Test Circuit and Timing Diagram

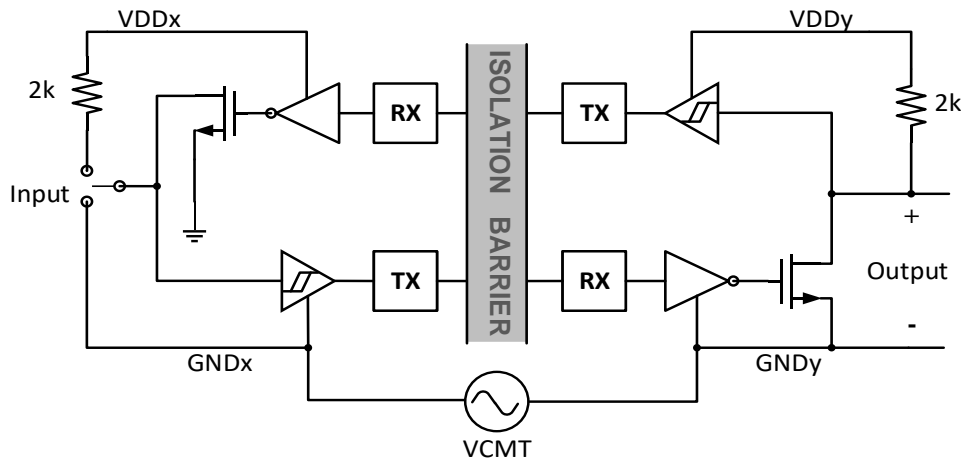

Figure 8-3 Common-Mode Transient Immunity Test Circuit

9. Detailed Description

9.1. Overview

The CA-IS302x family of devices is complete dual-channel, bidirectional galvanic digital isolators with up to $3.75kV_{RMS}$ (narrow-body package) or $5kV_{RMS}$ (wide-body package) isolation rating and $\pm 150kV/\mu s$ typical CMTI. All devices have Schmitt trigger inputs for high noise immunity and each isolation channel has logic input and output buffer separated by capacitive silicon dioxide (SiO_2) insulation barrier. The CA-IS3020 offers two bidirectional, open-drain channels for applications, such as multi-master I²C, that require data and clock to be transmitted in both directions on the same line. The CA-IS3021 provides an isolated I²C compatible interface supporting master mode only, with a unidirectional clock (SCL), and bidirectional data (SDA). All devices can support up to 2.0MHz operating frequency and feature independent 3.0V to 5.5V supplies (V_{DDA} and V_{DDB}) on each side of the isolator to setup the logic levels independently on either side, see *Table 9-1* for the CA-IS302x key features.

The CA-IS302x family are specified over the $-40^{\circ}C$ to $+125^{\circ}C$ operating temperature range. The wide temperature range and high isolation voltage make the devices ideal for use in harsh industrial environments.

Table 9- 1 Key Features

PART NUMBER	CHANNEL DIRECTION	RATED ISOLATION ¹	MAXIMUM FREQUENCY
CA-IS3020	Bidirectional(SCL) Bidirectional(SDA)	Narrow-body package: $3750V_{RMS}$, $5300 V_{PK}$ Wide-body package: $5000V_{RMS}$, $7071 V_{PK}$	2.0MHz
CA-IS3021	Unidirectional(SCL) Bidirectional(SDA)		
Note:			
1. For more details, please see the <i>Insulation Specifications</i> table.			

9.2. Functional Block Diagrams

Compared with inductive isolation, the CA-IS302x devices based on capacitive isolation can get low power at high frequency operation, reduces propagation delay and jitter, and provide good immunity to magnetic fields. See *Figure 9-1* and *Figure 9-2* the CA-IS302x function block diagram for more details. To build the bidirectional signal path, the CA-IS302x integrated two unidirectional isolated signal lines for each bidirectional line. All of output channels provide open-drain output to comply with the standard I²C interface. Side A is designed to connect to the low capacitance I²C node with up to 40pF of load capacitance, while side B is designed for connecting to a fully loaded I²C bus with up to 400 pF of load capacitance.

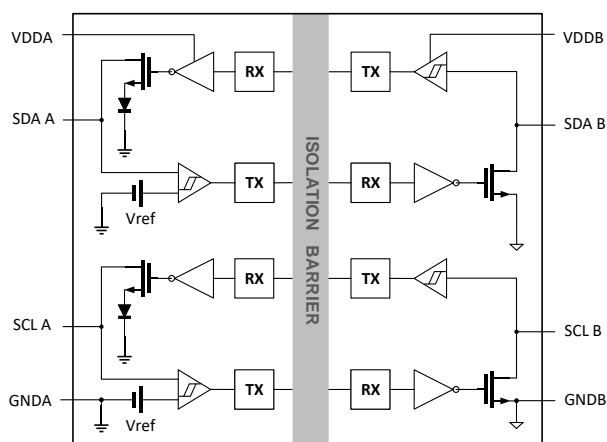
Figure. 9-1 The CA-IS3020 Block Diagram

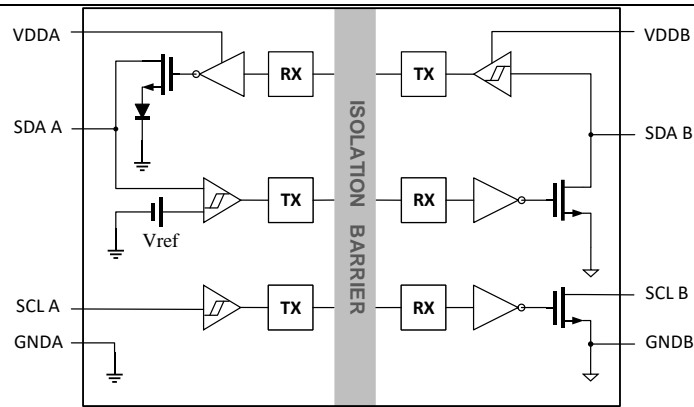

Figure. 9-2 The CA-IS3021 Block Diagram

9.3. Device Operation Modes

Table 9-2 lists the CA-IS302x functional modes. For optimal performance, ensure that the load capacitance on side A (C_A) is $\leq 40\text{pF}$, and the load capacitance on side B (C_B) is $\leq 400\text{pF}$. The maximum static output loading on side A is 3.5mA, while on side B, the maximum static output current is 35mA. For the bidirectional isolation channels, to prevent latch-up action, the A-side outputs comprise special buffers that regulate the logic-low voltage at approximately 700mV, and the maximum input logic-low voltage is 400mV. The internal comparator with hysteresis determines whether the logic-low level comes from the input or output based on the logic-low voltages at SDAA and SCLA pins. This prevents an output logic-low on side A from being accepted as an input low and subsequently transmitted to side B; thus preventing a latching action. The B side features conventional buffers that do not regulate logic-low output voltage. A logic-low on one side causes the corresponding pin on the other side to be pulled low while avoiding data latching within the device.

The V_{DDA} and V_{DDB} supplies are both internally monitored for undervoltage conditions with 1.95V minimum threshold and 2.53V maximum threshold. Undervoltage events can occur during power-up, power-down, or during normal operation due to a sagging supply voltage. When an undervoltage event is detected on either of the supplies ($V_{DDA} \leq 1.95\text{V}$ or/and $V_{DDB} \leq 1.95\text{V}$), all bidirectional outputs become high-impedance and are pulled high by the external pullup resistor on the open-drain outputs.

 Table 9- 2 Truth Table¹

POWER STATE	INPUT	OUTPUT
V_{DDA} or $V_{DDB} < 1.95\text{V}$	X	Hi-Z
V_{DDA} and $V_{DDB} > 2.53\text{V}$	L	L
V_{DDA} and $V_{DDB} > 2.53\text{V}$	H	Hi-Z
V_{DDA} and $V_{DDB} > 2.53\text{V}$	Hi-Z ²	Indeterminate

Notes:

- X = don't care; H = high level; L = low level; Hi-Z = high impedance.
- Invalid input condition as an I²C system requires that a pull-up resistor to VDD_ is connected on the bus.

10. Application Information

10.1. Overview

The Inter IC (I²C) bus is a simple, 2-wire bus for communication between different ICs (system controller, remote sensor, actuator etc. circuitry). 2-wire interfaces use only a data line (SDA) and a clock line (SCL) and allow to connect multiple slaves on the same bus without needing chip-select signals. Because 2-wire interfaces have only one data line, they can operate in half-duplex mode only, this means data can only be transmitted or received on a given cycle, also, the data line should be bidirectional. For the multi-master I²C applications, both data and clock lines need to transmit in both directions on the same line. The CA-IS302x family of digital isolators offers two bidirectional channels (CA-IS3020) or one unidirectional channel for clock and one

bidirectional channel for data (CA-IS3021), is ideal for use in I²C bus to provide the required isolation between different ground potentials of the system circuitry to prevent ground loop currents that otherwise may falsify the acquired data. The I²C bus can operate in Standard mode, Fast mode, or High-speed mode, with maximum data rates of 100kbps (Standard mode), 400kbps (Fast mode), 1.7Mbps (High-speed mode with $C_{bus} = 400\text{pF}$). The CA-IS302x digital isolators can support up to 2.0MHz operating frequency, thus can support most of I²C communication applications.

10.2. Typical Application

The CA-IS302x isolation ICs provide complete galvanic isolation between two power domains, protecting circuits from high common-mode transients and faults, eliminating ground loops. These devices do not require special power-supply sequencing, the logic levels are set independently on either side by V_{DDA} and V_{DDB} . The SDA_A, SCL_A, SDA_B, SCL_B pins have open-drain outputs, requiring pull-up resistors to their respective supplies for logic-high outputs. The output low voltages are guaranteed for sink currents of up to 35mA for side B, and 3.5mA for side A. So the minimum pullup resistors on the input lines must be selected in such a way that input current drawn is $\leq 3.5\text{mA}$ on side A and output current drawn is $\leq 35\text{mA}$ on side B. The maximum pull-up resistors on the input lines and output lines depend on the load and rise time requirements on the respective lines.

To reduce ripple and the chance of introducing data errors, bypass V_{DDA} and V_{DDB} with at least $0.1\mu\text{F}$ low-ESR ceramic capacitors to GND_A and GND_B respectively. Place the bypass capacitors as close to the power supply input pins as possible. *Figure 10-1* and *Figure 10-2* show typical operating circuit of the CA-IS3020 and CA-IS3021.

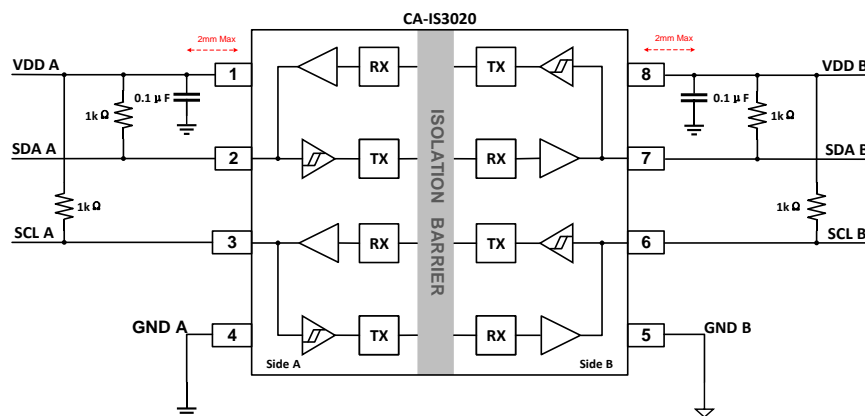

Figure. 10-1 The CA-IS3020 typical application circuit

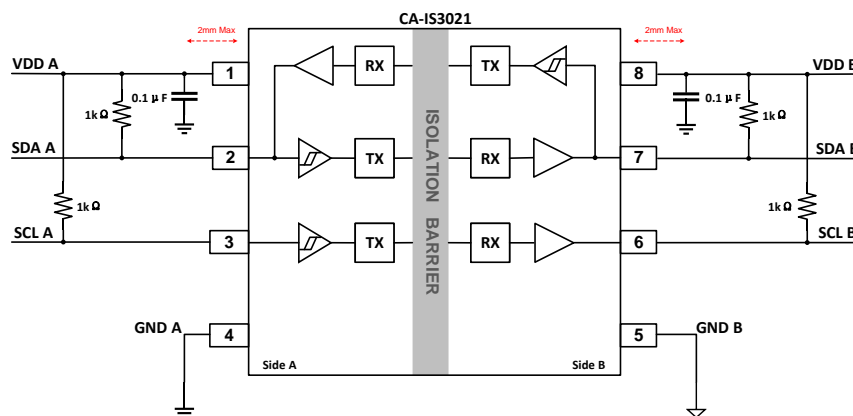
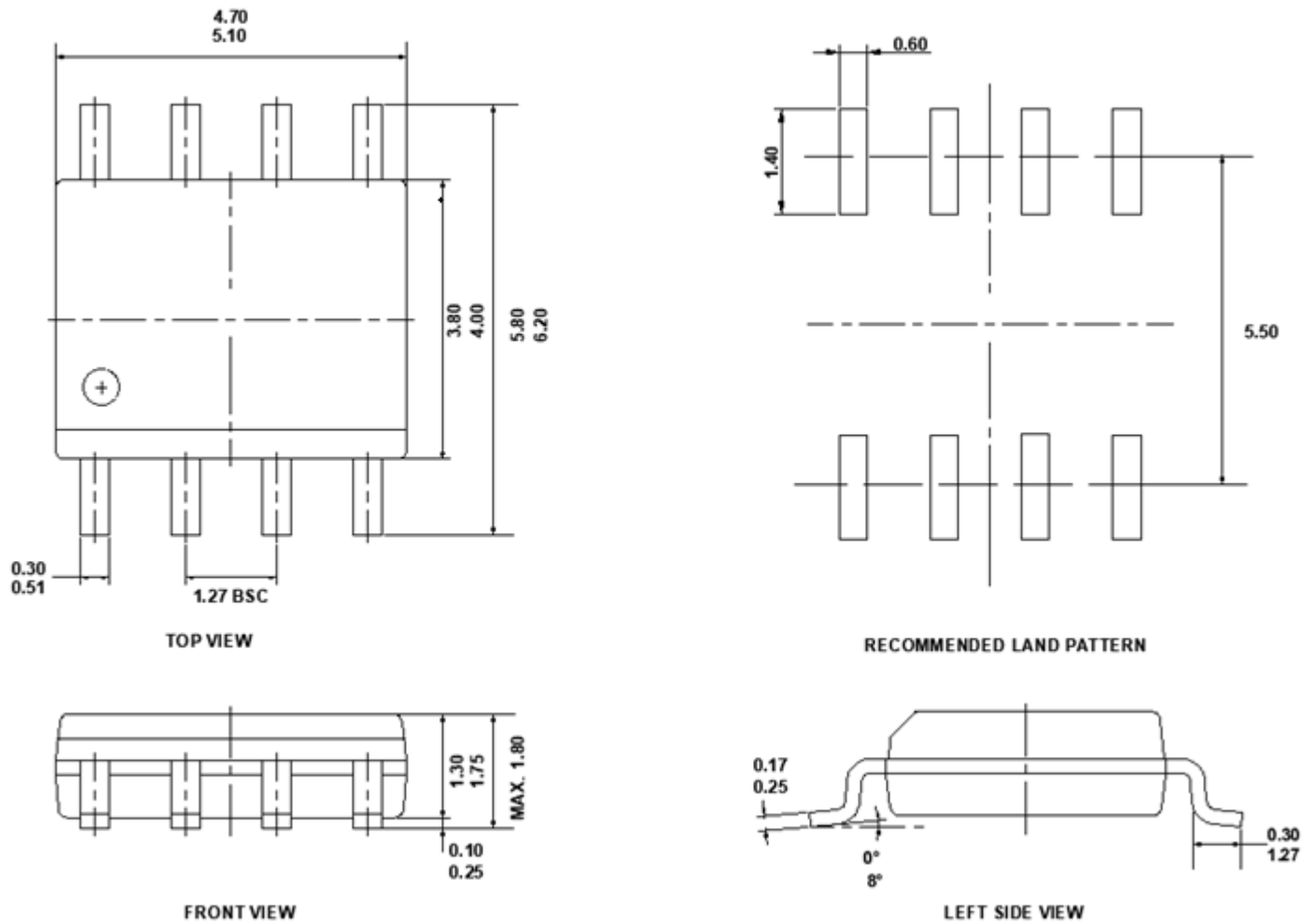

Figure. 10-2 The CA-IS3021 typical application circuit

11. Package Information

11.1. 8-Pin Narrow Body SOIC Package

The following diagrams provide the package details and the recommended land pattern details for the CA-IS302x digital isolator in 8-pin narrow body SOIC package. All values for the dimensions are shown in millimeters.



Note:

1. All dimensions are in millimeters, angles are in degrees.

11.2. 8-Pin Wide Body SOIC Package

The following diagrams provide the package details and the recommended land pattern details for the CA-IS302x digital isolator in 8-pin wide body SOIC package. All values for the dimensions are shown in millimeters.

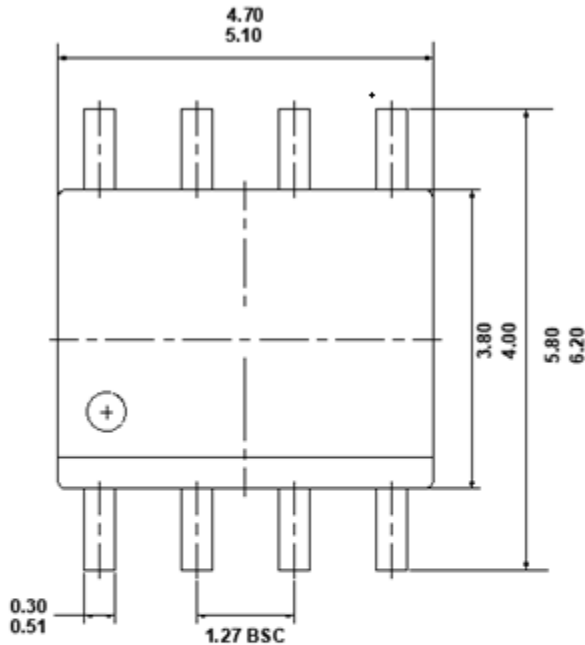

TOP VIEW

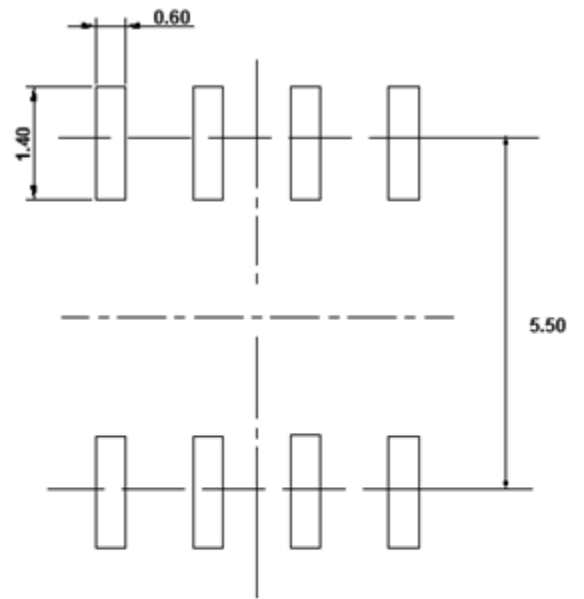

RECOMMENDED LAND PATTERN

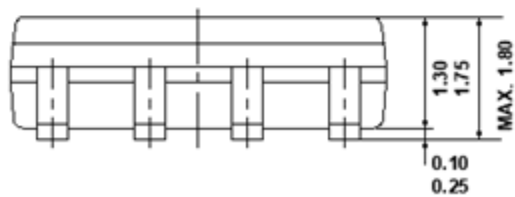

FRONT VIEW



LEFT SIDE VIEW

Note:

1. All dimensions are in millimeters, angles are in degrees.

11.3. 16-Pin Wide Body SOIC Package

The following diagrams provide the package details and the recommended land pattern details for the CA-IS302x digital isolator in 16-pin wide body SOIC package. All values for the dimensions are shown in millimeters.

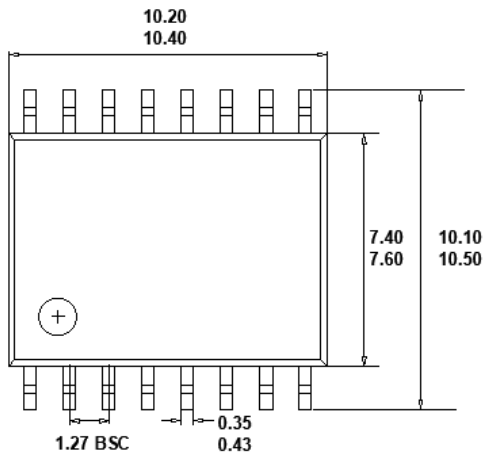

TOP VIEW

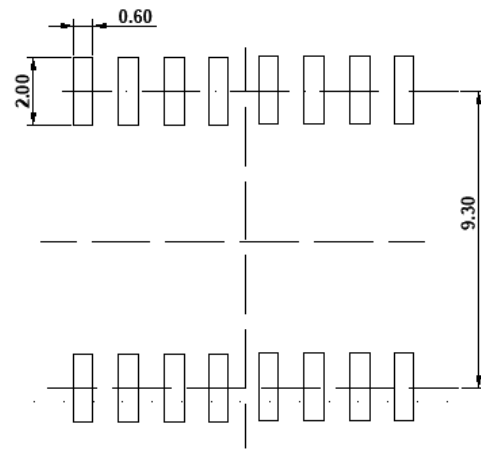

RECOMMENDED LAND PATTERN

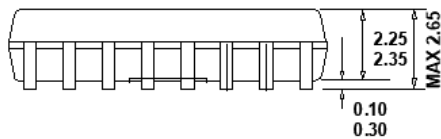

FRONT VIEW

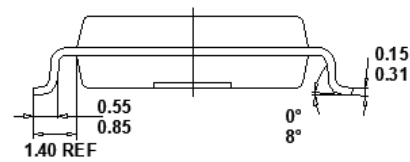

LEFT SIDE VIEW

Note:

1. All dimensions are in millimeters, angles are in degrees.

12. Soldering Temperature (reflow) Profile

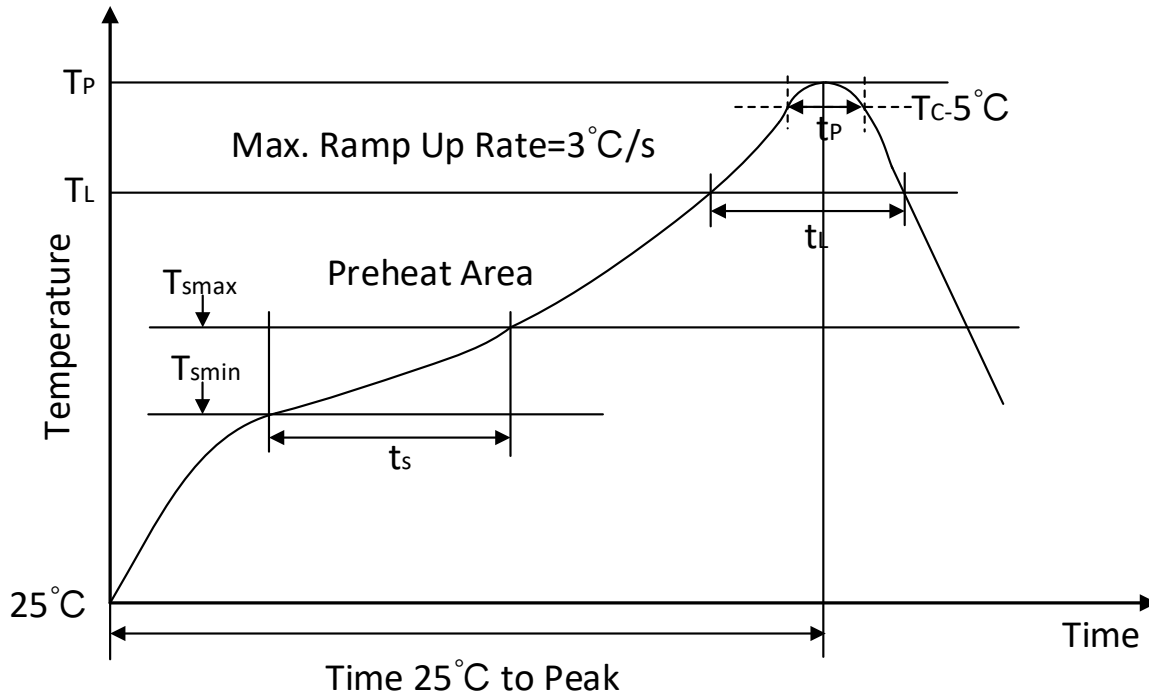

Figure. 12-1 Soldering Temperature (reflow) Profile

Table 12-1 Soldering Temperature Parameter

Profile Feature	Pb-Free Assembly
Average ramp-up rate(217°C to Peak)	3°C /second max
Time of Preheat temp(from 150°C to 200°C)	60-120 second
Time to be maintained above 217°C	60-150 second
Peak temperature	260°C +5/-0°C
Time within 5°C of actual peak temp	30 second
Ramp-down rate	6°C/second max.
Time from 25°C to peak temp	8 minutes max

13. Tape and Reel Information

REEL DIMENSIONS

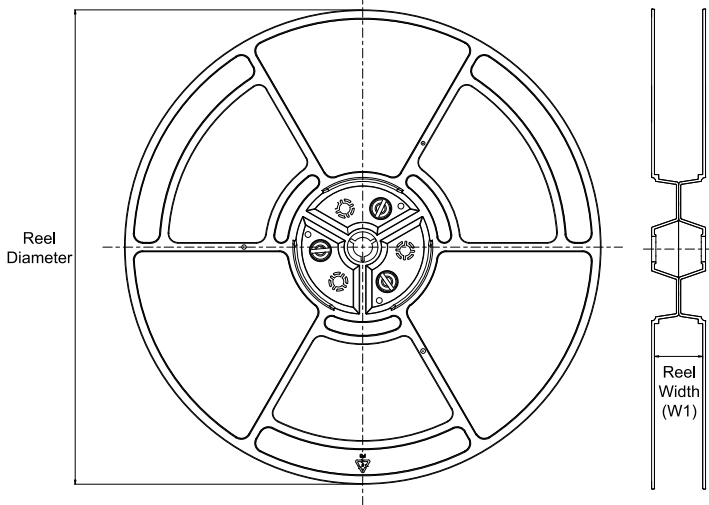

TAPE DIMENSIONS

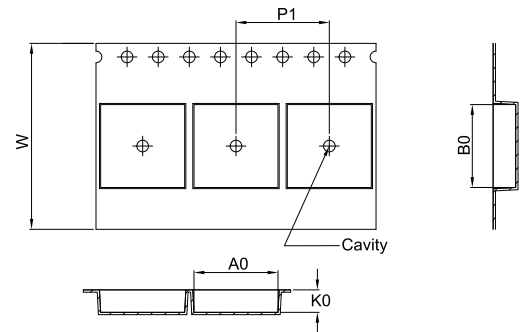

A0	Dimension designed to accommodate the component width
B0	Dimension designed to accommodate the component length
K0	Dimension designed to accommodate the component thickness
W	Overall width of the carrier tape
P1	Pitch between successive cavity centers

QUADRANT ASSIGNMENTS FOR PIN 1 ORIENTATION IN TAPE

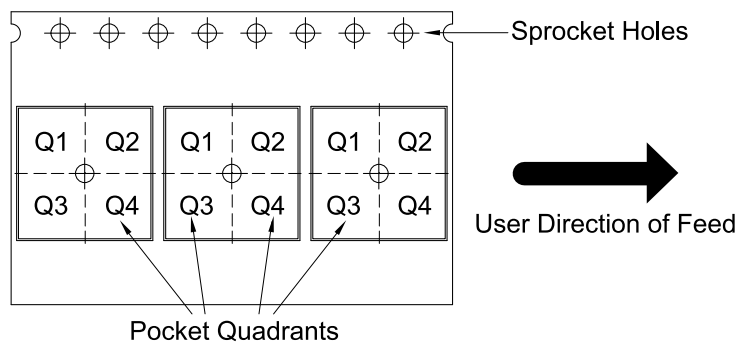

*All dimensions are nominal

Device	Package Type	Package Drawing	Pins	SPQ	Reel Diameter (mm)	Reel Width W1 (mm)	A0 (mm)	B0 (mm)	K0 (mm)	P1 (mm)	W (mm)	Pin1 Quadrant
CA-IS3020S	SOIC	S	8	2500	330	12.4	6.40	5.40	2.10	8.00	12.00	Q1
CA-IS3020G	SOIC	G	8	1000	330	16.4	11.95	6.15	3.20	16.00	16.00	Q1
CA-IS3021S	SOIC	S	8	2500	330	12.4	6.40	5.40	2.10	8.00	12.00	Q1
CA-IS3021G	SOIC	G	8	1000	330	16.4	11.95	6.15	3.20	16.00	16.00	Q1
CA-IS3020W	SOIC	W	16	1000	330	16.4	10.90	10.70	3.20	12.00	16.00	Q1
CA-IS3021W	SOIC	W	16	1000	330	16.4	10.90	10.70	3.20	12.00	16.00	Q1

14. Important statement

The above information is for reference only and used for helping Chipanalog customers with design, research and development. Chipanalog reserves the rights to change the above information due to technological innovation without advance notice.

All Chipanalog products pass ex-factory test. As for specific practical applications, customers need to be responsible for evaluating and determining whether the products are applicable or not by themselves. Chipanalog's authorization for customers to use the resources are only limited to development of the related applications of the Chipanalog products. In addition to this, the resources cannot be copied or shown, and Chipanalog is not responsible for any claims, compensations, costs, losses, liabilities and the like arising from the use of the resources.

Trademark information

Chipanalog Inc.® and Chipanalog® are registered trademarks of Chipanalog.



<http://www.chipanalog.com>