

CA-IS372x High-Speed Dual-Channel Digital Isolators

1. Features

- **Data rate: DC to 150Mbps**
- **Robust isolation barrier**
 - High lifetime: >40 years
 - Up to 5000 V_{RMS} isolation rating (Wide body packages)
 - ±150 kV/μs typical CMTI
- **Wide supply range: 2.5V to 5.5V**
- **Wide operating temperature range: -40°C to 125°C**
- **No start-up initialization required**
- **Default output *High* (CA-IS372xH) and *Low* (CA-IS372xL) Options**
- **High electromagnetic immunity**
- **Low power consumption**
 - 1.5mA per channel at 1Mbps with V_{DD} = 5.0V
 - 6.6mA per channel at 100Mbps with V_{DD} = 5.0V
- **Best in class propagation delay and skew**
 - 12ns typical propagation delay
 - 2ns propagation delay skew (chip -to-chip)
 - 1ns pulse width distortion
 - 5ns minimum pulse width
- **Schmitt trigger inputs**
- **Package options**
 - Narrow-body SOIC8(S) package
 - Wide-body SOIC8(G) package
 - Wide-body SOIC16(W) package
- **Safety regulatory approvals**
 - VDE 0884-17 isolation certification
 - UL according to UL1577
 - IEC 61010-1 and GB 4943.1-2022 certifications

2. Applications

- Industrial Automation
- Motor Control
- Medical Systems
- Isolated Power Supplies
- Solar Inverters
- Isolated RS485, CAN, RS232 etc.

3. General Description

The CA-IS372x devices are high-performance dual -channel digital isolators with up to 3.75kV_{RMS} (narrow-body package) and 5kV_{RMS} (wide-body package) isolation rating and ultra-fast data rate. The CA-IS372x devices provide high electromagnetic immunity and low emissions at low power consumption, while isolating CMOS digital I/O. Each isolation channel has a logic input and output buffer separated by capacitive silicon dioxide (SiO₂) insulation barrier, and each channel input integrated Schmitt trigger to provide excellent noise immunity.

The CA-IS3720 features two channels transferring digital signals in one direction for applications such as isolated digital I/O. The CA-IS3721/CA-IS3722 devices have 2 channels with 1 channel in each direction, making them ideal for isolating the Tx and Rx lines of a transceiver, such as RS485, CAN etc. communication. When the input is either not powered or is open-circuit, the default output is low for devices with suffix L and high for devices with suffix H.

The CA-IS372x family are specified over the -40°C to +125°C operating temperature range and are available in 8-pin SOIC narrow body package, 8-pin SOIC wide body package and 16-pin SOIC wide body package.

Device information

Part number	Package	Package size (NOM)
CA-IS3720 CA-IS3721 CA-IS3722	SOIC8-NB (S)	4.90 mm × 3.90 mm
	SOIC8-WB(G)	5.85 mm × 7.50 mm
	SOIC16-WB(W)	10.30mm × 7.50 mm

Simplified Channel Structure

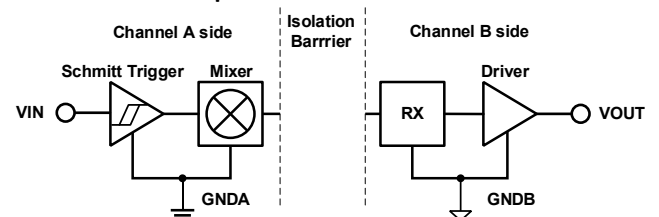

GNDA and GNDB are the isolated grounds for A side and B side respectively.

4. Ordering Information

Table 4-1. Ordering Information

Part Number	Number of Inputs A Side	Number of Inputs B Side	Default Output	Isolation Rating (kV _{RMS})	Output Enable	Package
CA-IS3720LS	2	0	Low	3.75	N/A	SOIC8-NB
CA-IS3720LG	2	0	Low	5.0	N/A	SOIC8-WB
CA-IS3720LW	2	0	Low	5.0	N/A	SOIC16-WB
CA-IS3720HS	2	0	High	3.75	N/A	SOIC8-NB
CA-IS3720HG	2	0	High	5.0	N/A	SOIC8-WB
CA-IS3720HW	2	0	High	5.0	N/A	SOIC16-WB
CA-IS3721LS	1	1	Low	3.75	N/A	SOIC8-NB
CA-IS3721LG	1	1	Low	5.0	N/A	SOIC8-WB
CA-IS3721LW	1	1	Low	5.0	N/A	SOIC16-WB
CA-IS3721HS	1	1	High	3.75	N/A	SOIC8-NB
CA-IS3721HG	1	1	High	5.0	N/A	SOIC8-WB
CA-IS3721HW	1	1	High	5.0	N/A	SOIC16-WB
CA-IS3722LS	1	1	Low	3.75	N/A	SOIC8-NB
CA-IS3722LG	1	1	Low	5.0	N/A	SOIC8-WB
CA-IS3722LW	1	1	Low	5.0	N/A	SOIC16-WB
CA-IS3722HS	1	1	High	3.75	N/A	SOIC8-NB
CA-IS3722HG	1	1	High	5.0	N/A	SOIC8-WB
CA-IS3722HW	1	1	High	5.0	N/A	SOIC16-WB

Contents

1. Features	1	7.9.2. $V_{DDA} = V_{DDB} = 3.3 V \pm 10\%$, $T_A = -40$ to 125°C	12
2. Applications	1	7.9.3. $V_{DDA} = V_{DDB} = 2.5 V \pm 5\%$, $T_A = -40$ to 125°C	13
3. General Description	1	7.10. Timing Characteristics.....	14
4. Ordering Information	2	7.10.1. $V_{DDA} = V_{DDB} = 5 V \pm 10\%$, $T_A = -40$ to 125°C	14
5. Revision History	3	7.10.2. $V_{DDA} = V_{DDB} = 3.3V \pm 10\%$, $T_A = -40$ to 125°C ...	14
6. Pin Configuration and Functions	4	7.10.3. $V_{DDA} = V_{DDB} = 2.5V \pm 5\%$, $T_A = -40$ to 125°C	14
7. Specifications	6	8. Parameter Measurement Information	15
7.1. Absolute Maximum Ratings ¹	6	9. Detailed Description	17
7.2. ESD Ratings.....	6	9.1. Overview.....	17
7.3. Recommended Operating Conditions.....	6	9.2. Functional Block Diagram	17
7.4. Thermal Information	7	9.3. Device Operation Modes	18
7.5. Power Ratings.....	7	10. Application and Implementation	19
7.6. Insulation Specifications.....	8	11. Package Information	20
7.7. Safety-Related Certifications	9	11.1. 8-Pin SOIC Package Outline.....	20
7.8. Electrical Characteristics	10	11.2. 8-Pin Wide Body SOIC Package Outline	20
7.8.1. $V_{DDA} = V_{DDB} = 5 V \pm 10\%$, $T_A = -40$ to 125°C	10	11.3. 16-Pin Wide Body SOIC Package Outline	22
7.8.2. $V_{DDA} = V_{DDB} = 3.3 V \pm 10\%$, $T_A = -40$ to 125°C	10	12. Soldering Temperature (reflow) Profile	23
7.8.3. $V_{DDA} = V_{DDB} = 2.5 V \pm 5\%$, $T_A = -40$ to 125°C	10	13. Tape and Reel Information	24
7.9. Supply Current Characteristics	11	14. Important statement	25
7.9.1. $V_{DDA} = V_{DDB} = 5 V \pm 10\%$, $T_A = -40$ to 125°C	11		

5. Revision History

Revision Number	Description	Revision Date	Page Changed
Version 1.0	N/A		N/A
Version 1.01	Changed V_{IORM} to 1414V, changed V_{IOWM} AC RMS value to 1000V and DC value to 1414V. Updated Power Ratings table.		8,11, 12, 13
Version 1.02	Changed $V_{IT+(IN)}$ minimum value to 2.0V, changed $V_{IT-(IN)}$ maximum value to 0.8V; removed $V_{I(HYS)}$.		10
Version 1.03	Changed the description of $V_{IT+(IN)}$ to logic input high level threshold, changed $V_{IT-(IN)}$ to logic input low level threshold		10
Version 1.04	Changed POD and tape reel information	2022/12/15	20,21,22,24
Version 1.05	Updated VDE Certification information	2023/09/01	9
Version 1.06	Updated CQC, TUV and UL certification information	2024.04.01	9

6. Pin Configuration and Functions

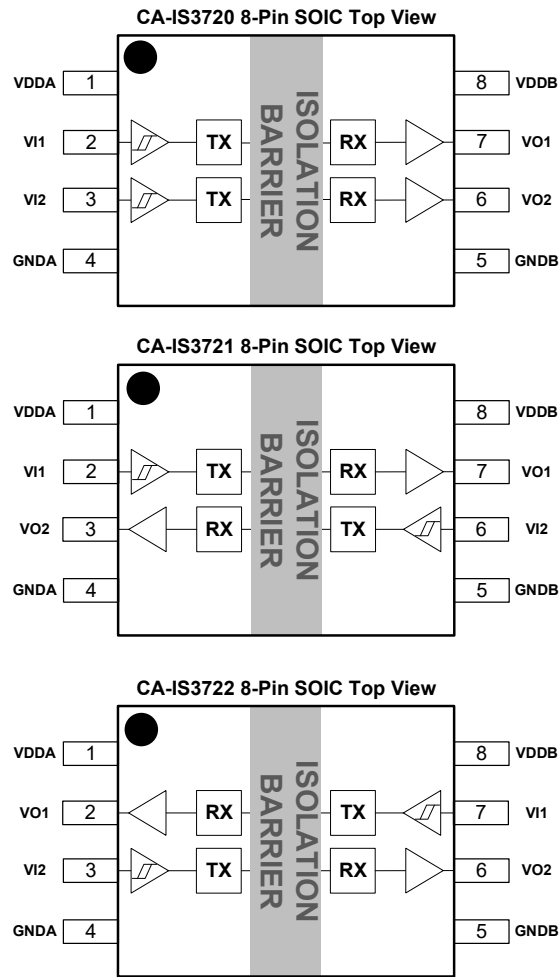

Figure 6-1. CA-IS372x 8-Pin SOIC Narrow body and 8-Pin Wide body SOIC Packages Top View

Table 6-1. Pin description for the CA-IS372x 8-Pin SOIC Narrow body and 8-Pin Wide body SOIC packages

SOIC8 Pin#			Name	Type	Description
CA-IS3720	CA-IS3721	CA-IS3722			
1	1	1	VDDA	Supply	Power supply for side A.
2	2	7	VI1	Digital I/O	Digital input 1 on side A/B, corresponds to logic output 1 on side B/A.
3	6	3	VI2	Digital I/O	Digital input 2 on side A/B, corresponds to logic output 2 on side B/A.
4	4	4	GNDA	Ground	Ground reference for side A.
5	5	5	GNDB	Ground	Ground reference for side B.
7	7	2	VO1	Digital I/O	Digital output 1 on side B/A, VO1 is the logic output for the VI1 input on side A/B.
6	3	6	VO2	Digital I/O	Digital output 2 on side B/A, VO2 is the logic output for the VI2 input on side A/B.
8	8	8	VDDB	Supply	Power supply for Side B.

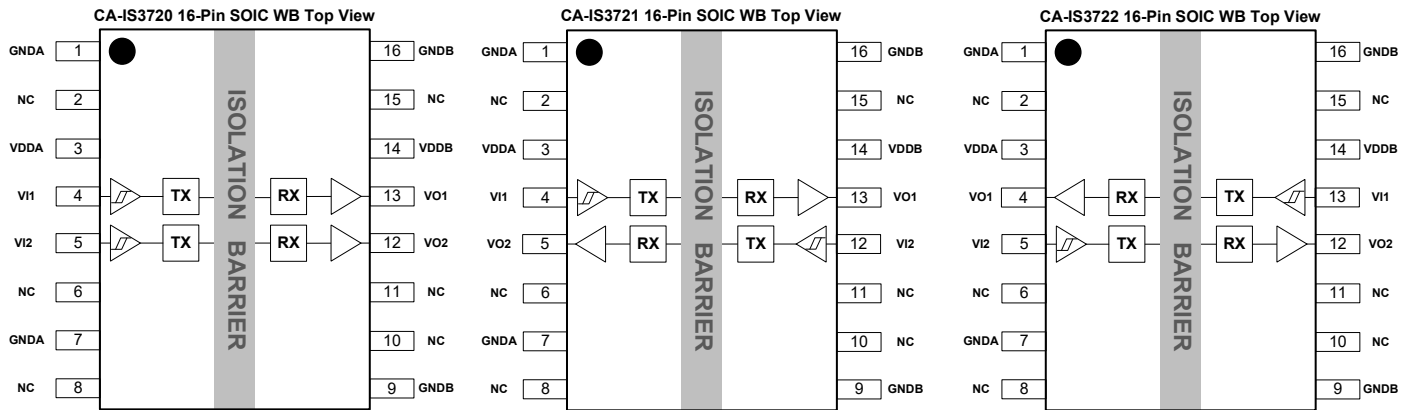

Figure 6-2. CA-IS372x 16-Pin SOIC Wide Body Package Top View

Table 6-2. Pin Description for the CA-IS372x 16-Pin SOIC Wide body package

SOIC-16 Pin#			Name	Type	Description
CA-IS3720	CA-IS3721	CA-IS3722			
1, 7	1, 7	1, 7	GNDA	Ground	Ground reference for side A.
2, 6, 8	2, 6, 8	2, 6, 8	NC ¹	No Connect	Not internally connected. They can be left floating, tied to VDDA or tied to GNDA.
3	3	3	VDDA	Supply	Power supply for side A.
4	4	13	VI1	Digital I/O	Digital input 1 on side A/B, corresponds to logic output 1 on side B/A.
5	12	5	VI2	Digital I/O	Digital input 2 on side A/B, corresponds to logic output 2 on side B/A.
10, 11, 15	10, 11, 15	10, 11, 15	NC ¹	No Connect	Not internally connected. They can be left floating, tied to VDDB or tied to GNDB.
9, 16	9, 16	9, 16	GNDB	Ground	Ground reference for side B.
13	13	4	VO1	Digital I/O	Digital output 1 on side B/A, VO1 is the logic output for the VI1 input on side A/B.
12	5	12	VO2	Digital I/O	Digital output 2 on side B/A, VO2 is the logic output for the VI2 input on side A/B.
14	14	14	VDDB	Supply	Power supply for side B.

Note:
1. No Connection. These pins are not internally connected. They can be left floating, tied to VDD_ or tied to GND_.

7. Specifications
7.1. Absolute Maximum Ratings¹

Parameters	Minimum value	Maximum value	Unit
V_{DDA}, V_{DDB} Power supply voltage ²	-0.5	7.0	V
V_{IN} Voltage at V_{Ix}, VOx, ENx	-0.5	$V_{DD-} + 0.5^3$	V
I_O Output current	-20	20	mA
T_J Operating Junction temperature		150	°C
T_{STG} Storage temperature range	-65	150	°C

Notes:

- The stresses listed under “Absolute Maximum Ratings” are stress ratings only, not for functional operation condition. Exposure to absolute maximum rating conditions for extended periods may cause permanent damage to the device.
- All voltage values are with respect to the local ground terminal (GNDA or GNDB) and are peak voltage values.
- Maximum voltage must not be exceed 7 V.

7.2. ESD Ratings

	Numerical value	Unit
V_{ESD} Electrostatic discharge		
Human body model (HBM), per ANSI/ESDA/JEDEC JS-001, all pins ¹	±6000	V
Charged device model (CDM), per JEDEC Specification JESD22-C101, all pins ²	±2000	

Notes:

- Per JEDEC document JEP155, 500V HBM allows safe manufacturing of standard ESD control process.
- Per JEDEC document JEP157, 250V HBM allows safe manufacturing of standard ESD control process.

7.3. Recommended Operating Conditions

Parameters	Minimum value	Typical value	Maximum value	Unit
V_{DDA}, V_{DDB} Supply Voltage	2.375	3.3	5.5	V
$V_{DD} <UVLO>$ V_{DD} Undervoltage-Lockout Threshold When Supply Voltage is Rising	1.95	2.24	2.375	V
$V_{DD} <UVLO>$ V_{DD} Undervoltage-Lockout Threshold When Supply Voltage is Falling	1.88	2.10	2.325	V
$V_{HYS} <UVLO>$ V_{DD} Undervoltage-Lockout Threshold Hysteresis	70	140	250	mV
I_{OH} High-level Output Current	$V_{DDO}^1 = 5V$	-4		mA
	$V_{DDO} = 3.3V$	-2		
	$V_{DDO} = 2.5V$	-1		
I_{OL} Low-level Output Current	$V_{DDO} = 5V$		4	mA
	$V_{DDO} = 3.3V$		2	
	$V_{DDO} = 2.5V$		1	
V_{IH} High-level Input Voltage	2.0			V
V_{IL} Low-level Input Voltage			0.8	V
DR Data Rate	0		150	Mbps
TA Ambient Temperature	-40	27	125	°C

Note:

- V_{DDO} = Output-side supply V_{DD} .

7.4. Thermal Information

Thermal Metric	CA-IS372x			Unit
	SOIC8	SOIC8-WB(G)	SOIC16-WB(W)	
R _{θJA} Junction-to-ambient thermal resistance	109.0	92.3	83.4	°C/W

7.5. Power Ratings

Parameters	Test Conditions	Minimum value	Typical value	Maximum value	Unit
CA-IS3720					
P _D Maximum Power Dissipation	V _{DDA} = V _{ddb} = 5.5 V, C _L = 15 pF, T _J = 150°C, Input a 75-MHz 50% duty cycle square wave			120	mW
P _{DA} Maximum Power Dissipation on Side-A				20	mW
P _{DB} Maximum Power Dissipation on Side-B				100	mW
CA-IS3721					
P _D Maximum Power Dissipation	V _{DDA} = V _{ddb} = 5.5 V, C _L = 15 pF, T _J = 150°C, Input a 75-MHz 50% duty cycle square wave			120	mW
P _{DA} Maximum Power Dissipation on Side-A				60	mW
P _{DB} Maximum Power Dissipation on Side-B				60	mW
CA-IS3722					
P _D Maximum Power Dissipation	V _{DDA} = V _{ddb} = 5.5 V, C _L = 15 pF, T _J = 150°C, Input a 75-MHz 50% duty cycle square wave			120	mW
P _{DA} Maximum Power Dissipation on Side-A				60	mW
P _{DB} Maximum Power Dissipation on Side-B				60	mW

7.6. Insulation Specifications

Parameters		Test Conditions	Value		Unit
			G/W	S	
CLR	External clearance	Shortest terminal-to-terminal distance through air	8	4	mm
CPG	External creepage	Shortest terminal-to-terminal distance across the package surface	8	4	mm
DTI	Distance through the insulation	Minimum internal gap (internal clearance)	28	28	μm
CTI	Comparative tracking index	DIN EN 60112 (VDE 0303-11); IEC 60112	>600	>600	V
	Material group	According to IEC 60664-1	I	I	
	Overvoltage category per IEC 60664-1	Rated mains voltage ≤ 150 V _{RMS}	I-IV	I-IV	
		Rated mains voltage ≤ 300 V _{RMS}	I-IV	I-III	
		Rated mains voltage ≤ 600 V _{RMS}	I-IV	n/a	
		Rated mains voltage ≤ 1000 V _{RMS}	I-III	n/a	
DIN V VDE V 0884-17:2021-10¹					
V _{IORM}	Maximum repetitive peak isolation voltage	AC voltage (bipolar)	1414	566	V _{PK}
V _{IOWM}	Maximum working isolation voltage	AC voltage; Time dependent dielectric breakdown (TDDb) Test	1000	400	V _{RMS}
		DC voltage	1414	566	V _{DC}
V _{IOTM}	Maximum transient isolation voltage	V _{TEST} = V _{IOTM} , t = 60 s (qualification); V _{TEST} = 1.2 × V _{IOTM} , t = 1 s (100% production)	7070	5300	V _{PK}
V _{IOSM}	Maximum surge isolation voltage ²	Test method per IEC 62368-1, 1.2/50 μs waveform, V _{TEST} = 1.6 × V _{IOSM} (qualification) (G/W) V _{TEST} = 1.3 × V _{IOSM} (qualification) (S)	7070	5000	V _{PK}
q _{pd}	Apparent charge ³	Method a, After Input-Output safety test subgroup 2/3, V _{ini} = V _{IOTM} , t _{ini} = 60 s; V _{pd(m)} = 1.2 × V _{IORM} , t _m = 10 s	≤5	≤5	pC
		Method a, After environmental tests subgroup 1, V _{ini} = V _{IOTM} , t _{ini} = 60 s; V _{pd(m)} = 1.6 × V _{IORM} , t _m = 10 s	≤5	≤5	
		Method b, At routine test (100% production) and preconditioning (type test) V _{ini} = 1.2 × V _{IOTM} , t _{ini} = 1 s; V _{pd(m)} = 1.875 × V _{IORM} , t _m = 1 s (W/G) V _{pd(m)} = 1.5 × V _{IORM} , t _m = 1 s (S)	≤5	≤5	
C _{IO}	Barrier capacitance, input to output ⁴	V _{IO} = 0.4 × sin(2πft), f = 1 MHz	~0.5	~0.5	pF
R _{IO}	Isolation resistance ⁴	V _{IO} = 500 V, T _A = 25°C	>10 ¹²	>10 ¹²	Ω
		V _{IO} = 500 V, 100°C ≤ T _A ≤ 125°C	>10 ¹¹	>10 ¹¹	
		V _{IO} = 500 V at T _S = 150°C	>10 ⁹	>10 ⁹	
	Pollution degree		2	2	
UL 1577					
V _{ISO}	Maximum withstanding isolation voltage	V _{TEST} = V _{ISO} , t = 60 s (qualification), V _{TEST} = 1.2 × V _{ISO} , t = 1 s (100% production test)	5000	3750	V _{RMS}
Notes:					
1. This coupler is suitable for “safe electrical insulation” only within the safety ratings. Compliance with the safety ratings shall be ensured by means of suitable protective circuits.					
2. Devices are immersed in oil during surge characterization.					
3. The characterization charge is discharging charge (pd) caused by partial discharge.					
4. Capacitance and resistance are measured with all pins on field-side and logic-side tied together.					

7.7. Safety-Related Certifications

VDE	UL	CQC	TUV
Certified according to DIN EN IEC 60747-17 (VDE 0884-17):2021-10; EN IEC 60747-17:2020+AC:2021	Certified according to UL 1577 Component Recognition Program	Certified according to GB 4943.1-2022	Certified according to EN 61010-1:2010+A1
Maximum transient isolation voltage: 7070V _{pk} (SOIC16-WB, SOIC8-WB) and 5300V _{pk} (SOIC8-NB) Maximum repetitive peak isolation voltage: 1414V _{pk} (SOIC16-WB, SOIC8-WB) and 566V _{pk} (SOIC8-NB) Maximum surge isolation voltage: 7070V _{pk} (SOIC16-WB, SOIC8-WB) and 5000V _{pk} (SOIC8-NB)	SOIC8-NB: 3750 V _{RMS} ; SOIC8-WB: 5000 V _{RMS} ; SOIC16-WB: 5000 V _{RMS}	SOIC8-WB: Reinforced insulation SOIC16-WB: Reinforced insulation (Altitude ≤ 5000 m)	5000 V _{RMS} (SOIC8-WB / SOIC16-WB) insulation and 3750 V _{RMS} (SOIC8-NB) insulation per EN/IEC 61010-1:2010+A1
Certificate number: 40057278 Certificate number: 40052786	Certificate number: E511334	Certificate number: SOIC16-WB:CQC23001406424 SOIC8-WB:CQC24001434134	Certificate number: AK 505918190001

7.8. Electrical Characteristics
7.8.1. $V_{DDA} = V_{DDB} = 5\text{ V} \pm 10\%$, $T_A = -40$ to 125°C

PARAMETER	TEST CONDITIONS	MIN	TYPE	MAX	UNIT
V_{OH}	High-level Output Voltage $I_{OH} = -4\text{mA}$; See Figure 8-1	$V_{DDO}^{1-0.4}$	4.8		V
V_{OL}	Low-level Output Voltage $I_{OL} = 4\text{mA}$; See Figure 8-1		0.2	0.4	V
$V_{IT+(IN)}$	Logic input high level threshold	2.0			V
$V_{IT-(IN)}$	Logic input low level threshold			0.8	V
I_{IH}	High-Level Input Leakage Current $V_{IH} = V_{DDA}$ at INx or ENx			20	μA
I_{IL}	Low-Level Input Leakage Current $V_{IL} = 0\text{ V}$ at INx	-20			μA
Z_O	Output Impedance ²		50		Ω
CMTI	Common-mode Transient Immunity $V_I = V_{DDI}^{1}$ or 0 V , $V_{CM} = 1200\text{ V}$; See Figure 8-3	100	150		$\text{kV}/\mu\text{s}$
C_i	Input Capacitance ³ $V_I = V_{DD}/2 + 0.4 \times \sin(2\pi ft)$, $f = 1\text{ MHz}$, $V_{DD} = 5\text{ V}$		2		pF

Notes:

- V_{DDI} = Input-side VDD supply voltage, V_{DDO} = Output-side VDD supply voltage.
- The nominal output impedance of each isolator driver is $50\ \Omega \pm 40\%$.
- Measured from pin to Ground.

7.8.2. $V_{DDA} = V_{DDB} = 3.3\text{ V} \pm 10\%$, $T_A = -40$ to 125°C

PARAMETER	TEST CONDITIONS	MIN	TYPE	MAX	UNIT
V_{OH}	High-level Output Voltage $I_{OH} = -2\text{mA}$; See Figure 8-1	$V_{DDO}^{1-0.4}$	3.1		V
V_{OL}	Low-level Output Voltage $I_{OL} = 2\text{mA}$; See Figure 8-1		0.2	0.4	V
$V_{IT+(IN)}$	Logic input high level threshold	2.0			V
$V_{IT-(IN)}$	Logic input low level threshold			0.8	V
I_{IH}	High-Level Input Leakage Current $V_{IH} = V_{DDA}$ at Ax or Bx or ENx			20	μA
I_{IL}	Low-Level Input Leakage Current $V_{IL} = 0\text{ V}$ at Ax or Bx	-20			μA
Z_O	Output Impedance ²		50		Ω
CMTI	Common-mode Transient Immunity $V_I = V_{DDI}^{1}$ or 0 V , $V_{CM} = 1200\text{ V}$; See Figure 8-3	100	150		$\text{kV}/\mu\text{s}$
C_i	Input Capacitance ³ $V_I = V_{DD}/2 + 0.4 \times \sin(2\pi ft)$, $f = 1\text{ MHz}$, $V_{DD} = 3.3\text{ V}$		2		pF

Notes:

- V_{DDI} = Input-side VDD supply voltage, V_{DDO} = Output-side VDD supply voltage.
- The nominal output impedance of each isolator driver is $50\ \Omega \pm 40\%$.
- Measured from pin to Ground.

7.8.3. $V_{DDA} = V_{DDB} = 2.5\text{ V} \pm 5\%$, $T_A = -40$ to 125°C

PARAMETER	TEST CONDITIONS	MIN	TYPE	MAX	UNIT
V_{OH}	High-level Output Voltage $I_{OH} = -1\text{mA}$; See Figure 8-1	$V_{DDO}^{1-0.4}$	2.3		V
V_{OL}	Low-level Output Voltage $I_{OL} = 1\text{mA}$; See Figure 8-1		0.2	0.4	V
$V_{IT+(IN)}$	Logic input high level threshold			2.0	V
$V_{IT-(IN)}$	Logic input low level threshold	0.8			V
I_{IH}	High-Level Input Leakage Current $V_{IH} = V_{DDA}$ at Ax or Bx or ENx			20	μA
I_{IL}	Low-Level Input Leakage Current $V_{IL} = 0\text{ V}$ at Ax or Bx	-20			μA
Z_O	Output Impedance ²		50		Ω
CMTI	Common-mode Transient Immunity $V_I = V_{DDI}^{1}$ or 0 V , $V_{CM} = 1200\text{ V}$; See Figure 8-3	100	150		$\text{kV}/\mu\text{s}$
C_i	Input Capacitance ³ $V_I = V_{DD}/2 + 0.4 \times \sin(2\pi ft)$, $f = 1\text{ MHz}$, $V_{DD} = 3.3\text{ V}$		2		pF

Notes:

- V_{DDI} = Input-side VDD supply voltage, V_{DDO} = Output-side VDD supply voltage.
- The nominal output impedance of each isolator driver is $50\ \Omega \pm 40\%$.
- Measured from pin to Ground.

Shanghai Chipanalog Microelectronics Co., Ltd.

7.9. Supply Current Characteristics

7.9.1. $V_{DDA} = V_{ddb} = 5 V \pm 10\%$, $T_A = -40$ to $125^\circ C$

PARAMETER	TEST CONDITIONS	SUPPLY CURRENT	MIN	TYP	MAX	UNIT	
CA-IS3720							
Supply Current – DC Signal	$V_{IN} = 0V$ (CA-IS3720L); $V_{IN} = V_{DDI}^1$ (CA-IS3720H)	I_{DDA}		0.9	1.3	mA	
		I_{ddb}		1.4	2.2		
	$V_{IN} = V_{DDI}$ (CA-IS3720L); $V_{IN} = 0V$ (CA-IS3720H)	I_{DDA}		2.5	4.1		
		I_{ddb}		1.5	2.3		
Supply Current – AC Signal	All Channels Switching with 5V, 50% Duty Cycle Square Wave Clock Input; $C_L = 15$ pF for Each Channel.	1Mbps (500kHz)	I_{DDA}		1.7		2.7
			I_{ddb}		2.2		3.2
		10Mbps (5MHz)	I_{DDA}		1.8		2.9
			I_{ddb}		8.8		11.8
		100Mbps (50MHz)	I_{DDA}		2.5	3.9	
			I_{ddb}		22	30.0	
CA-IS3721							
Supply Current – DC Signal	$V_{IN} = 0V$ (CA-IS3721L); $V_{IN} = V_{DDI}$ (CA-IS3721H)	I_{DDA}		1.6	3.2	mA	
		I_{ddb}		1.6	3.2		
	$V_{IN} = V_{DDI}$ (CA-IS3721L); $V_{IN} = 0V$ (CA-IS3721H)	I_{DDA}		2.9	5.8		
		I_{ddb}		2.9	5.8		
Supply Current – AC Signal	All Channels Switching with 5V, 50% Duty Cycle Square Wave Clock Input; $C_L = 15$ pF for Each Channel.	1Mbps (500kHz)	I_{DDA}		2.1		3.2
			I_{ddb}		2.1		3.2
		10Mbps (5MHz)	I_{DDA}		5.6		7.8
			I_{ddb}		5.6		7.8
		100Mbps (50MHz)	I_{DDA}		12.9	22	
			I_{ddb}		12.9	22	
CA-IS3722							
Supply Current – DC Signal	$V_{IN} = 0V$ (CA-IS3722L); $V_{IN} = V_{DDI}$ (CA-IS3722H)	I_{DDA}		1.6	3.2	mA	
		I_{ddb}		1.6	3.2		
	$V_{IN} = V_{DDI}$ (CA-IS3722L); $V_{IN} = 0V$ (CA-IS3722H)	I_{DDA}		2.9	5.8		
		I_{ddb}		2.9	5.8		
Supply Current – AC Signal	All Channels Switching with 5V, 50% Duty Cycle Square Wave Clock Input; $C_L = 15$ pF for Each Channel.	1Mbps (500kHz)	I_{DDA}		2.1		3.2
			I_{ddb}		2.1		3.2
		10Mbps (5MHz)	I_{DDA}		5.6		7.8
			I_{ddb}		5.6		7.8
		100Mbps (50MHz)	I_{DDA}		12.9	22	
			I_{ddb}		12.9	22	
Note:							
1. V_{DDI} = Input-side supply voltage V_{DD} .							

CA-IS3720, CA-IS3721, CA-IS3722

Version 1.06

Shanghai Chipanalog Microelectronics Co., Ltd.

7.9.2. $V_{DDA} = V_{ddb} = 3.3\text{ V} \pm 10\%$, $T_A = -40\text{ to }125^\circ\text{C}$

PARAMETER	TEST CONDITIONS	SUPPLY CURRENT	MIN	TYP	MAX	UNIT
CA-IS3720						
Supply Current – DC Signal	$V_{IN} = 0\text{V}$ (CA-IS3720L); $V_{IN} = V_{DDI}^1$ (CA-IS3720H)	I_{DDA}	0.8	1.3		mA
		I_{ddb}	1.3	2.0		
	$V_{IN} = V_{DDI}$ (CA-IS3720L); $V_{IN} = 0\text{V}$ (CA-IS3720H)	I_{DDA}	2.4	4.0		
		I_{ddb}	1.4	2.2		
Supply Current – AC Signal	All Channels Switching with 3.3V, 50% Duty Cycle Square Wave Clock Input; CL = 15 pF for Each Channel.	1Mbps (500kHz)	I_{DDA}	1.6	2.7	
			I_{ddb}	1.9	2.7	
		10Mbps (5MHz)	I_{DDA}	1.7	2.7	
			I_{ddb}	6.2	8.4	
		100Mbps (50MHz)	I_{DDA}	2.2	3.5	
			I_{ddb}	14.4	19.7	
CA-IS3721						
Supply Current – DC Signal	$V_{IN} = 0\text{V}$ (CA-IS3721L); $V_{IN} = V_{DDI}$ (CA-IS3721H)	I_{DDA}	1.2	1.9		mA
		I_{ddb}	1.2	1.9		
	$V_{IN} = V_{DDI}$ (CA-IS3721L); $V_{IN} = 0\text{V}$ (CA-IS3721H)	I_{DDA}	2.3	3.3		
		I_{ddb}	2.3	3.3		
Supply Current – AC Signal	All Channels Switching with 3.3V, 50% Duty Cycle Square Wave Clock Input; CL = 15 pF for Each Channel.	1Mbps (500kHz)	I_{DDA}	1.9	2.9	
			I_{ddb}	1.9	2.9	
		10Mbps (5MHz)	I_{DDA}	4.2	5.9	
			I_{ddb}	4.2	5.9	
		100Mbps (50MHz)	I_{DDA}	8.8	12.1	
			I_{ddb}	8.8	12.1	
CA-IS3722						
Supply Current – DC Signal	$V_{IN} = 0\text{V}$ (CA-IS3722L); $V_{IN} = V_{DDI}$ (CA-IS3722H)	I_{DDA}	1.2	1.9		mA
		I_{ddb}	1.2	1.9		
	$V_{IN} = V_{DDI}$ (CA-IS3722L); $V_{IN} = 0\text{V}$ (CA-IS3722H)	I_{DDA}	2.3	3.3		
		I_{ddb}	2.3	3.3		
Supply Current – AC Signal	All Channels Switching with 3.3V, 50% Duty Cycle Square Wave Clock Input; CL = 15 pF for Each Channel.	1Mbps (500kHz)	I_{DDA}	1.9	2.9	
			I_{ddb}	1.9	2.9	
		10Mbps (5MHz)	I_{DDA}	4.2	5.9	
			I_{ddb}	4.2	5.9	
		100Mbps (50MHz)	I_{DDA}	8.8	12.1	
			I_{ddb}	8.8	12.1	
Note:						
1. V_{DDI} = Input-side supply V_{DD} .						

Shanghai Chipanalog Microelectronics Co., Ltd.

7.9.3. $V_{DDA} = V_{ddb} = 2.5\text{ V} \pm 5\%$, $T_A = -40\text{ to }125^\circ\text{C}$

PARAMETER	TEST CONDITIONS	SUPPLY CURRENT	MIN	TYP	MAX	UNIT	
CA-IS3720							
Supply Current – DC Signal	$V_{IN} = 0\text{V}$ (CA-IS3720L); $V_{IN} = V_{DDI}^1$ (CA-IS3720H)	I_{DDA}		0.8	1.2	mA	
		I_{ddb}		1.4	2.0		
	$V_{IN} = V_{DDI}$ (CA-IS3720L); $V_{IN} = 0\text{V}$ (CA-IS3720H)	I_{DDA}		2.4	4.0		
		I_{ddb}		1.4	2.1		
Supply Current – AC Signal	All Channels Switching with 2.5V, 50% Duty Cycle Square Wave Clock Input; CL = 15 pF for Each Channel.	1Mbps (500kHz)	I_{DDA}		1.6		2.6
			I_{ddb}		1.7		2.5
		10Mbps (5MHz)	I_{DDA}		1.7		2.7
			I_{ddb}		5.0		6.8
		100Mbps (50MHz)	I_{DDA}		2.1	3.4	
			I_{ddb}		10.8	14.7	
CA-IS3721							
Supply Current – DC Signal	$V_{IN} = 0\text{V}$ (CA-IS3721L); $V_{IN} = V_{DDI}$ (CA-IS3721H)	I_{DDA}		1.5	1.9	mA	
		I_{ddb}		1.5	1.9		
	$V_{IN} = V_{DDI}$ (CA-IS3721L); $V_{IN} = 0\text{V}$ (CA-IS3721H)	I_{DDA}		2.1	3.1		
		I_{ddb}		2.1	3.1		
Supply Current – AC Signal	All Channels Switching with 2.5V, 50% Duty Cycle Square Wave Clock Input; CL = 15 pF for Each Channel.	1Mbps (500kHz)	I_{DDA}		1.9		2.8
			I_{ddb}		1.9		2.8
		10Mbps (5MHz)	I_{DDA}		3.6		5.2
			I_{ddb}		3.6		5.2
		100Mbps (50MHz)	I_{DDA}		6.9	9.5	
			I_{ddb}		6.9	9.5	
CA-IS3722							
Supply Current – DC Signal	$V_{IN} = 0\text{V}$ (CA-IS3722L); $V_{IN} = V_{DDI}$ (CA-IS3722H)	I_{DDA}		1.5	1.9	mA	
		I_{ddb}		1.5	1.9		
	$V_{IN} = V_{DDI}$ (CA-IS3722L); $V_{IN} = 0\text{V}$ (CA-IS3722H)	I_{DDA}		2.1	3.1		
		I_{ddb}		2.1	3.1		
Supply Current – AC Signal	All Channels Switching with 2.5V, 50% Duty Cycle Square Wave Clock Input; CL = 15 pF for Each Channel.	1Mbps (500kHz)	I_{DDA}		1.9		2.8
			I_{ddb}		1.9		2.8
		10Mbps (5MHz)	I_{DDA}		3.6		5.2
			I_{ddb}		3.6		5.2
		100Mbps (50MHz)	I_{DDA}		6.9	9.5	
			I_{ddb}		6.9	9.5	
Note:							
1. V_{DDI} = Input-side supply V_{DD} .							

7.10. Timing Characteristics
7.10.1. $V_{DDA} = V_{DDB} = 5V \pm 10\%$, $T_A = -40$ to 125°C

PARAMETER	TEST CONDITIONS	MIN	TYP	MAX	UNIT
DR Data Rate		0		150	Mbps
PW _{min} Minimum Pulse Width				5.0	ns
t _{PLH} , t _{PHL} Propagation Delay Time	See Figure 8-1	5.0	12.0	15.0	ns
PWD Pulse Width Distortion t _{PLH} - t _{PHL}					
t _{sk(o)} Channel-to-channel Output Skew Time ¹	Same-direction		0.4	2.5	ns
t _{sk(pp)} Chip -to-chip Output Skew Time ²			2.0	4.5	ns
t _r Output Signal Rise Time	See Figure 8-1		2.5	4.0	ns
t _f Output Signal Fall Time	See Figure 8-1		2.5	4.0	ns
t _{DO} Default Output Delay Time from Input Power Loss	See Figure 8-2		8	12	ns
t _{SU} Start-up Time			15	40	μs

Notes:

1. tsk(o) is the skew between outputs of a single device with all driving inputs connected together and the outputs switching in the same direction while driving identical loads.
2. tsk(pp) is the magnitude of the difference in propagation delay times between any terminals of different devices switching in the same direction while operating at identical supply voltages, temperature, input signals and loads.

7.10.2. $V_{DDA} = V_{DDB} = 3.3V \pm 10\%$, $T_A = -40$ to 125°C

PARAMETER	TEST CONDITIONS	MIN	TYP	MAX	UNIT
DR Data Rate		0		150	Mbps
PW _{min} Minimum Pulse Width				5.0	ns
t _{PLH} , t _{PHL} Propagation Delay Time	See Figure 8-1	5.0	12.0	15.0	ns
PWD Pulse Width Distortion t _{PLH} - t _{PHL}					
t _{sk(o)} Channel-to-channel Output Skew Time ¹	Same-direction		0.4	2.5	ns
t _{sk(pp)} Chip -to-chip Output Skew Time ²			2.0	4.5	ns
t _r Output Signal Rise Time	See Figure 8-1		2.5	4.0	ns
t _f Output Signal Fall Time	See Figure 8-1		2.5	4.0	ns
t _{DO} Default Output Delay Time from Input Power Loss	See Figure 8-2		8	12	ns
t _{SU} Start-up Time			15	40	μs

Notes:

1. tsk(o) is the skew between outputs of a single device with all driving inputs connected together and the outputs switching in the same direction while driving identical loads.
2. tsk(pp) is the magnitude of the difference in propagation delay times between any terminals of different devices switching in the same direction while operating at identical supply voltages, temperature, input signals and loads.

7.10.3. $V_{DDA} = V_{DDB} = 2.5V \pm 5\%$, $T_A = -40$ to 125°C

PARAMETER	TEST CONDITIONS	MIN	TYP	MAX	UNIT
DR Data Rate		0		150	Mbps
PW _{min} Minimum Pulse Width				5.0	ns
t _{PLH} , t _{PHL} Propagation Delay Time	See Figure 8-1	5.0	12.0	15.0	ns
PWD Pulse Width Distortion t _{PLH} - t _{PHL}					
t _{sk(o)} Channel-to-channel Output Skew Time ¹	Same-direction		0.4	2.5	ns
t _{sk(pp)} Chip -to-chip Output Skew Time ²			2.0	5.0	ns
t _r Output Signal Rise Time	See Figure 8-1		2.5	4.0	ns
t _f Output Signal Fall Time	See Figure 8-1		2.5	4.0	ns
t _{DO} Default Output Delay Time from Input Power Loss	See Figure 8-2		8	12	ns
t _{SU} Start-up Time			15	40	μs

Notes:

1. $t_{sk(o)}$ is the skew between outputs of a single device with all driving inputs connected together and the outputs switching in the same direction while driving identical loads.
2. $t_{sk(pp)}$ is the magnitude of the difference in propagation delay times between any terminals of different devices switching in the same direction while operating at identical supply voltages, temperature, input signals and loads.

8. Parameter Measurement Information

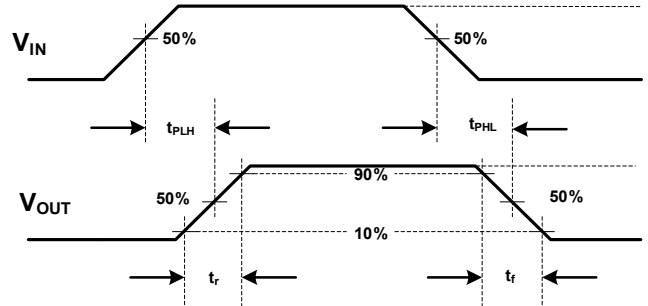
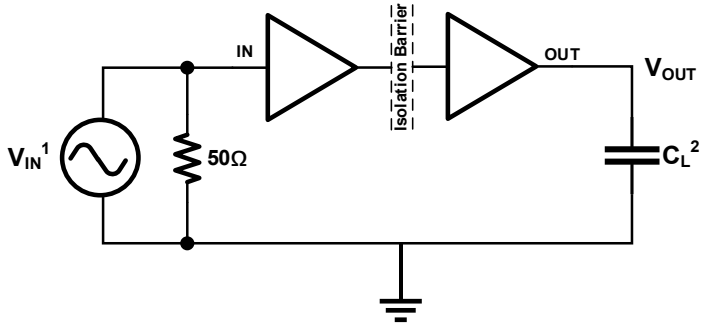

Notes:

1. A square wave generator provide V_{IN} input signal with characteristics: frequency $\leq 100\text{kHz}$, 50% duty cycle, $t_r \leq 3\text{ns}$, $t_f \leq 3\text{ns}$, $Z_{out} = 50\Omega$. At the input, 50Ω resistor is required to terminate input generator signal. It is not needed in actual application.
2. $C_L = 15\text{pF}$ and includes external circuit (instrumentation and fixture etc.) capacitance. Since the load capacitance influence the output rising time, it's a key factor in the timing characteristic measurement.

Figure 8-1. Switching Characteristics Test Circuit and Voltage Waveforms

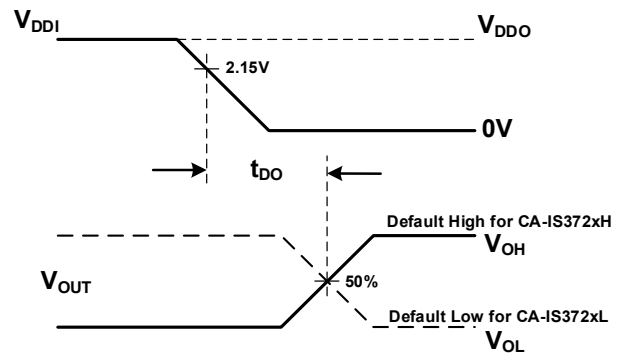
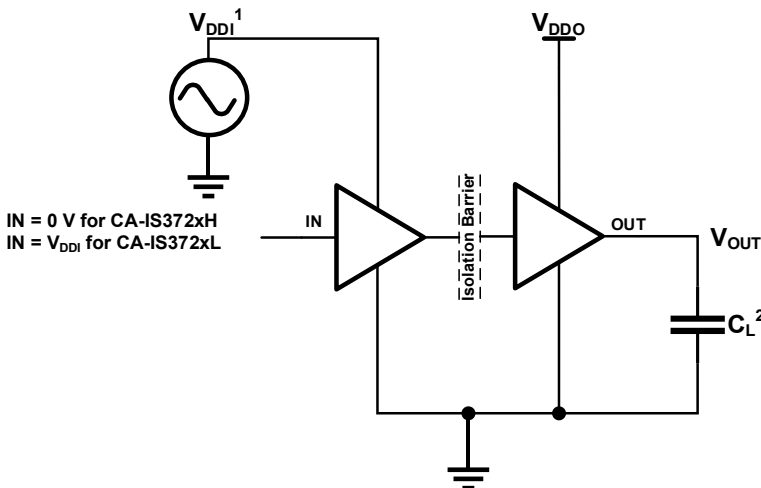

Notes:

1. Power Supply Ramp Rate = 10 mV/ns . V_{DD1} should be over 2.15V and less than 5.5V .
2. $C_L = 15\text{pF}$ and includes external circuit (instrumentation and fixture etc.) capacitance. Since the load capacitance influence the output rising time, it's a key factor in the timing characteristic measurement.

Figure 8-2. Default Output Delay Time Test Circuit and Voltage Waveforms

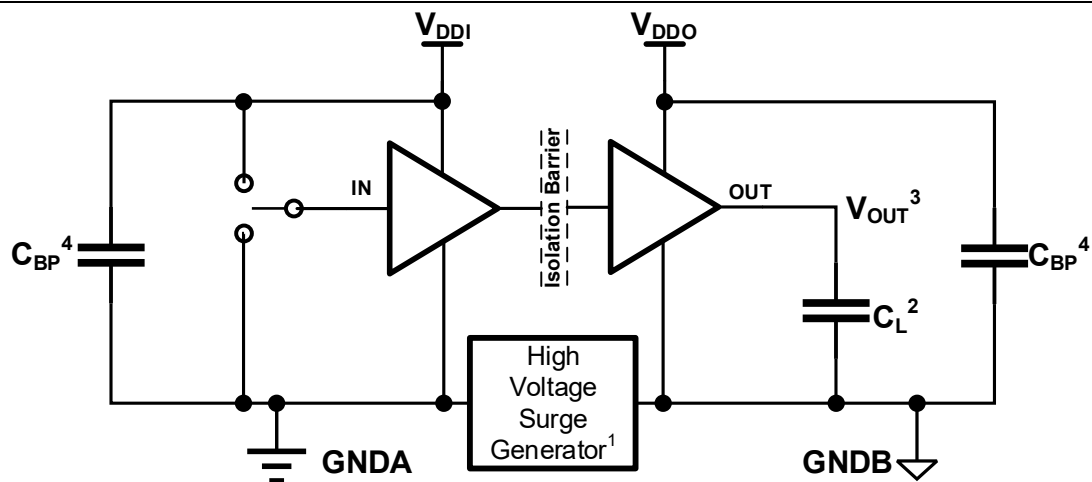

Notes:

1. The High Voltage Surge Generator generates repetitive surges with $> 1\text{kV}$, $< 10\text{ns}$ rise time and fall time to reach common-mode transient noise with $> 100\text{kV}/\mu\text{s}$ slew rate.
2. $C_L = 15\text{pF}$ and includes external circuit (instrumentation and fixture etc.) capacitance.
3. Pass-fail criteria: The output must remain stable whenever the high voltage surges occurs.
4. C_{BP} is bypass capacitor, $0.1\mu\text{F} \sim 1\mu\text{F}$.

Figure 8-3. Common-Mode Transient Immunity Test Circuit

9. Detailed Description

9.1. Overview

The CA-IS372x devices are a family of 2-channel digital galvanic isolators using Chipanalog’s full differential capacitive isolation technology. These devices have an ON-OFF keying (OOK) modulation scheme to transfer digital signals across the SiO₂ based isolation barrier between circuits with different power domains. The transmitter sends a high frequency carrier across the barrier to represent one digital state and sends no signal to represent the other digital state. The receiver demodulates the signal and recovery input signal at output through a buffer stage. With this OOK architecture, the CA-IS372x family of devices build a robust data transmission path between different power domains, without any special start-up initialization requirements.

These devices also incorporate advanced full differential techniques to maximize the CMTI performance and minimize the radiated emissions due the high frequency carrier and IO buffer switching. The conceptual block diagram of a digital capacitive isolator, Figure 9-1, shows a functional block diagram of a typical channel; Figure 9-2 shows the operating waveform of a typical channel.

9.2. Functional Block Diagram

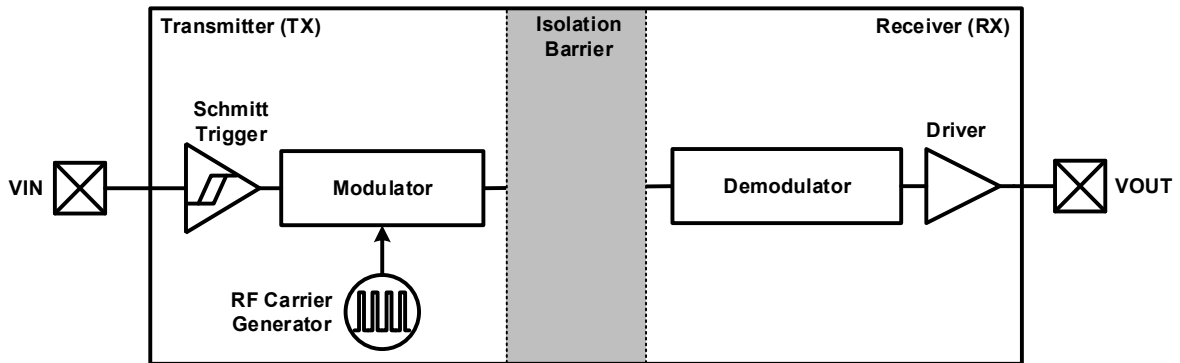

Figure 9-1. Functional Block Diagram of a Single Channel

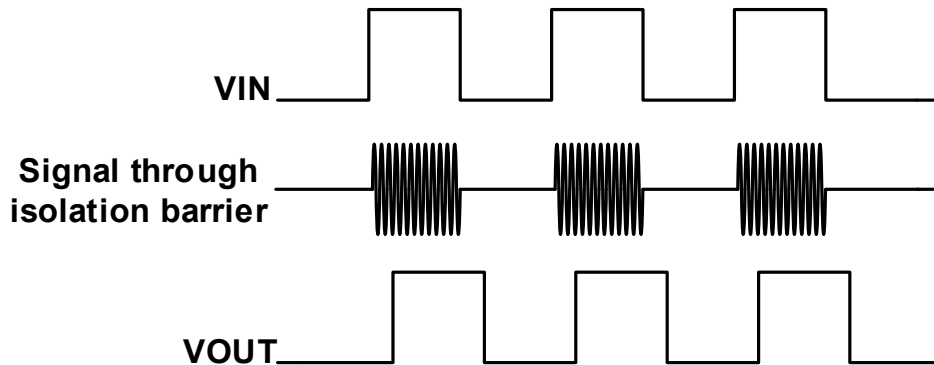

Figure 9-2. Conceptual Operation Waveform of a Single Channel

9.3. Device Operation Modes

Table 9-1 lists the operation modes for the CA-IS372x devices.

Table 9-1 Operation Mode Table

V_{DDI}^1	V_{DDO}	INPUT(Ax/Bx) ²	OUTPUT (Ax/Bx)	OPERATION
PU	PU	H	H	Normal operation mode: A channel output follows the logic state of the input.
		L	L	
		Open	Default	Default output, fail-safe mode: If a channel input is open, the corresponding channel output goes to the default logic state (Low for CA-IS372xL and High for CA-IS372xH)
PD	PU	X	Default	Default output, fail-safe mode: When V_{DDI} is unpowered, the corresponding channel output goes to the default logic state (Low for CA-IS372xL and High for CA-IS372xH)
X	PD	X	Undetermined	When V_{DDO} is unpowered, the output states are undetermined. ³

Notes:

- V_{DDI} = Input-side supply V_{DD} ; V_{DDO} = Output-side supply V_{DD} ; PU = Powered up ($V_{DD_} \geq V_{DD(UVLO+)}$); PD = Powered down ($V_{DD_} \leq V_{DD(UVLO-)}$); X = Irrelevant; H = High level; L = Low level.
- A strongly driven input signal can weakly power the floating VDD through an internal protection diode and cause undetermined output.
- The outputs are in undetermined state when $V_{DD(UVLO+)} < V_{DDI}$, $V_{DDO} < V_{DD(UVLO-)}$.

10. Application and Implementation

Unlike optocouplers, which require external components to improve performance, provide bias, or limit current, the CA-IS372x devices only require two external bypass capacitors to operate. To reduce ripple and the chance of introducing data errors, bypass VDDA and VDDB pins with 0.1μF to 1μF low-ESR ceramic capacitors to GNDA and GNDB, respectively. Place the bypass capacitors as close to the power supply input pins as possible. Figure 10-1 and Figure 10-2 show typical operating circuit of the CA-IS372x devices.

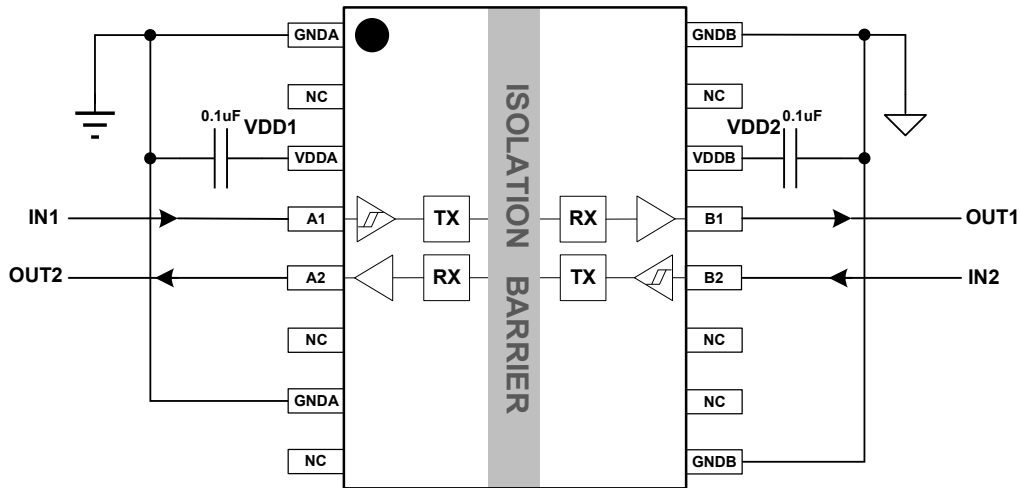

Figure 10-1. CA-IS3721 Typical Application Schematic

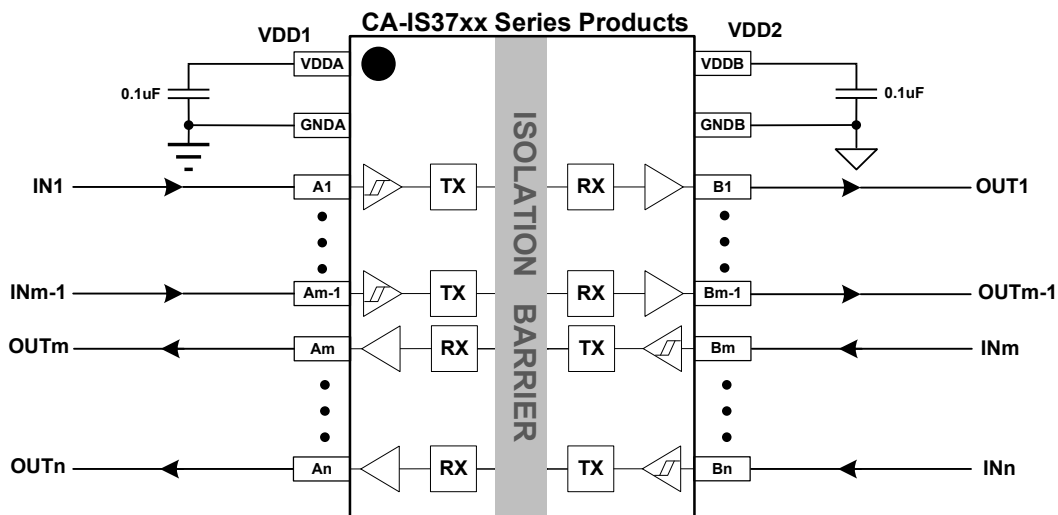
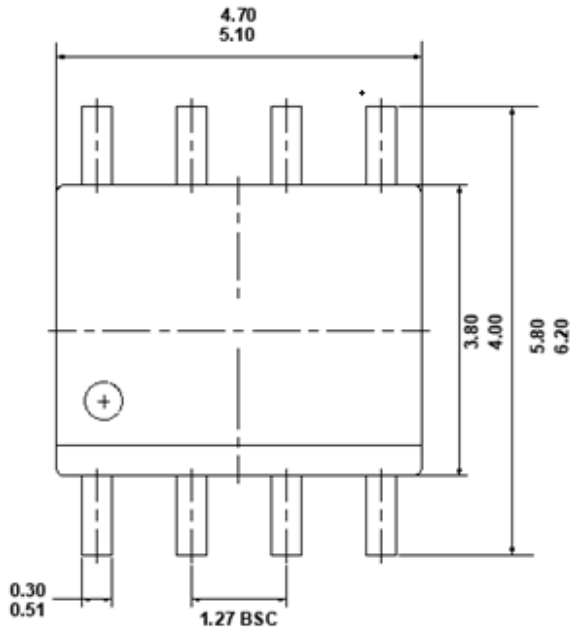
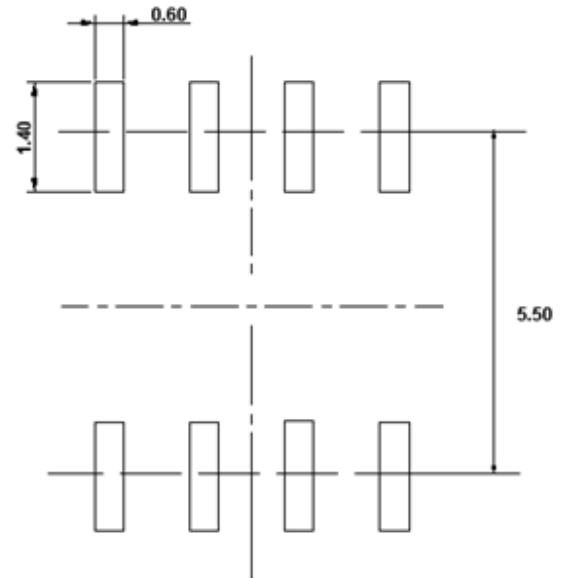
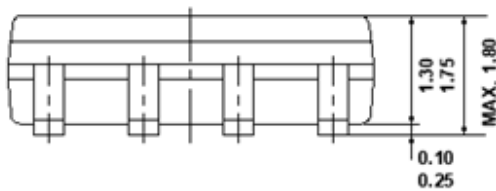
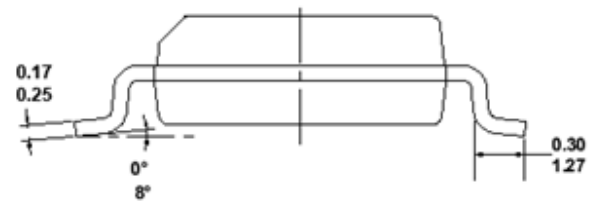

Figure 10-2. Typical Applications for the CA-IS37xx Series Digital Isolators

11. Package Information
11.1. 8-Pin SOIC Package Outline

These figures show the package details and the recommended land pattern details for the CA-IS372x digital isolator in 8-pin narrow-body SOIC package. The values for the dimensions are shown in millimeters.



TOP VIEW

RECOMMENDED LAND PATTERN

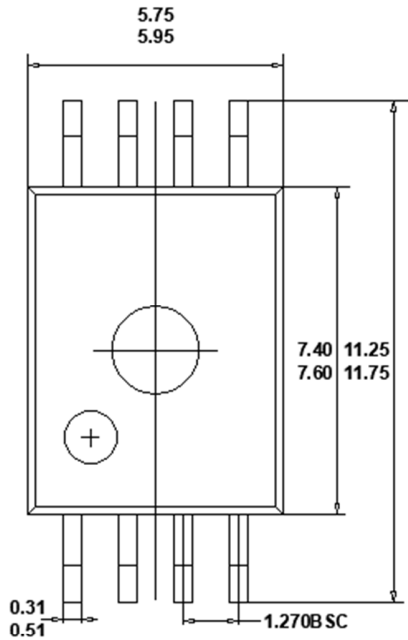
FRONT VIEW

LEFT SIDE VIEW

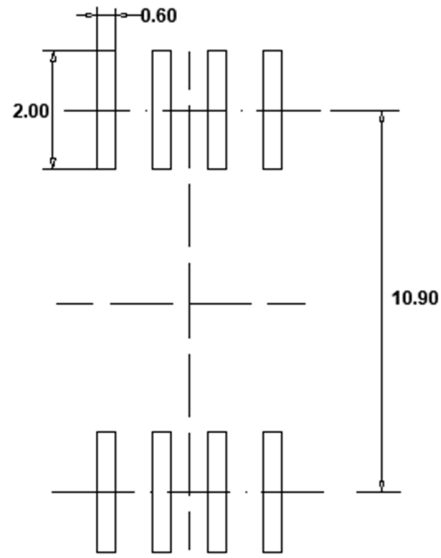
11.2. 8-Pin Wide Body SOIC Package Outline

These figures show the package details and the recommended land pattern details for the CA-IS372x digital isolator in 8-pin wide body SOIC package. The values for the dimensions are shown in millimeters.



TOP VIEW



RECOMMENDED LAND PATTERN

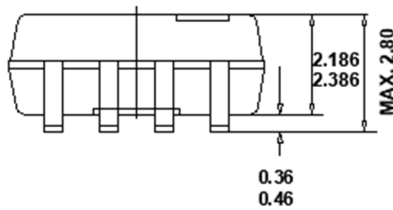

FRONT VIEW

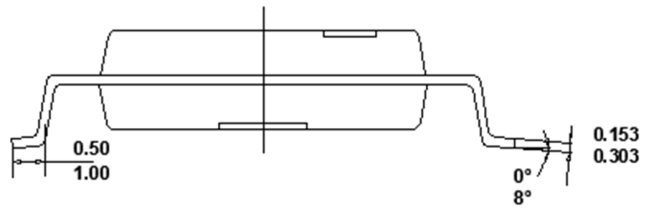

LEFT SIDE VIEW

CA-IS3720, CA-IS3721, CA-IS3722

Version 1.06

Shanghai Chipanalog Microelectronics Co., Ltd.

11.3. 16-Pin Wide Body SOIC Package Outline

These figures show the package details and the recommended land pattern details for the CA-IS372x digital isolator in 16-pin wide body SOIC package. The values for the dimensions are shown in millimeters.

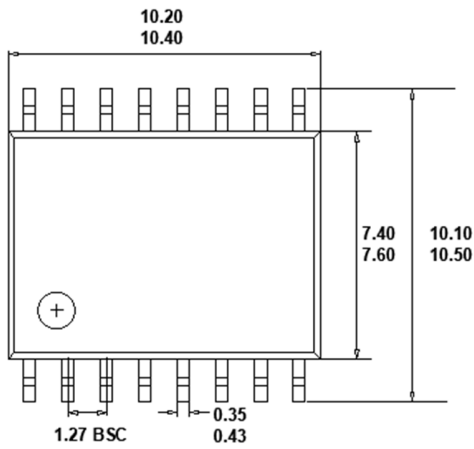

TOP VIEW

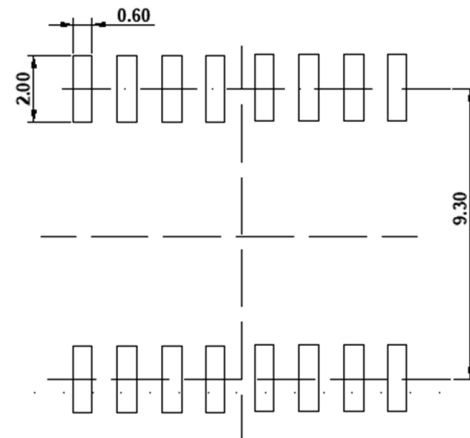

RECOMMENDED LAND PATTERN

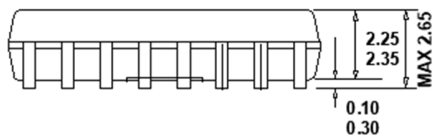

FRONT VIEW

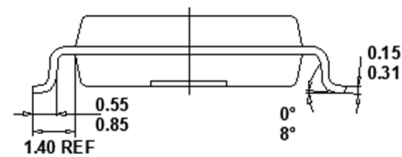

LEFT SIDE VIEW

12. Soldering Temperature (reflow) Profile

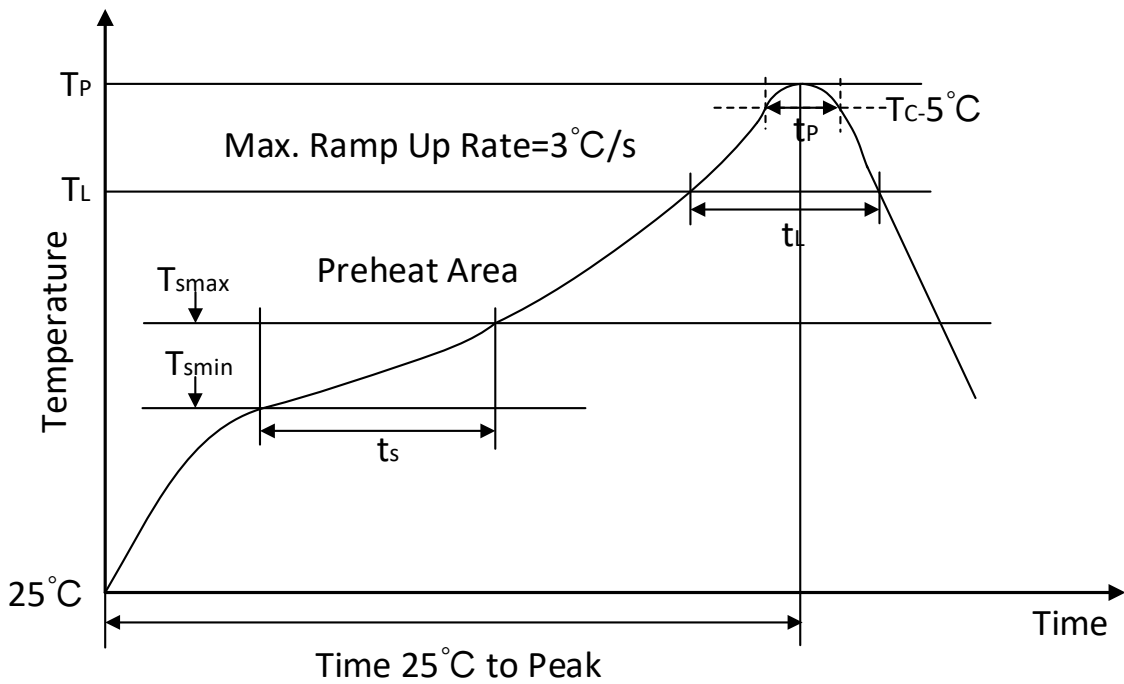
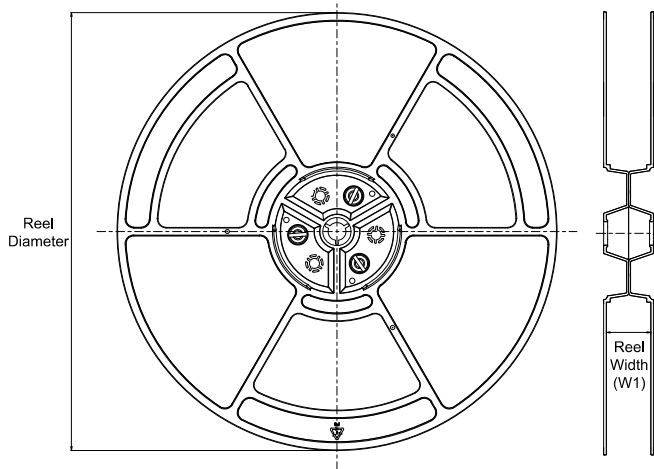
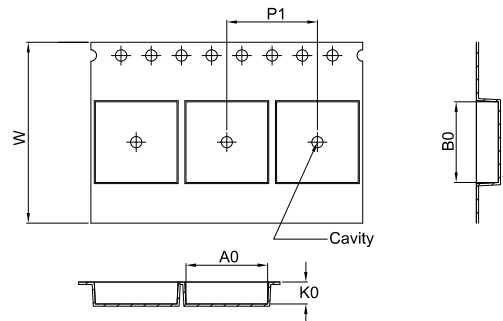

Figure. 13-1 Soldering Temperature (reflow) Profile

Tab. 13-1 Soldering Temperature Parameter

Profile Feature	Pb-Free Assembly
Average ramp rate (217 °C to Peak)	3°C/second max
Time of Preheat temp (from 150 °C to 200 °C)	60-120 second
Time to be maintained above 217 °C	60-150 second
Peak temperature	260 °C
Time within 5 °C of actual peak temp	30 second
Ramp down rate	6 °C /second max.
Time from 25°C to peak temp	8 minutes max

13. Tape and Reel Information
REEL DIMENSIONS

TAPE DIMENSIONS

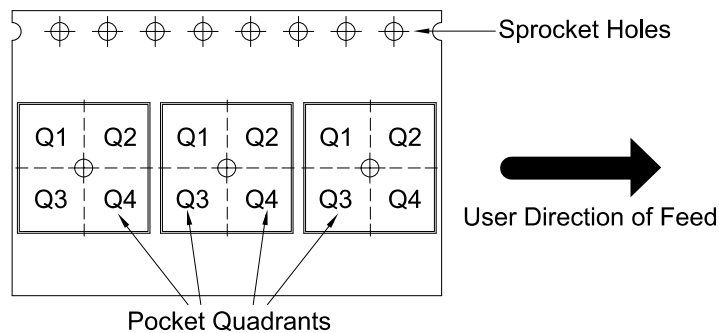
A0	Dimension designed to accommodate the component width
B0	Dimension designed to accommodate the component length
K0	Dimension designed to accommodate the component thickness
W	Overall width of the carrier tape
P1	Pitch between successive cavity centers

QUADRANT ASSIGNMENTS FOR PIN 1 ORIENTATION IN TAPE

*All dimensions are nominal

Device	Package Type	Package Drawing	Pins	SPQ	Reel Diameter (mm)	Reel Width W1 (mm)	A0 (mm)	B0 (mm)	K0 (mm)	P1 (mm)	W (mm)	Pin1 Quadrant
CA-IS3720LS	SOIC	S	8	2500	330	12.4	6.40	5.40	2.10	8.00	12.00	Q1
CA-IS3720LG	SOIC	G	8	1000	330	16.4	11.95	6.15	3.20	16.00	16.00	Q1
CA-IS3720LW	SOIC	W	16	1000	330	16.4	10.90	10.70	3.20	12.00	16.00	Q1
CA-IS3720HS	SOIC	S	8	2500	330	12.4	6.40	5.40	2.10	8.00	12.00	Q1
CA-IS3720HG	SOIC	G	8	1000	330	16.4	11.95	6.15	3.20	16.00	16.00	Q1
CA-IS3720HW	SOIC	W	16	1000	330	16.4	10.90	10.70	3.20	12.00	16.00	Q1
CA-IS3721LS	SOIC	S	8	2500	330	12.4	6.40	5.40	2.10	8.00	12.00	Q1
CA-IS3721LG	SOIC	G	8	1000	330	16.4	11.95	6.15	3.20	16.00	16.00	Q1
CA-IS3721LW	SOIC	W	16	1000	330	16.4	10.90	10.70	3.20	12.00	16.00	Q1
CA-IS3721HS	SOIC	S	8	2500	330	12.4	6.40	5.40	2.10	8.00	12.00	Q1
CA-IS3721HG	SOIC	G	8	1000	330	16.4	11.95	6.15	3.20	16.00	16.00	Q1
CA-IS3721HW	SOIC	W	16	1000	330	16.4	10.90	10.70	3.20	12.00	16.00	Q1
CA-IS3722LS	SOIC	S	8	2500	330	12.4	6.40	5.40	2.10	8.00	12.00	Q1
CA-IS3722LG	SOIC	G	8	1000	330	16.4	11.95	6.15	3.20	16.00	16.00	Q1
CA-IS3722LW	SOIC	W	16	1000	330	16.4	10.90	10.70	3.20	12.00	16.00	Q1
CA-IS3722HS	SOIC	S	8	2500	330	12.4	6.40	5.40	2.10	8.00	12.00	Q1
CA-IS3722HG	SOIC	G	8	1000	330	16.4	11.95	6.15	3.20	16.00	16.00	Q1
CA-IS3722HW	SOIC	W	16	1000	330	16.4	10.90	10.70	3.20	12.00	16.00	Q1

14. Important statement

The above information is for reference only and used for helping Chipanalog customers with design, research and development. Chipanalog reserves the rights to change the above information due to technological innovation without advance notice.

All Chipanalog products pass ex-factory test. As for specific practical applications, customers need to be responsible for evaluating and determining whether the products are applicable or not by themselves. Chipanalog's authorization for customers to use the resources are only limited to development of the related applications of the Chipanalog products. In addition to this, the resources cannot be copied or shown, and Chipanalog is not responsible for any claims, compensations, costs, losses, liabilities and the like arising from the use of the resources.

Trademark information

Chipanalog Inc.® and Chipanalog® are registered trademarks of Chipanalog.



<http://www.chipanalog.com>