

CA-IS374x High-Speed Four-Channel Digital Isolators

1. Features

- **Data Rate: DC to 150Mbps**
- **Robust Galvanic Isolation of Digital Signals**
 - High lifetime: >40 years
 - Up to 5000 V_{RMS} isolation rating(Wide-body Package)
 - ±150 kV/μs typical CMTI
- **Wide Supply Range:2.5V to 5.5V**
- **Wide Operating Temperature Range: -40°C to 125°C**
- **Enable Control Input With Tristate Output Function**
- **Default Output High (CA-IS374xH) and Low (CA-IS374xL) Options**
- **High Electromagnetic Immunity**
- **No Start-Up Initialization Required**
- **Low Power Consumption**
 - 1.5mA per channel at 1Mbps with V_{DD_} = 5.0V
 - 6.6mA per channel at 100Mbps with V_{DD_} = 5.0V
- **Best in Class Propagation Delay and Skew**
 - 12ns typical propagation delay
 - 2ns propagation delay
 - 1ns pulse width distortion
 - 5ns minimum pulse width
- **Package Options**
 - Narrow-body SOIC16-NB(N) package
 - Narrow-body SSOP16(B) package
 - Wide-body SOIC16-WB(W) package
- **Safety Regulatory Approvals**
 - VDE certification according to DIN EN IEC 60747-17(VDE 0884-17): 2021-10
 - UL certification according to UL 1577
 - CQC certification according to GB4943.1-2022
 - TUV certification

2. Applications

- Industrial Automation
- Motor Control
- Medical Systems
- Isolated Power Supplies
- Solar Inverter

- Isolated ADC,DAC

3. General Description

The CA-IS374x devices are high-performance four- channel, unidirectional digital isolators with up to 5kV_{RMS} wide-body package isolation rating and DC to 150Mbps ultra-fast data rate. The CA-IS374x devices offer high electromagnetic immunity and low emissions at low power consumption while isolating different ground domains and block high-voltage/high-current transients from sensitive or human interface circuitry. Each isolation channel has a logic input and output buffer separated by capacitive silicon dioxide (SiO₂) insulation barrier, the integrated Schmitt trigger on each input provide excellent noise immunity in automotive applications.

The CA-IS374x family offers all possible unidirectional channel configurations to accommodate any 4-channel design. The CA-IS3740 features 4 channels transferring digital signals in one direction and output enable for the B side is active-high. The CA-IS3741 device has three forward and one reverse-direction channels, making it ideal for applications such as isolated SPI, RS-485 communication. The CA-IS3742 provides further design flexibility with two channels in each direction. Both CA-IS3741 and CA-IS3742 come with individual enable control pins for each side of the isolator which can be used to put the outputs in high impedance for multi-master driving applications to reduce power consumption.

The CA-IS374x family features default outputs. When the input is either not powered or is open-circuit, the default output is low for devices with suffix L and high for devices with suffix H, see the *Ordering Information* for suffixes associated with each option.

The CA-IS374x family devices are specified over the -40°C to +125°C operating temperature range and are available in 16-pin SOIC wide body package, 16-pin SOIC narrow body package and 16-pin SSOP narrow body package .

Device information

Part number	Package	Package size (NOM)
CA-IS3740, CA-IS3741, CA-IS3742	SOIC16-NB (N)	9.90 mm × 3.90 mm
	SOIC16-WB(W)	10.30 mm × 7.50 mm
	SSOP16 (B)	4.90 mm × 3.90 mm

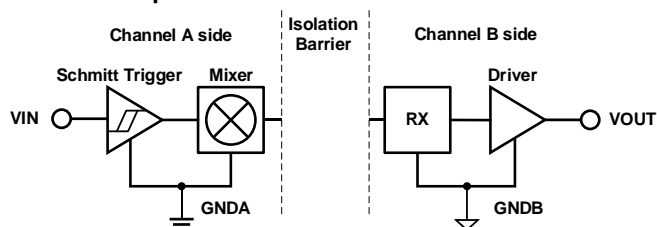
Simplified Channel Structure

GND A and GND B are the isolated grounds for A side and B side respectively.

4. Ordering Information
Table 4-1. Ordering Information

Part Number	Number of Inputs A Side	Number of Inputs B Side	Default Output	Isolation Rating (KV _{RMS})	Output Enable	Package
CA-IS3740LN	4	0	Low	3.75	Yes	SOIC16-NB
CA-IS3740LW	4	0	Low	5.0	Yes	SOIC16-WB
CA-IS3740HN	4	0	High	3.75	Yes	SOIC16-NB
CA-IS3740HW	4	0	High	5.0	Yes	SOIC16-WB
CA-IS3741LN	3	1	Low	3.75	Yes	SOIC16-NB
CA-IS3741LW	3	1	Low	5.0	Yes	SOIC16-WB
CA-IS3741HN	3	1	High	3.75	Yes	SOIC16-NB
CA-IS3741HW	3	1	High	5.0	Yes	SOIC16-WB
CA-IS3742LN	2	2	Low	3.75	Yes	SOIC16-NB
CA-IS3742LW	2	2	Low	5.0	Yes	SOIC16-WB
CA-IS3742HN	2	2	High	3.75	Yes	SOIC16-NB
CA-IS3742HW	2	2	High	5.0	Yes	SOIC16-WB
CA-IS3740HB	4	0	High	3.75	Yes	SSOP16
CA-IS3740LB	4	0	Low	3.75	Yes	SSOP16



CA-IS3740, CA-IS3741, CA-IS3742
Version 1.08

Shanghai Chipanalog Microelectronics Co., Ltd.

CA-IS3741HB	3	1	High	3.75	Yes	SSOP16
CA-IS3741LB	3	1	Low	3.75	Yes	SSOP16
CA-IS3742HB	2	2	High	3.75	Yes	SSOP16
CA-IS3742LB	2	2	Low	3.75	Yes	SSOP16

Contents

1.	Features	1			
2.	Applications.....	1			
3.	General Description	1			
4.	Ordering Information	2			
5.	Revision History	4			
6.	Pin Configuration and Functions	5			
7.	Specifications	6			
7.1.	Absolute Maximum Ratings ¹	6			
7.2.	ESD Ratings.....	6			
7.3.	Recommended Operating Conditions	6			
7.4.	Thermal Information	7			
7.5.	Power Rating	7			
7.6.	Insulation Specifications	8			
7.7.	Safety-Related Certifications	9			
7.8.	Electrical Characteristics	10			
7.9.	Supply Current Characteristics.....	11			
7.10.	Timing Characteristics.....	14			
8.	Parameter Measurement Information	16			
9.	Detailed Description	18			
9.1.	Overview	18			
9.2.	Functional Block Diagram	18			
9.3.	Device Operation Modes	19			
10.	Application and Implementation	20			
11.	Package Information	22			
11.1.	16-Pin Wide Body SOIC Package Outline	22			
11.2.	16-Pin Narrow Body SOIC Package Outline.....	23			
11.3.	16-Pin Narrow Body SSOP Package Outline	24			
12.	Soldering Temperature (reflow) Profile	25			
13.	Tape and Reel Information	26			
14.	Important Statement	27			

5. Revision History

Revision Number	Description	Revision Date	Page Changed
Version 1.00	N/A		N/A
Version 1.01	Changed V_{IORM} to 1414V, changed V_{IORM} to $1000V_{RMS}$, DC value to 1414V.		8 11, 12, 13
Version 1.02	Changed $V_{IT+(IN)}$ minimum value to 2.0V, changed $V_{IT-(IN)}$ maximum value to 0.8V; removed $V_{I(HYS)}$.		10
Version 1.03	Changed description of $V_{IT+(IN)}$ to Logic input High, $V_{IT-(IN)}$ to Logic input Low.		10
Version 1.04	Changed POD and Tape information	2022/12/19	22, 23, 24, 26
Version 1.05	Update VDE certification information	2023/09/13	7,8
Version 1.06	1. Updated VDE certification standard about V_{IMP} and V_{IOSM} 2. Updated TUV Certification number of IEC 62368-1 standard 3. Updated SSOP16 package certification of UL	2024/04/01	8
Version 1.07	Update the package of SSOP16 Change the TUV Certification number to the Client reference number	2024/09/26	24 9
Version 1.08	Update the CQC certification number for SSOP16 package Update the TUV certification number for SSOP16 package	2024/12/17	9

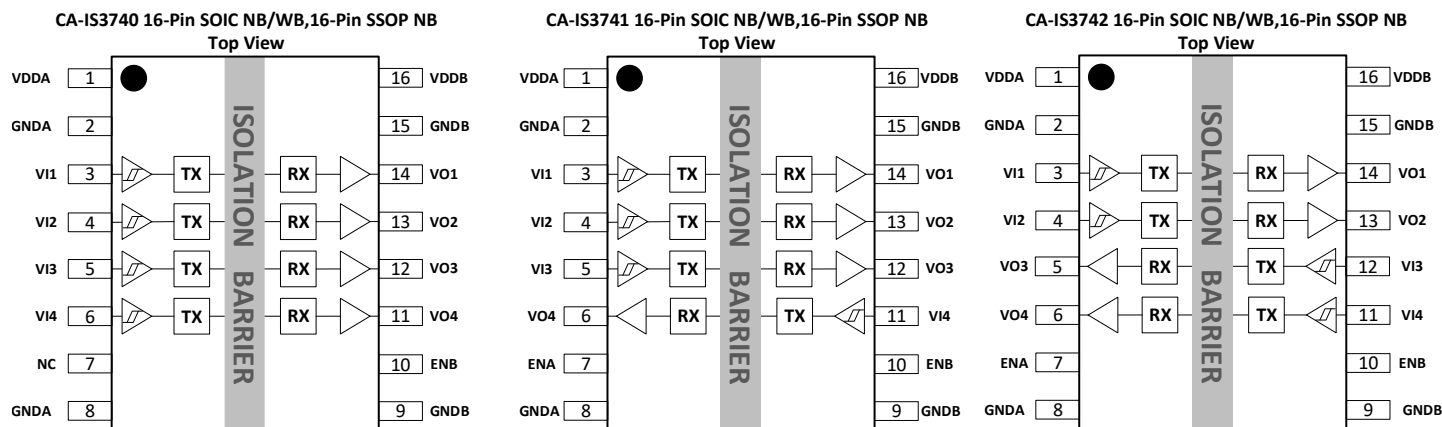
6. Pin Configuration and Functions

Figure 6-1. CA-IS374x pin configuration
Table 6-1. CA-IS374x pin description and function

16-SOIC Pin#			Name	Type	Description
CA-IS3740	CA-IS3741	CA-IS3742			
1	1	1	VDDA	Supply	Power supply for side A.
2, 8	2, 8	2, 8	GNDA	Ground	Ground reference for side A.
3	3	3	VI1	Digital I/O	Digital input 1 on side A, corresponds to logic output 1 on side B.
4	4	4	VI2	Digital I/O	Digital input 2 on side A, corresponds to logic output 2 on side B.
5	5	12	VI3	Digital I/O	Digital input 3 on side A/B, corresponds to logic output 3 on side B/A.
6	11	11	VI4	Digital I/O	Digital input 4 on side A/B, corresponds to logic output 4 on side B/A.
7	-	-	NC ¹	No Connect	Not internally connected. It can be left floating, tied to VDDA or tied to GNDA.
-	7	7	ENA ²	Digital I/O	Output enable A. Output pin on side A is enabled when ENA is high or floating; Output pin on side A is open and in high-impedance state when ENA is low.
9, 15	9, 15	9, 15	GNDB	Ground	Ground reference for side B.
10	10	10	ENB ²	Digital I/O	Output enable B. Output pin on side B is enabled when ENB is high or floating; Output pin on side B is open and in high-impedance state when ENB is low.
11	6	6	VO4	Digital I/O	Digital output 4 on side B/A, VO4 is the logic output for the VI4 input on side A/B.
12	12	5	VO3	Digital I/O	Digital output 3 on side B/A, VO3 is the logic output for the VI3 input on side A/B.
13	13	13	VO2	Digital I/O	Digital output 2 on side B, VO2 is the logic output for the VI2 input on side A.
14	14	14	VO1	Digital I/O	Digital output 1 on side B, VO1 is the logic output for the VI1 input on side A.
16	16	16	VDDB	Supply	Power supply for side B.

Notes:

1. No Connect. This pin is not internally connected. It can be left floating, tied to VDD_ or tied to GND.
2. Enable inputs ENA and ENB can be used to put the respective outputs in high impedance for multi master driving applications, external clock synchronization etc. With internal pull-up resistors, these pins can be connected to logic high or left floating to enable the outputs. If ENA, ENB are unused, it is recommended to connect these pins to a logic level, especially in the noisy environment.

7. Specifications

7.1. Absolute Maximum Ratings¹

Parameters		Minimum value	Maximum value	Unit
V_{DDA}, V_{DDB}	Power supply voltage ²	-0.5	7.0	V
V_{IN}	Voltage at VI_x, VO_x, EN_x	-0.5	$V_{DD_+} + 0.5^3$	V
I_O	Output current	-20	20	mA
T_J	Junction temperature		150	°C
T_{STG}	Storage temperature range	-65	150	°C

Notes:

- The stresses listed under “Absolute Maximum Ratings” are stress ratings only, not for functional operation condition. Exposure to absolute maximum rating conditions for extended periods may cause permanent damage to the device.
- All voltage values are with respect to the local ground terminal (GNDA or GNDB) and are peak voltage values.
- Maximum voltage must not be exceed 7 V.

7.2. ESD Ratings

Parameters		Value	Unit
V_{ESD} Electrostatic discharge	Human body model (HBM), per ANSI/ESDA/JEDEC JS-001, all pins ¹	±6000	V
	Charged device model (CDM), per JEDEC Specification JESD22-C101, all pins ²	±2000	

Notes:

- Per JEDEC document JEP155, 500V HBM allows safe manufacturing of standard ESD control process.
- Per JEDEC document JEP157, 250V HBM allows safe manufacturing of standard ESD control process.

7.3. Recommended Operating Conditions

PARAMETER		MIN	TYP	MAX	UNIT
V_{DDA}, V_{DDB}	Supply voltage on side A, B	2.375	3.3/5.0	5.5	V
$V_{DD} (UVLO+)$	V_{DD} Undervoltage-Lockout Threshold When Supply Voltage is Rising	1.95	2.24	2.375	V
$V_{DD} (UVLO-)$	V_{DD} Undervoltage-Lockout Threshold When Supply Voltage is Falling	1.88	2.10	2.325	V
$V_{HYS} (UVLO)$	V_{DD} Undervoltage-Lockout Threshold Hysteresis	70	140	250	mV
I_{OH}	High-level Output Current	$V_{DDO}^1 = 5V$	-4		mA
		$V_{DDO} = 3.3V$	-2		
		$V_{DDO} = 2.5V$	-1		
I_{OL}	Low-level Output Current	$V_{DDO} = 5V$		4	mA
		$V_{DDO} = 3.3V$		2	
		$V_{DDO} = 2.5V$		1	
V_{IH}	High-level Input Voltage	2.0			V
V_{IL}	Low-level Input Voltage			0.8	V
DR	Data Rate	0		150	Mbps
T_A	Ambient Temperature	-40	27	125	°C

Note:

- V_{DDO} = Output-side supply V_{DD} .

7.4. Thermal Information

Thermal Metric	CA-IS374x			Unit
	SOIC16-NB(N)	SOIC16-WB(W)	SSOP16(B)	
$R_{\theta JA}$ Junction-to-ambient thermal resistance	96.2	83.4	110	°C/W

7.5. Power Rating

Parameters	Test conditions	MIN	TYP	MAX	Unit
CA-IS3740					
P_D Maximum Power Dissipation	$V_{DDA} = V_{DDB} = 5.5\text{ V}$, $C_L = 15\text{ pF}$, $T_J = 150^\circ\text{C}$, Input a 75-MHz 50% duty cycle square wave.			334	mW
P_{DA} Maximum Power Dissipation on Side-A				36	mW
P_{DB} Maximum Power Dissipation on Side-B				298	mW
CA-IS3741					
P_D Maximum Power Dissipation	$V_{DDA} = V_{DDB} = 5.5\text{ V}$, $C_L = 15\text{ pF}$, $T_J = 150^\circ\text{C}$, Input a 75-MHz 50% duty cycle square wave.			334	mW
P_{DA} Maximum Power Dissipation on Side-A				100	mW
P_{DB} Maximum Power Dissipation on Side-B				234	mW
CA-IS3742					
P_D Maximum Power Dissipation	$V_{DDA} = V_{DDB} = 5.5\text{ V}$, $C_L = 15\text{ pF}$, $T_J = 150^\circ\text{C}$, Input a 75-MHz 50% duty cycle square wave.			334	mW
P_{DA} Maximum Power Dissipation on Side-A				167	mW
P_{DB} Maximum Power Dissipation on Side-B				167	mW

7.6. Insulation Specifications

Parameters		Test conditions	Value			Unit
			W	N	B	
CLR	External clearance	Shortest terminal-to-terminal distance through air	8	4	4	mm
CPG	External creepage	Shortest terminal-to-terminal distance across the package surface	8	4	4	mm
DTI	Distance through the insulation	Minimum internal gap (internal clearance)	28	28	28	μm
CTI	Comparative tracking index	DIN EN 60112 (VDE 0303-11); IEC 60112	>600	>600	>600	V
	Material group	Per IEC 60664-1	I	I	I	
	Overvoltage category per IEC 60664-1	Rated mains voltage ≤ 150 V _{RMS}	I-IV	I-IV	I-IV	
		Rated mains voltage ≤ 300 V _{RMS}	I-IV	I-III	I-III	
		Rated mains voltage ≤ 600 V _{RMS}	I-IV	n/a	n/a	
		Rated mains voltage ≤ 1000 V _{RMS}	I-III	n/a	n/a	
DIN V VDE V 0884-17:2021-10¹						
V _{IORM}	Maximum repetitive peak isolation voltage	AC voltage (bipolar)	1414	566	566	V _{PK}
V _{IOWM}	Maximum operating isolation voltage	AC voltage; time-dependent dielectric breakdown (TDDb) test	1000	400	400	V _{RMS}
		DC voltage	1414	566	566	V _{DC}
V _{IOTM}	Maximum transient isolation voltage	V _{TEST} = V _{IOTM} , t = 60 s (qualification); V _{TEST} = 1.2 × V _{IOTM} , t = 1 s (100% product test)	7070	5300	5300	V _{PK}
V _{IMP}	Maximum impulse voltage	1.2/50 μs waveform per IEC 62368-1	8701	5000	4076	V _{PK}
V _{IOSM}	Maximum surge isolation voltage ²	V _{IOSM} ≥ 1.3 × V _{IMP} ; Tested in oil (qualification test), 1.2/50 μs waveform per IEC 62368-1	11312	6500	5300	V _{PK}
Q _{pd}	Apparent charge ³	Method a, after input/output safety test of the subgroup 2/3, V _{ini} = V _{IOTM} , t _{ini} = 60 s; V _{pd(m)} = 1.2 × V _{IORM} , t _m = 10 s	≤5			pC
		Method a, after environmental test of the subgroup 1, V _{ini} = V _{IOTM} , t _{ini} = 60 s; V _{pd(m)} = 1.6 × V _{IORM} , t _m = 10 s	≤5			
		Method b, at routine test (100% production test) and preconditioning (type test) V _{ini} = 1.2 × V _{IOTM} , t _{ini} = 1 s; V _{pd(m)} = 1.875 × V _{IORM} , t _m = 1 s (W) V _{pd(m)} = 1.5 × V _{IORM} , t _m = 1 s (N/B)	≤5			
C _{IO}	Barrier capacitance, input to output ⁴	V _{IO} = 0.4 × sin(2πft), f = 1 MHz	~0.5			pF
R _{IO}	Isolation resistance ⁴	V _{IO} = 500 V, T _A = 25°C	>10 ¹²			Ω
		V _{IO} = 500 V, 100°C ≤ T _A ≤ 125°C	>10 ¹¹			
		V _{IO} = 500 V at T _S = 150°C	>10 ⁹			
	Pollution degree		2			
UL 1577						
V _{ISO}	Maximum withstanding isolation voltage	V _{TEST} = V _{ISO} , t = 60 s (qualification) V _{TEST} = 1.2 × V _{ISO} , t = 1 s (100% production test)	5000	3750	3750	V _{RMS}

Notes:

- This coupler is suitable for “safe electrical insulation” only within the safety ratings. Compliance with the safety ratings shall be ensured by means of suitable protective circuits.
- Devices are immersed in oil during surge characterization test.
- The characterization charge is discharging charge (pd) caused by partial discharge.
- Capacitance and resistance are measured with all pins on field-side and logic-side tied together.

7.7. Safety-Related Certifications

VDE	UL	CQC	TUV
Certified according to DIN EN IEC 60747-17 (VDE 0884-17):2021-10; EN IEC 60747-17:2020+AC:2021	Certified according to UL 1577 Component Recognition Program	Certified according to GB4943.1-2022	Certified according to EN 61010-1 and EN 62368-1
Basic Isolation (SOIC16-NB / SSOP16): V_{IORM} : 566V _{pk} V_{IOTM} : 5300V _{pk} V_{IOSM} : 6500V _{pk} (SOIC16-NB) V_{IOSM} : 5300V _{pk} (SSOP16) Reinforced Isolation (SOIC16-WB): V_{IORM} : 1414V _{pk} V_{IOTM} : 7070V _{pk} V_{IOSM} : 11312V _{pk}	Single protection: SOIC16-NB: 3750V _{RMS} SSOP16: 3750V _{RMS} SOIC16-WB: 5000V _{RMS}	SOIC16-NB: Basic insulation SSOP16: Basic insulation SOIC16-WB: Reinforced insulation (Altitude ≤ 5000m)	EN 61010-1 SOIC16-WB: 5000V _{RMS} SOIC16-NB: 3750V _{RMS} SSOP16: 3750V _{RMS} EN 62368-1 SOIC16-WB: 5000V _{RMS} SOIC16-NB: 3750V _{RMS} SSOP16: 3750V _{RMS}
Certification number: 40057278 (Reinforced) 40052786 (Basic)	Certificate number: E511334	Certificate number: SOIC16-WB: CQC23001406424 SOIC16-NB: CQC23001406179 SSOP16: CQC24001453031	Client reference number: 2253313

7.8. Electrical Characteristics
 $V_{DDA} = V_{DDB} = 5\text{ V} \pm 10\%$, $T_A = -40\text{ to }125^\circ\text{C}$ (over recommended operating conditions, unless otherwise specified)

Parameters		Test conditions	MIN	TYP	MAX	UNIT
V_{OH}	High-level Output Voltage	$I_{OH} = -4\text{mA}$; See Figure 8-2	$V_{DDO}^{1-0.4}$	4.8		V
V_{OL}	Low-level Output Voltage	$I_{OL} = 4\text{mA}$; See Figure 8-2		0.2	0.4	V
$V_{IT+(IN)}$	Logic input High		2.0			V
$V_{IT-(IN)}$	Logic input Low				0.8	V
I_{IH}	High-Level Input Leakage Current	$V_{IH} = V_{DDA}$ at INx or ENx			20	μA
I_{IL}	Low-Level Input Leakage Current	$V_{IL} = 0\text{ V}$ at INx	-20			μA
Z_O	Output Impedance ²			50		Ω
CMTI Immunity	Common-mode Transient Immunity	$V_I = V_{DDI}^1$ or 0 V, $V_{CM} = 1200\text{ V}$; See Figure 8-4	100	150		kV/ μs
C_i	Input Capacitance ³	$V_I = V_{DD}/2 + 0.4 \times \sin(2\pi ft)$, $f = 1\text{ MHz}$, $V_{DD} = 5\text{ V}$		2		pF

Notes:

- V_{DDI} = Input-side supply V_{DD} , V_{DDO} = Output-side supply V_{DD} .
- The nominal output impedance of each isolator driver is $50\ \Omega \pm 40\%$.
- Measured from pin to Ground.

 $V_{DDA} = V_{DDB} = 3.3\text{ V} \pm 10\%$, $T_A = -40\text{ to }125^\circ\text{C}$ (over recommended operating conditions, unless otherwise specified)

Parameters		Test conditions	MIN	TYP	MAX	UNIT
V_{OH}	High-level Output Voltage	$I_{OH} = -2\text{mA}$; See Figure 8-2	$V_{DDO}^{1-0.4}$	3.1		V
V_{OL}	Low-level Output Voltage	$I_{OL} = 2\text{mA}$; See Figure 8-2		0.2	0.4	V
$V_{IT+(IN)}$	Logic input High		2.0			V
$V_{IT-(IN)}$	Logic input Low				0.8	V
I_{IH}	High-Level Input Leakage Current	$V_{IH} = V_{DDA}$ at INx or ENx			20	μA
I_{IL}	Low-Level Input Leakage Current	$V_{IL} = 0\text{ V}$ at INx	-20			μA
Z_O	Output Impedance ²			50		Ω
CMTI Immunity	Common-mode Transient Immunity	$V_I = V_{DDI}^1$ or 0 V, $V_{CM} = 1200\text{ V}$; See Figure 8-4	100	150		kV/ μs
C_i	Input Capacitance ³	$V_I = V_{DD}/2 + 0.4 \times \sin(2\pi ft)$, $f = 1\text{ MHz}$, $V_{DD} = 3.3\text{ V}$		2		pF

Notes:

- V_{DDI} = Input-side supply V_{DD} , V_{DDO} = Output-side supply V_{DD} .
- The nominal output impedance of each isolator driver is $50\ \Omega \pm 40\%$.
- Measured from pin to Ground.

 $V_{DDA} = V_{DDB} = 2.5\text{ V} \pm 10\%$, $T_A = -40\text{ to }125^\circ\text{C}$ (over recommended operating conditions, unless otherwise specified)

Parameters		Test conditions	MIN	TYP	MAX	UNIT
V_{OH}	High-level Output Voltage	$I_{OH} = -1\text{mA}$; See Figure 8-2	$V_{DDO}^{1-0.4}$	2.3		V
V_{OL}	Low-level Output Voltage	$I_{OL} = 1\text{mA}$; See Figure 8-2		0.2	0.4	V
$V_{IT+(IN)}$	Logic input High		2.0			V
$V_{IT-(IN)}$	Logic input Low				0.8	V
I_{IH}	High-Level Input Leakage Current	$V_{IH} = V_{DDA}$ at INx or ENx			20	μA
I_{IL}	Low-Level Input Leakage Current	$V_{IL} = 0\text{ V}$ at INx	-20			μA
Z_O	Output Impedance ²			50		Ω
CMTI Immunity	Common-mode Transient Immunity	$V_I = V_{DDI}^1$ or 0 V, $V_{CM} = 1200\text{ V}$; See Figure 8-4	100	150		kV/ μs
C_i	Input Capacitance ³	$V_I = V_{DD}/2 + 0.4 \times \sin(2\pi ft)$, $f = 1\text{ MHz}$, $V_{DD} = 2.5\text{ V}$		2		pF

Notes:

- V_{DDI} = Input-side supply V_{DD} , V_{DDO} = Output-side supply V_{DD} .
- The nominal output impedance of each isolator driver is $50\ \Omega \pm 40\%$.
- Measured from pin to Ground.

7.9. Supply Current Characteristics
 $V_{DDA} = V_{DDB} = 5\text{ V} \pm 10\%$, $T_A = -40$ to 125°C (over recommended operating conditions, unless otherwise specified)

Parameters	Test conditions	SUPPLY CURRENT	MIN	TYP	MAX	UNIT
CA-IS3740						
Supply Current – Outputs disabled	ENB = 0 V; $V_{IN} = 0\text{V}$ (CA-IS3740L); $V_{IN} = V_{DDA}$ (CA-IS3740H)	I_{DDA}		1.3	2.1	mA
		I_{DDB}		2.5	3.5	
	ENB = 0 V; $V_{IN} = V_{DDA}$ (CA-IS3740L); $V_{IN} = 0\text{V}$ (CA-IS3740H)	I_{DDA}		6.4	9.5	
		I_{DDB}		2.7	3.6	
Supply Current – DC Signal	ENB = V_{DDB} ; $V_{IN} = 0\text{V}$ (CA-IS3740L); $V_{IN} = V_{DDA}$ (CA-IS3740H)	I_{DDA}		1.3	2.1	
		I_{DDB}		2.7	3.9	
	ENB = V_{DDB} ; $V_{IN} = V_{DDA}$ (CA-IS3740L); $V_{IN} = 0\text{V}$ (CA-IS3740H)	I_{DDA}		6.4	9.5	
		I_{DDB}		2.7	4.0	
Supply Current – AC Signal	ENB = V_{DDB} ; All Channels Switching with 50% Duty Cycle Square Wave Clock Input with 5V Amplitude; $C_L = 15\text{ pF}$ for Each Channel.	1Mbps (500kHz)	I_{DDA}		3.9	5.8
			I_{DDB}		4.4	6.1
		10Mbps (5MHz)	I_{DDA}		3.9	5.8
			I_{DDB}		18.7	24.8
		100Mbps (50MHz)	I_{DDA}		4.7	6.8
			I_{DDB}		41.0	54.7
CA-IS3741						
Supply Current – Outputs disabled	ENA = ENB = 0 V; $V_{IN} = 0\text{V}$ (CA-IS3741L); $V_{IN} = V_{DDI}^1$ (CA-IS3741H)	I_{DDA}		1.5	2.4	mA
		I_{DDB}		2.3	3.6	
	ENA = ENB = 0 V; $V_{IN} = V_{DDI}$ (CA-IS3741L); $V_{IN} = 0\text{V}$ (CA-IS3741H)	I_{DDA}		4.1	6.8	
		I_{DDB}		3.2	5.1	
Supply Current – DC Signal	ENA = ENB = V_{DDI} ; $V_{IN} = 0\text{V}$ (CA-IS3741L); $V_{IN} = V_{DDI}$ (CA-IS3741H)	I_{DDA}		1.6	2.5	
		I_{DDB}		2.5	3.9	
	ENA = ENB = V_{DDI} ; $V_{IN} = V_{DDI}$ (CA-IS3741L); $V_{IN} = 0\text{V}$ (CA-IS3741H)	I_{DDA}		4.2	6.9	
		I_{DDB}		3.5	5.4	
Supply Current – AC Signal	ENA = ENB = V_{DDI} ; All Channels Switching with 50% Duty Cycle Square Wave Clock Input with 5V Amplitude; $C_L = 15\text{ pF}$ for Each Channel.	1Mbps (500kHz)	I_{DDA}		3.3	5.2
			I_{DDB}		4.1	6.2
		10Mbps (5MHz)	I_{DDA}		6.9	9.9
			I_{DDB}		14.0	19.5
		100Mbps (50MHz)	I_{DDA}		14.3	19.8
			I_{DDB}		32.5	44.0
CA-IS3742						
Supply Current – Outputs disabled	ENA = ENB = 0 V; $V_{IN} = 0\text{V}$ (CA-IS3742L); $V_{IN} = V_{DDI}^1$ (CA-IS3742H)	I_{DDA}		2.2	3.3	mA
		I_{DDB}		2.2	3.3	
	ENA = ENB = 0 V; $V_{IN} = V_{DDI}$ (CA-IS3742L); $V_{IN} = 0\text{V}$ (CA-IS3742H)	I_{DDA}		4.8	7.0	
		I_{DDB}		4.8	7.0	
Supply Current – DC Signal	ENA = ENB = V_{DDI} ; $V_{IN} = 0\text{V}$ (CA-IS3742L); $V_{IN} = V_{DDI}$ (CA-IS3742H)	I_{DDA}		2.4	3.5	
		I_{DDB}		2.4	3.5	
	ENA = ENB = V_{DDI} ; $V_{IN} = V_{DDI}$ (CA-IS3742L); $V_{IN} = 0\text{V}$ (CA-IS3742H)	I_{DDA}		4.9	7.1	
		I_{DDB}		4.9	7.1	
Supply Current – AC Signal	ENA = ENB = V_{DDI} ; All Channels Switching with 50% Duty Cycle Square Wave Clock Input with 5V Amplitude; $C_L = 15\text{ pF}$ for Each Channel.	1Mbps (500kHz)	I_{DDA}		4.4	6.3
			I_{DDB}		4.4	6.3
		10Mbps (5MHz)	I_{DDA}		11.8	16.0
			I_{DDB}		11.8	16.0
		100Mbps (50MHz)	I_{DDA}		24.0	33.0
			I_{DDB}		24.0	33.0
Note:						
1. V_{DDI} = Input-side supply V_{DD} .						

CA-IS3740, CA-IS3741, CA-IS3742
Version 1.08

Shanghai Chipanalog Microelectronics Co., Ltd.

 $V_{DDA} = V_{DDB} = 3.3\text{ V} \pm 10\%$, $T_A = -40\text{ to }125^\circ\text{C}$ (over recommended operating conditions, unless otherwise specified)

Parameters	Test conditions	SUPPLY CURRENT	MIN	TYP	MAX	UNIT
CA-IS3740						
Supply Current – Outputs disabled	ENB = 0 V; $V_{IN} = 0\text{V}$ (CA-IS3740L); $V_{IN} = V_{DDA}$ (CA-IS3740H)	I_{DDA}		1.4	2.0	mA
		I_{DDB}		2.4	3.5	
	ENB = 0 V; $V_{IN} = V_{DDA}$ (CA-IS3740L); $V_{IN} = 0\text{V}$ (CA-IS3740H)	I_{DDA}		6.3	9.5	
		I_{DDB}		2.4	3.6	
Supply Current – DC Signal	ENB = V_{DDB} ; $V_{IN} = 0\text{V}$ (CA-IS3740L); $V_{IN} = V_{DDA}$ (CA-IS3740H)	I_{DDA}		1.4	2.0	
		I_{DDB}		2.6	3.7	
	ENB = V_{DDB} ; $V_{IN} = V_{DDA}$ (CA-IS3740L); $V_{IN} = 0\text{V}$ (CA-IS3740H)	I_{DDA}		6.2	9.3	
		I_{DDB}		2.6	3.8	
Supply Current – AC Signal	ENB = V_{DDB} ; All Channels Switching with 50% Duty Cycle Square Wave Clock Input with 3.3V Amplitude; $C_L = 15\text{ pF}$ for Each Channel.	1Mbps (500kHz)	I_{DDA}		3.8	5.7
			I_{DDB}		3.7	5.1
		10Mbps (5MHz)	I_{DDA}		3.8	5.7
			I_{DDB}		13.2	17.5
		100Mbps (50MHz)	I_{DDA}		4.6	6.8
			I_{DDB}		28.7	38.3
CA-IS3741						
Supply Current – Outputs disabled	ENA = ENB = 0 V; $V_{IN} = 0\text{V}$ (CA-IS3741L); $V_{IN} = V_{DDI}^1$ (CA-IS3741H)	I_{DDA}		1.5	2.4	mA
		I_{DDB}		2.3	3.5	
	ENA = ENB = 0 V; $V_{IN} = V_{DDI}$ (CA-IS3741L); $V_{IN} = 0\text{V}$ (CA-IS3741H)	I_{DDA}		4.0	6.7	
		I_{DDB}		3.2	5.1	
Supply Current – DC Signal	ENA = ENB = V_{DDI} ; $V_{IN} = 0\text{V}$ (CA-IS3741L); $V_{IN} = V_{DDI}^1$ (CA-IS3741H)	I_{DDA}		1.5	2.4	
		I_{DDB}		2.4	3.7	
	ENA = ENB = V_{DDI} ; $V_{IN} = V_{DDI}$ (CA-IS3741L); $V_{IN} = 0\text{V}$ (CA-IS3741H)	I_{DDA}		4.1	6.8	
		I_{DDB}		3.3	5.2	
Supply Current – AC Signal	ENA = ENB = V_{DDI} ; All Channels Switching with 50% Duty Cycle Square Wave Clock Input with 3.3V Amplitude; $C_L = 15\text{ pF}$ for Each Channel.	1Mbps (500kHz)	I_{DDA}		3.0	4.9
			I_{DDB}		3.6	5.4
		10Mbps (5MHz)	I_{DDA}		5.5	8.0
			I_{DDB}		10.0	13.9
		100Mbps (50MHz)	I_{DDA}		10.3	14.5
			I_{DDB}		21.9	29.7
CA-IS3742						
Supply Current – Outputs disabled	ENA = ENB = 0 V; $V_{IN} = 0\text{V}$ (CA-IS3742L); $V_{IN} = V_{DDI}^1$ (CA-IS3742H)	I_{DDA}		2.3	3.2	mA
		I_{DDB}		2.3	3.2	
	ENA = ENB = 0 V; $V_{IN} = V_{DDI}$ (CA-IS3742L); $V_{IN} = 0\text{V}$ (CA-IS3742H)	I_{DDA}		4.9	6.9	
		I_{DDB}		4.9	6.9	
Supply Current – DC Signal	ENA = ENB = V_{DDI} ; $V_{IN} = 0\text{V}$ (CA-IS3742L); $V_{IN} = V_{DDI}^1$ (CA-IS3742H)	I_{DDA}		2.4	3.3	
		I_{DDB}		2.4	3.3	
	ENA = ENB = V_{DDI} ; $V_{IN} = V_{DDI}$ (CA-IS3742L); $V_{IN} = 0\text{V}$ (CA-IS3742H)	I_{DDA}		5.0	7.0	
		I_{DDB}		5.0	7.0	
Supply Current – AC Signal	ENA = ENB = V_{DDI} ; All Channels Switching with 50% Duty Cycle Square Wave Clock Input with 3.3V Amplitude; $C_L = 15\text{ pF}$ for Each Channel.	1Mbps (500kHz)	I_{DDA}		4.0	5.9
			I_{DDB}		4.0	5.9
		10Mbps (5MHz)	I_{DDA}		8.9	12.0
			I_{DDB}		8.9	12.0
		100Mbps (50MHz)	I_{DDA}		17.4	24.0
			I_{DDB}		17.4	24.0
Note:						
1. V_{DDI} = Input-side supply V_{DD} .						

$V_{DDA} = V_{DDB} = 2.5\text{ V} \pm 10\%$, $T_A = -40$ to 125°C (over recommended operating conditions, unless otherwise specified)

Parameters	Test conditions	SUPPLY CURRENT	MIN	TYP	MAX	UNIT
CA-IS3740						
Supply Current – Outputs disabled	ENB = 0 V; $V_{IN} = 0\text{V}$ (CA-IS3740L); $V_{IN} = V_{DDA}$ (CA-IS3740H)	I_{DDA}		1.4	2.0	mA
		I_{DDB}		2.4	3.4	
	ENB = 0 V; $V_{IN} = V_{DDA}$ (CA-IS3740L); $V_{IN} = 0\text{V}$ (CA-IS3740H)	I_{DDA}		6.3	9.3	
		I_{DDB}		2.4	3.5	
Supply Current – DC Signal	ENB = V_{DDB} ; $V_{IN} = 0\text{V}$ (CA-IS3740L); $V_{IN} = V_{DDA}$ (CA-IS3740H)	I_{DDA}		1.4	2.0	
		I_{DDB}		2.5	3.6	
	ENB = V_{DDB} ; $V_{IN} = V_{DDA}$ (CA-IS3740L); $V_{IN} = 0\text{V}$ (CA-IS3740H)	I_{DDA}		6.3	9.3	
		I_{DDB}		2.5	3.7	
Supply Current – AC Signal	ENB = V_{DDB} ; All Channels Switching with 50% Duty Cycle Square Wave Clock Input with 2.5V Amplitude; $C_L = 15\text{ pF}$ for Each Channel.	1Mbps (500kHz)	I_{DDA}		3.8	5.6
			I_{DDB}		3.4	4.7
		10Mbps (5MHz)	I_{DDA}		3.8	5.6
			I_{DDB}		10.6	14.1
		100Mbps (50MHz)	I_{DDA}		4.7	7.0
			I_{DDB}		22.4	30.0
CA-IS3741						
Supply Current – Outputs disabled	ENA = ENB = 0 V; $V_{IN} = 0\text{V}$ (CA-IS3741L); $V_{IN} = V_{DDI}^1$ (CA-IS3741H)	I_{DDA}		1.5	2.3	mA
		I_{DDB}		2.3	3.5	
	ENA = ENB = 0 V; $V_{IN} = V_{DDI}$ (CA-IS3741L); $V_{IN} = 0\text{V}$ (CA-IS3741H)	I_{DDA}		4.0	6.7	
		I_{DDB}		3.2	5.0	
Supply Current – DC Signal	ENA = ENB = V_{DDI} ; $V_{IN} = 0\text{V}$ (CA-IS3741L); $V_{IN} = V_{DDI}^1$ (CA-IS3741H)	I_{DDA}		1.5	2.4	
		I_{DDB}		2.4	3.7	
	ENA = ENB = V_{DDI} ; $V_{IN} = V_{DDI}$ (CA-IS3741L); $V_{IN} = 0\text{V}$ (CA-IS3741H)	I_{DDA}		4.0	6.7	
		I_{DDB}		3.3	5.1	
Supply Current – AC Signal	ENA = ENB = V_{DDI} ; All Channels Switching with 50% Duty Cycle Square Wave Clock Input with 2.5V Amplitude; $C_L = 15\text{ pF}$ for Each Channel.	1Mbps (500kHz)	I_{DDA}		3.0	4.8
			I_{DDB}		3.4	5.1
		10Mbps (5MHz)	I_{DDA}		4.8	7.2
			I_{DDB}		8.3	11.5
		100Mbps (50MHz)	I_{DDA}		8.4	11.9
			I_{DDB}		16.7	22.9
CA-IS3742						
Supply Current – Outputs disabled	ENA = ENB = 0 V; $V_{IN} = 0\text{V}$ (CA-IS3742L); $V_{IN} = V_{DDI}^1$ (CA-IS3742H)	I_{DDA}		2.2	3.2	mA
		I_{DDB}		2.2	3.2	
	ENA = ENB = 0 V; $V_{IN} = V_{DDI}$ (CA-IS3742L); $V_{IN} = 0\text{V}$ (CA-IS3742H)	I_{DDA}		4.6	6.8	
		I_{DDB}		4.6	6.8	
Supply Current – DC Signal	ENA = ENB = V_{DDI} ; $V_{IN} = 0\text{V}$ (CA-IS3742L); $V_{IN} = V_{DDI}^1$ (CA-IS3742H)	I_{DDA}		2.2	3.2	
		I_{DDB}		2.2	3.2	
	ENA = ENB = V_{DDI} ; $V_{IN} = V_{DDI}$ (CA-IS3742L); $V_{IN} = 0\text{V}$ (CA-IS3742H)	I_{DDA}		4.7	6.9	
		I_{DDB}		4.7	6.9	
Supply Current – AC Signal	ENA = ENB = V_{DDI} ; All Channels Switching with 50% Duty Cycle Square Wave Clock Input with 2.5V Amplitude; $C_L = 15\text{ pF}$ for Each Channel.	1Mbps (500kHz)	I_{DDA}		3.9	5.6
			I_{DDB}		3.9	5.6
		10Mbps (5MHz)	I_{DDA}		7.5	10.3
			I_{DDB}		7.5	10.3
		100Mbps (50MHz)	I_{DDA}		14.4	19.7
			I_{DDB}		14.4	19.7
Note:						
1. V_{DDI} = Input-side supply V_{DD} .						

7.10. Timing Characteristics
 $V_{DDA} = V_{ddb} = 5\text{ V} \pm 10\%$, $T_A = -40$ to 125°C (over recommended operating conditions, unless otherwise specified)

Parameters		Test conditions	MIN	TYP	MAX	UNIT				
DR	Data Rate				150	Mbps				
PW_{min}	Minimum Pulse Width				5	ns				
t_{PLH} , t_{PHL}	Propagation Delay Time	See Figure 8-1	5	12	16	ns				
PWD	Pulse Width Distortion $ t_{PLH} - t_{PHL} $						0.2	4.5	ns	
$t_{sk(o)}$	Channel-to-Channel Output Skew Time ¹	Same-direction channels		0.4	2.5	ns				
$t_{sk(pp)}$	Part-to-Part Output Skew Time ²			2.0	4.5	ns				
t_r	Output Signal Rise Time	See Figure 8-1		2.5	4	ns				
t_f	Output Signal Fall Time	See Figure 8-1		2.5	4	ns				
t_{PHZ}	Disable Propagation Delay, High to High Impedance Output	See Figure 8-2		8	13	ns				
t_{PLZ}	Disable Propagation Delay, Low to High Impedance Output						8	17	ns	
t_{PZH}	Enable Propagation Delay, High Impedance to High Output						CA-IS374x L	10	20	ns
							CA-IS374x H	15	30	ns
t_{PZL}	Enable Propagation Delay, High Impedance to Low Output						CA-IS374x L	10	25	ns
							CA-IS374x H	15	30	ns
t_{DO}	Default Output Delay Time from Input Power Loss	See Figure 8-3		8	12	μs				
t_{SU}	Start-up Time			15	40	μs				

Notes:

- $t_{sk(o)}$ is the skew between outputs of a single device with all driving inputs connected together and the outputs switching in the same direction while driving identical loads.
- $t_{sk(pp)}$ is the magnitude of the difference in propagation delay times between any terminals of different devices switching in the same direction while operating at identical supply voltages, temperature, input signals and loads.

 $V_{DDA} = V_{ddb} = 3.3\text{ V} \pm 10\%$, $T_A = -40$ to 125°C (over recommended operating conditions, unless otherwise specified)

PARAMETER		TEST CONDITIONS	MIN	TYP	MAX	UNIT				
DR	Data Rate				150	Mbps				
PW_{min}	Minimum Pulse Width				5	ns				
t_{PLH} , t_{PHL}	Propagation Delay Time	See Figure 8-1	5	12	16	ns				
PWD	Pulse Width Distortion $ t_{PLH} - t_{PHL} $						0.2	4.5	ns	
$t_{sk(o)}$	Channel-to-Channel Output Skew Time ¹	Same-direction channels		0.4	2.5	ns				
$t_{sk(pp)}$	Part-to-Part Output Skew Time ²			2.0	4.5	ns				
t_r	Output Signal Rise Time	See Figure 8-1		2.5	4	ns				
t_f	Output Signal Fall Time	See Figure 8-1		2.5	4	ns				
t_{PHZ}	Disable Propagation Delay, High to High Impedance Output	See Figure 8-2		8	13	ns				
t_{PLZ}	Disable Propagation Delay, Low to High Impedance Output						8	17	ns	
t_{PZH}	Enable Propagation Delay, High Impedance to High Output						CA-IS374x L	10	20	ns
							CA-IS374x H	15	30	ns
t_{PZL}	Enable Propagation Delay, High Impedance to Low Output						CA-IS374x L	10	25	ns
							CA-IS374x H	15	30	ns
t_{DO}	Default Output Delay Time from Input Power Loss	See Figure 8-3		8	12	μs				
t_{SU}	Start-up Time			15	40	μs				

Notes:

- $t_{sk(o)}$ is the skew between outputs of a single device with all driving inputs connected together and the outputs switching in the same direction while driving identical loads.
- $t_{sk(pp)}$ is the magnitude of the difference in propagation delay times between any terminals of different devices switching in the same direction while operating at identical supply voltages, temperature, input signals and loads.

Shanghai Chipanalog Microelectronics Co., Ltd.

 $V_{DDA} = V_{DDB} = 2.5\text{ V} \pm 10\%$, $T_A = -40\text{ to }125^\circ\text{C}$ (over recommended operating conditions, unless otherwise specified)

PARAMETER		TEST CONDITIONS	MIN	TYP	MAX	UNIT		
DR	Data Rate				150	Mbps		
PW_{min}	Minimum Pulse Width				5	ns		
t_{PLH} , t_{PHL}	Propagation Delay Time	See Figure 8-1	5	12	16	ns		
PWD	Pulse Width Distortion $ t_{PLH} - t_{PHL} $						0.2	5
$t_{sk(o)}$	Channel-to-Channel Output Skew Time ¹	Same-direction channels		0.4	2.5	ns		
$t_{sk(pp)}$	Part-to Part Output Skew Time ²			1	5	ns		
t_r	Output Signal Rise Time	See Figure 8-1		2.5	4	ns		
t_f	Output Signal Fall Time	See Figure 8-1		2.5	4	ns		
t_{PHZ}	Disable Propagation Delay, High to High Impedance Output	See Figure 8-2			16	26	ns	
t_{PLZ}	Disable Propagation Delay, Low to High Impedance Output				16	26	ns	
t_{PZH}	Enable Propagation Delay, High Impedance to High Output			CA-IS374x L		10	20	ns
				CA-IS374x H		10	20	ns
t_{PZL}	Enable Propagation Delay, High Impedance to Low Output			CA-IS374x L		10	18	ns
				CA-IS374x H		10	20	ns
t_{DO}	Default Output Delay Time from Input Power Loss	See Figure 8-3		8	12	μs		
t_{SU}	Start-up Time			15	40	μs		

Notes:

1. $t_{sk(o)}$ is the skew between outputs of a single device with all driving inputs connected together and the outputs switching in the same direction while driving identical loads.
2. $t_{sk(pp)}$ is the magnitude of the difference in propagation delay times between any terminals of different devices switching in the same direction while operating at identical supply voltages, temperature, input signals and loads.

8. Parameter Measurement Information

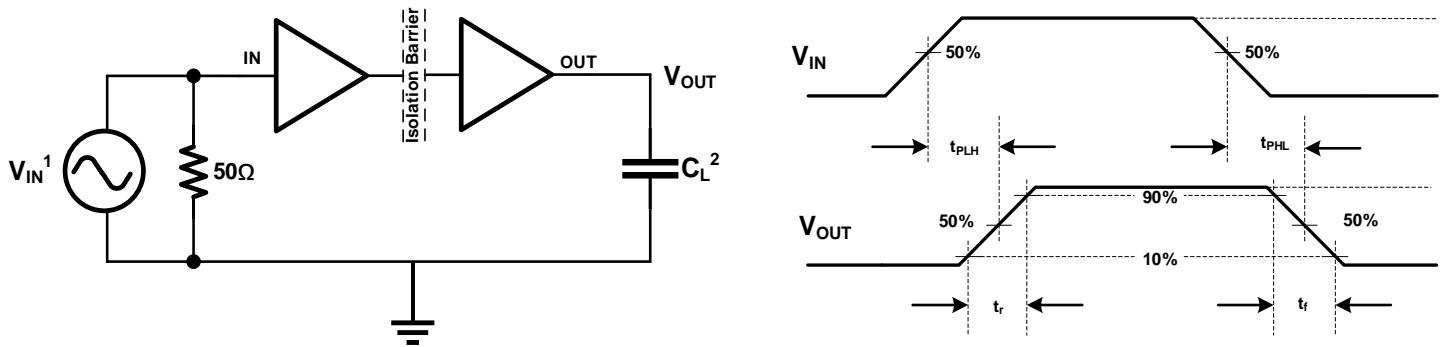

- Note:**
1. A square wave generator provide V_{IN} input signal with characteristics: frequency $\leq 100\text{kHz}$, 50% duty cycle, $t_r \leq 3\text{ns}$, $t_f \leq 3\text{ns}$, $Z_{out} = 50\Omega$. At the input, 50Ω resistor is required to terminate input generator signal. It is not needed in actual application.
 2. $C_L = 15\text{pF}$ and includes external circuit (instrumentation and fixture etc.) capacitance. Since the load capacitance influence the output rising time, it's a key factor in the timing characteristic measurement.

Figure 8-1. Switching Characteristics Test Circuit and Voltage Waveforms

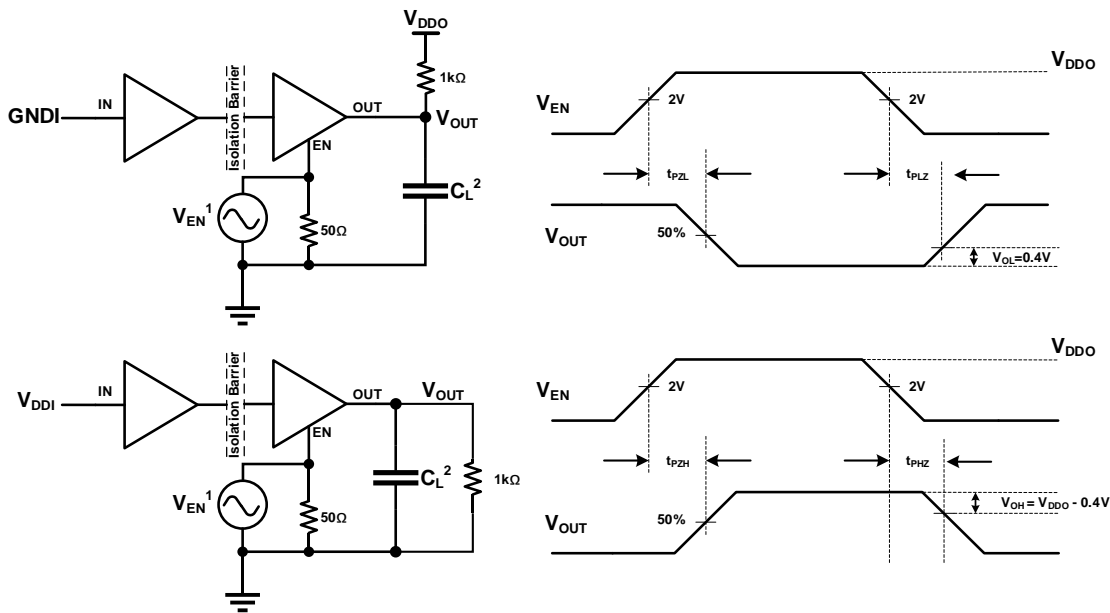

- Note:**
1. A square wave generator provide V_{IN} input signal with characteristics: frequency $\leq 10\text{kHz}$, 50% duty cycle, $t_r \leq 3\text{ns}$, $t_f \leq 3\text{ns}$, $Z_{out} = 50\Omega$. At the input, 50Ω resistor is required to terminate input generator signal. It is not needed in actual application.
 2. $C_L = 15\text{pF}$ and includes external circuit (instrumentation and fixture etc.) capacitance. Since the load capacitance influence the output rising time, it's a key factor in the timing characteristic measurement.

Figure 8-2. Enable/Disable Propagation Delay Time Test Circuit and Waveform

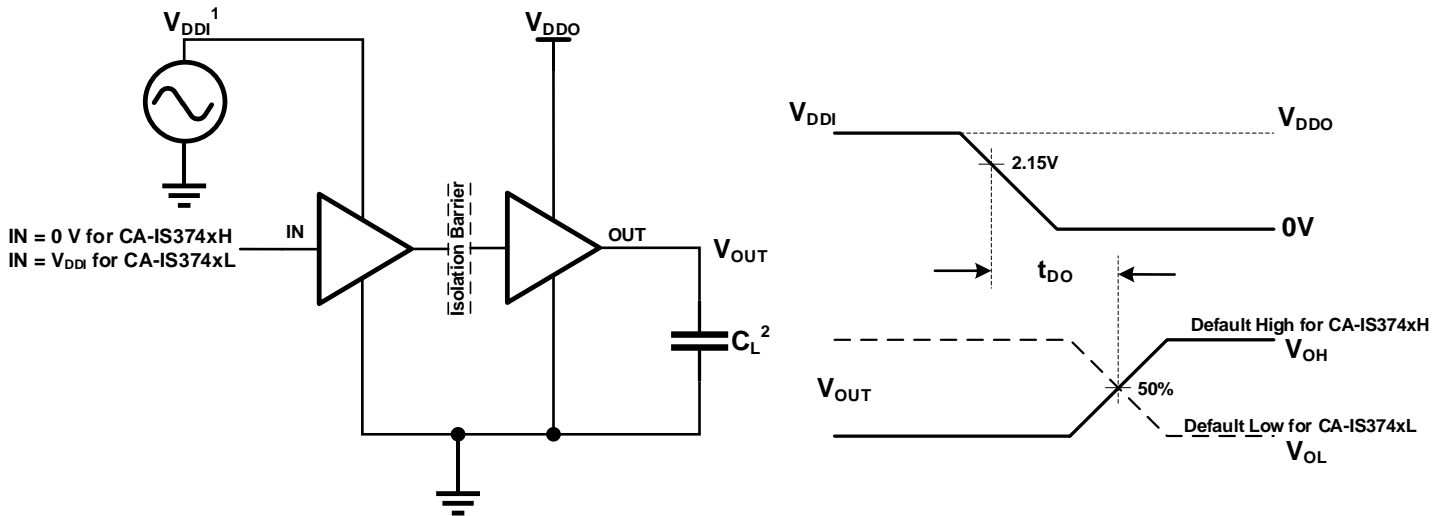
NOTE:

1. Power Supply Ramp Rate = 10 mV/ns. V_{DDI} should ramp over 2.375V, and less than 5.5V.
2. C_L = 15pF and includes external circuit (instrumentation and fixture etc.) capacitance. Since the load capacitance influence the output rising time, it's a key factor in the timing characteristic measurement.

Figure 8-3. Default Output Delay Time Test Circuit and Voltage Waveforms

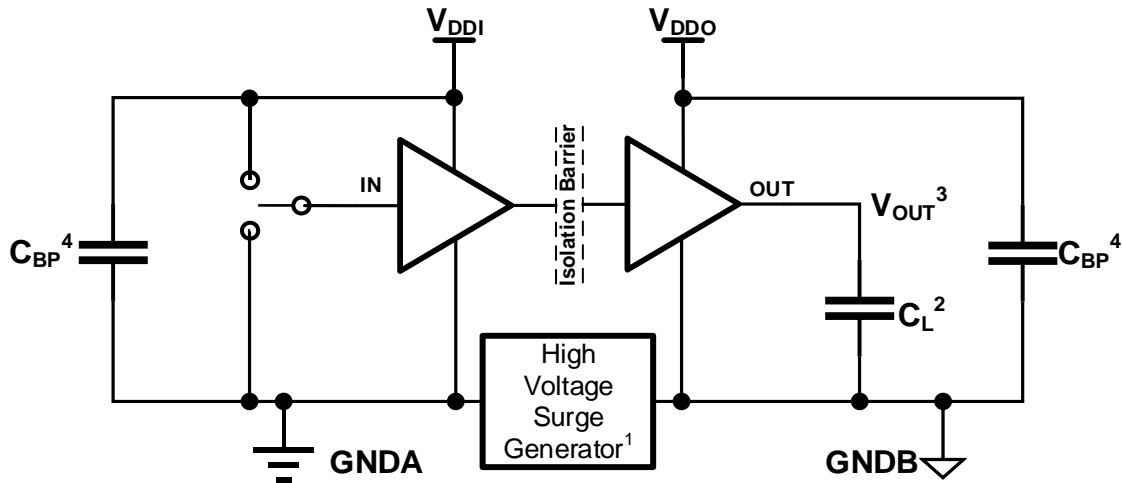
NOTE:

1. The High Voltage Surge Generator generates repetitive high voltage surges with > 1kV amplitude, rise time <10ns and fall time <10ns, to reach common-mode transient noise with > 150kV/ μ s slew rate.
2. C_L = 15pF and includes external circuit (instrumentation and fixture etc.) capacitance.
3. Pass-fail criteria: the output must remain stable.
4. C_{BP} (0.1 ~ 1uF) is bypass capacitance.

Figure 8-4. Common-Mode Transient Immunity Test Circuit

9. Detailed Description

9.1. Overview

The CA-IS374x devices are a family of automotive, four-channel digital galvanic isolators using Chipanalog's full differential capacitive isolation technology. These devices have an ON-OFF keying (OOK) modulation scheme to transfer digital signals across the SiO₂ based isolation barrier between circuits with different power domains. The transmitter sends a high frequency carrier across the barrier to represent one digital state and sends no signal to represent the other digital state. The receiver demodulates the signal and recovery input signal at output through a buffer stage. With this OOK architecture, CA-IS374x family of devices build a robust data transmission path between different power domains, without any special start-up initialization requirements. These devices also incorporate advanced full differential techniques to maximize the CMTI performance and minimize the radiated emissions due the high frequency carrier and I/O buffer switching.

9.2. Functional Block Diagram

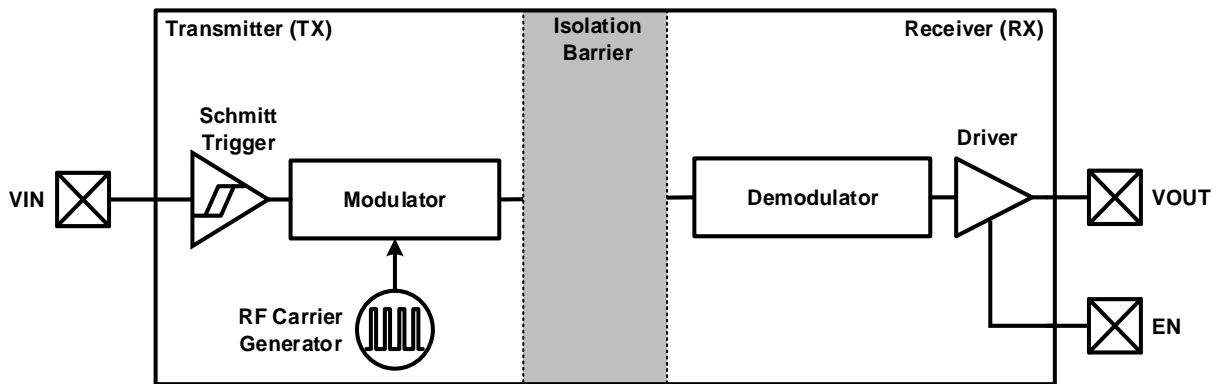

Figure 9-1. Functional Block Diagram of a Single Channel

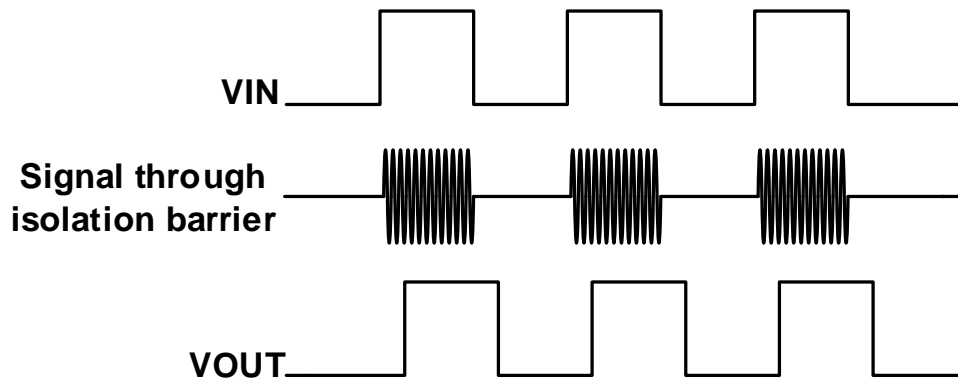

Figure 9-2. Conceptual Operation Waveforms of a Single Channel

9.3. Device Operation Modes

Table 9-1 lists the operation modes for the CA-IS374x devices.

Table 9-1. Operation Mode Table

V _{DDI} ¹	V _{DDO} ¹	INPUT (V _{Ix}) ²	ENABLE (EN _x) ³	OUTPUT (V _{Ox})	OPERATION
PU	PU	H	H or open	H	Normal operation mode: A channel output follows the logic state of its input.
		L	H or open	L	
		Open	H or open	Default	Default output mode: When input V _{Ix} is open, the corresponding channel output goes to its default logic state. Default is <i>High</i> for CA-IS374xH - Q1 and <i>Low</i> for CA-IS374xL .
X	PU	X	L	Z	High impedance mode: A low level of Enable pin causes the output to be high impedance.
PD	PU	X	H or open	Default	Default output mode: When V _{DDI} is unpowered, a channel output assumes the logic state based on its default option. Default is <i>High</i> for CA-IS374xH and <i>Low</i> for CA-IS374xL .
X	PD	X	X	Undetermined	If the output side V _{DDO} is unpowered, a channel output is undetermined. ⁴

Notes:

- V_{DDI} = Input-side V_{DD}; V_{DDO} = Output-side V_{DD}; PU = Powered up (V_{DD} ≥ V_{DD(UVLO+)}); PD = Powered down (V_{DD} ≤ V_{DD(UVLO-)}); X = Irrelevant; H = High level; L = Low level; Z = High Impedance.
- A strongly driven input signal can weakly power the floating V_{DD} through an internal protection diode and cause undetermined output.
- It is recommended to connect the enable inputs to external logic high or low level when the CA-IS374x operates in noisy environments.
- The outputs are in undetermined state when V_{DD(UVLO+)} < V_{DDI}, V_{DDO} < V_{DD(UVLO-)}.

Table 9-2 is the truth table with Enable input for the CA-IS374x devices.

Table 9-2. Enable Control

PART NUMBER	ENA ^{1,2}	ENB ^{1,2}	STATUS
CA-IS3740	—	H	B-side outputs VO1, VO2, VO3, VO4 are enabled and each output follows the logic state of its input.
	—	L	B-side outputs VO1, VO2, VO3, VO4 are disabled, and go to high impedance state.
CA-IS3741	H	X	A-side output VO4 is enabled and follows the logic state of its input.
	L	X	A-side output VO4 is disabled and goes to high impedance state.
	X	H	B-side outputs VO1, VO2, VO3 are enabled and each output follows the logic state of its input.
	X	L	B-side outputs VO1, VO2, VO3 are disabled and go to high impedance state.
CA-IS3742	H	X	A-side output VO3, VO4 are enabled and follows the logic state of its input.
	L	X	A-side output VO3, VO4 are disabled and goes to high impedance state.
	X	H	B-side outputs VO1, VO2 are enabled and each output follows the logic state of its input.
	X	L	B-side outputs VO1, VO2 are disabled and go to high impedance state.

Notes:

- Enable inputs ENA and ENB can be used to put the respective outputs in high impedance for multi master driving applications, external clock synchronization etc. With internal pull-up resistors, these pins can be connected to logic high or left floating to enable the outputs. If ENA, ENB are unused, it is recommended to connect these pins to a logic level, especially in the noisy environment.
- X = Irrelevant; H = High level; L = Low level.

10. Application and Implementation

The CA-IS374x isolation ICs provide complete galvanic isolation between two power domains, protecting circuits from high common-mode transients and faults and eliminating ground loops. In many applications, digital isolators are replacing optocouplers because they can reduce the power requirements and take up less board space while offering the same isolation capability. The CA-IS374x devices are the high-performance, four-channel digital isolators. These devices come with enable pins on each side which can be used to put the respective outputs in high impedance for multi master driving applications. Unlike optocouplers, which require external components to improve performance, provide bias, or limit current, the CA-IS374x devices only require two external bypass capacitors to operate. To reduce ripple and the chance of introducing data errors, bypass VDDA and VDDB pins with 0.1μF to 1μF low-ESR ceramic capacitors to GNDA and GNDB respectively. Place the bypass capacitors as close to the power supply input pins as possible.

Figure 10- 1 Typical Application Circuit of CA-IS3742

Figure 10- 1 shows typical operating circuit of the CA-IS3742; Figure 10- 2 is the typical applications for CA-IS37xx series products.

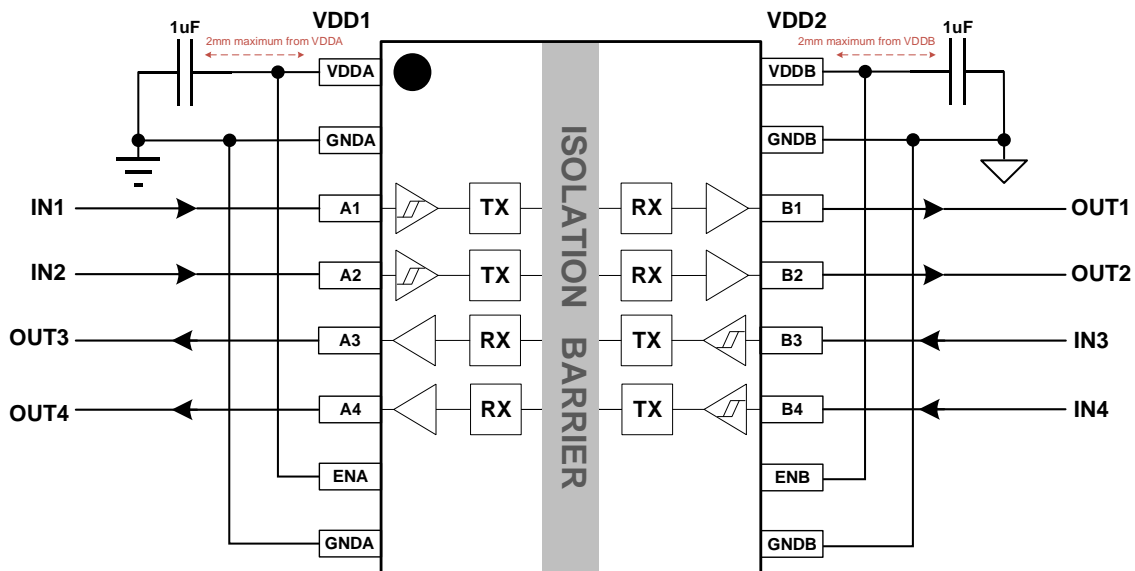

Figure 10- 1 Typical Application Circuit of CA-IS3742

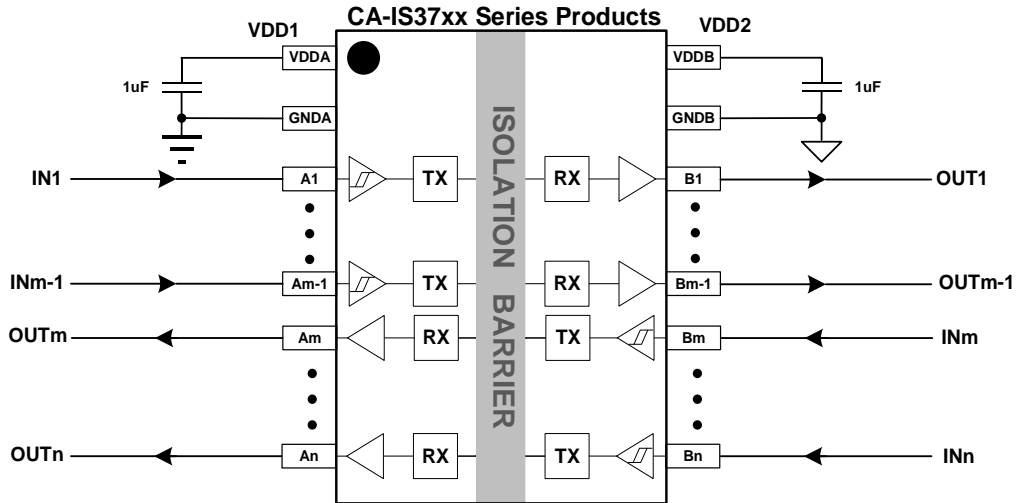
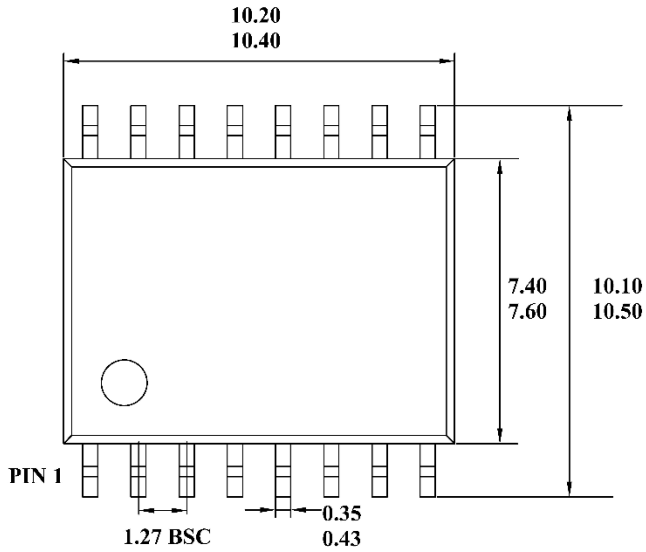

Figure 10- 2 Typical Applications for the CA-IS37xx Series Digital Isolators

11. Package Information

11.1. 16-Pin Wide Body SOIC Package Outline



TOP VIEW

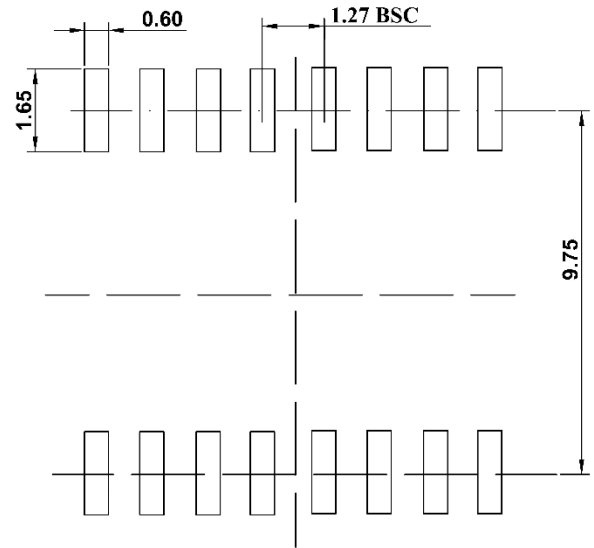

RECOMMENDED LAND PATTERN

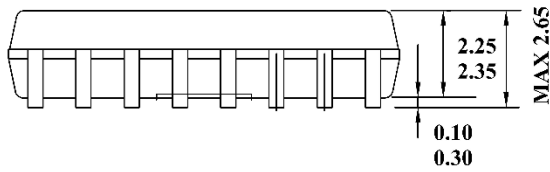

FRONT VIEW

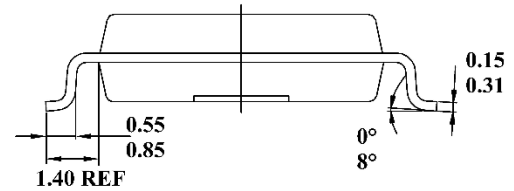

LEFT SIDE VIEW

Note:

1. All dimensions are in millimeters, angles are in degrees.

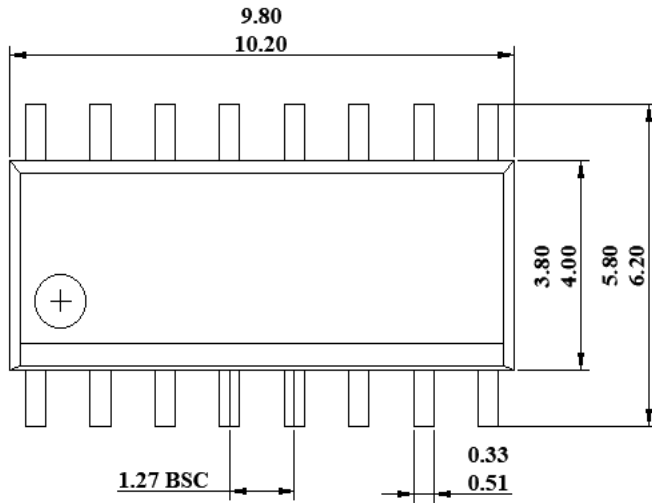
11.2. 16-Pin Narrow Body SOIC Package Outline

TOP VIEW

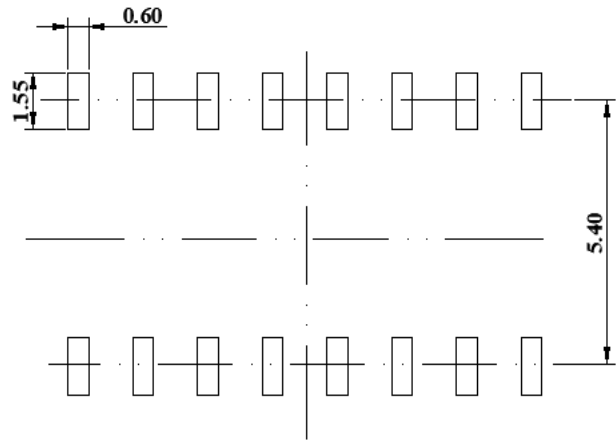

RECOMMENDED LAND PATTERN

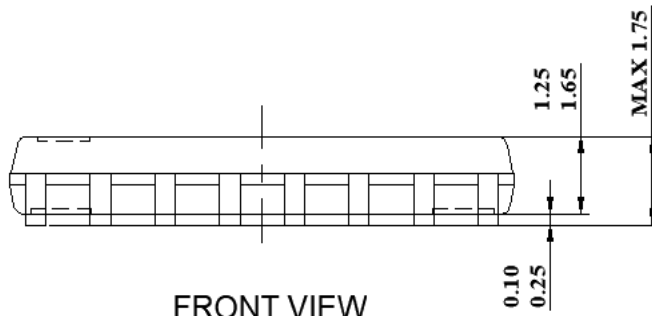

FRONT VIEW

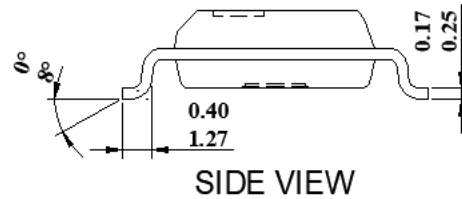

SIDE VIEW

Note:

1. All dimensions are in millimeters, angles are in degrees.

11.3. 16-Pin Narrow Body SSOP Package Outline

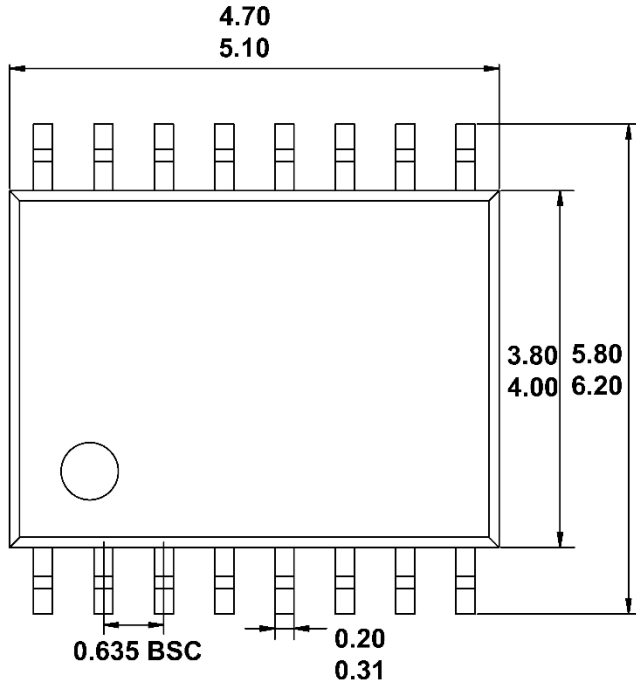

TOP VIEW

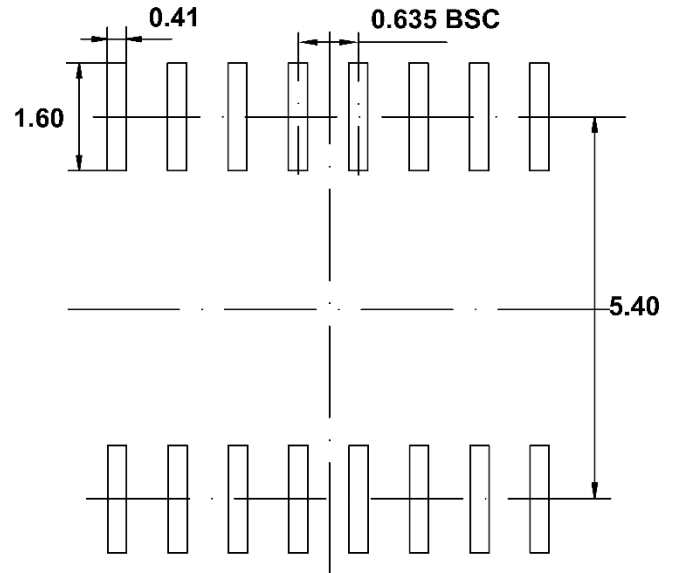

RECOMMENDED LAND PATTERN

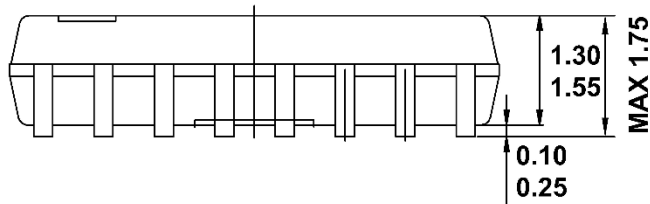

BOTTOM VIEW

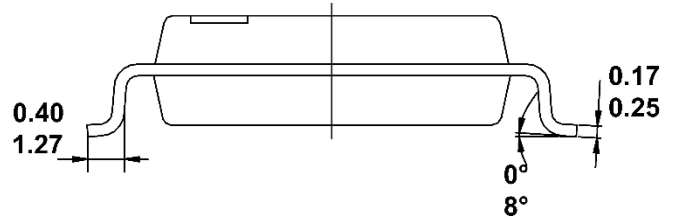

LEFT SIDE VIEW

Note:

1. All dimensions are in millimeters, angles are in degrees.

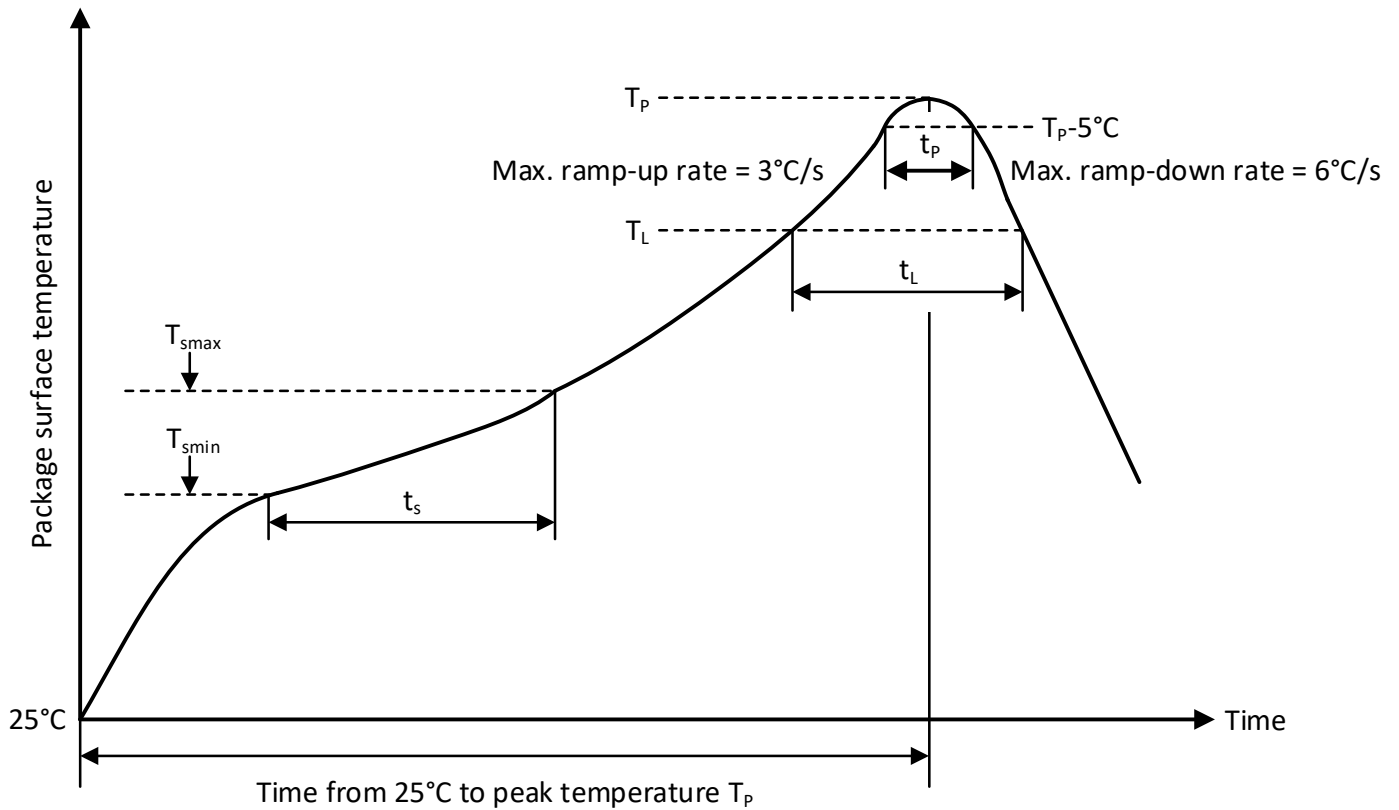
12. Soldering Temperature (reflow) Profile

Figure. 12-1 Soldering Temperature (reflow) Profile
Table 12-1 Soldering Temperature Parameter

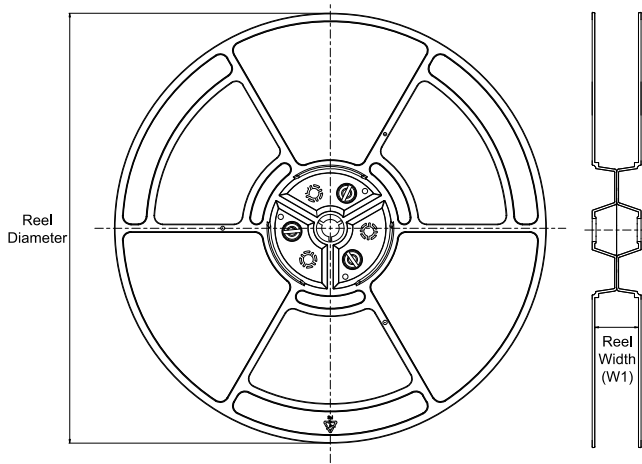
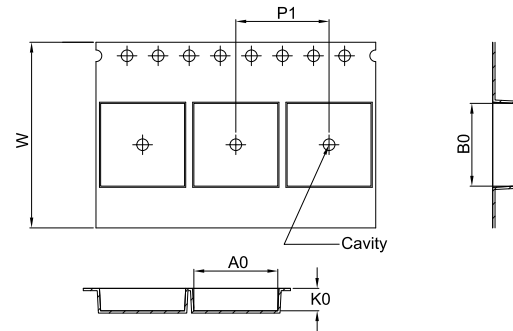
Profile Feature	Pb-Free Soldering
Ramp-up rate ($T_L = 217^\circ\text{C}$ to peak T_p)	3°C/s max
Time t_s of preheat temp ($T_{smin} = 150^\circ\text{C}$ to $T_{smax} = 200^\circ\text{C}$)	60~120 seconds
Time t_L to be maintained above 217°C	60~150 seconds
Peak temperature T_p	260°C
Time t_p within 5°C of actual peak temp	30 seconds max
Ramp-down rate (peak T_p to $T_L = 217^\circ\text{C}$)	6°C/s max
Time from 25°C to peak temperature T_p	8 minutes max

13. Tape and Reel Information
REEL DIMENSIONS

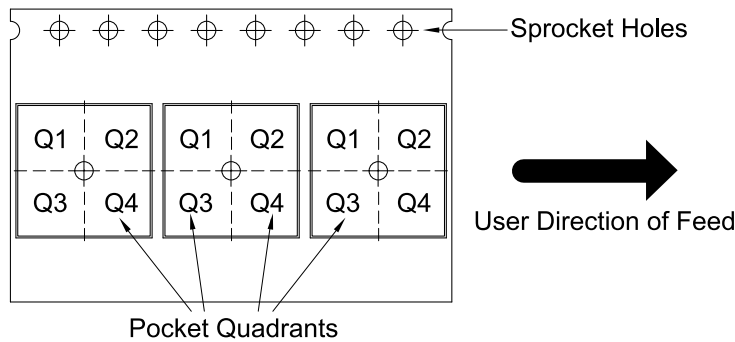
TAPE DIMENSIONS

A0	Dimension designed to accommodate the component width
B0	Dimension designed to accommodate the component length
K0	Dimension designed to accommodate the component thickness
W	Overall width of the carrier tape
P1	Pitch between successive cavity centers

QUADRANT ASSIGNMENTS FOR PIN 1 ORIENTATION IN TAPE

*All dimensions are nominal

Device	Package Type	Package Drawing	Pins	SPQ	Reel Diameter (mm)	Reel Width W1 (mm)	A0 (mm)	B0 (mm)	K0 (mm)	P1 (mm)	W (mm)	Pin1 Quadrant
CA-IS3740LN	SOIC	N	16	2500	330	16.4	6.40	10.30	2.10	8.00	16.00	Q1
CA-IS3740LW	SOIC	W	16	1000	330	16.4	10.90	10.70	3.20	12.00	16.00	Q1
CA-IS3740HN	SOIC	N	16	2500	330	16.4	6.40	10.30	2.10	8.00	16.00	Q1
CA-IS3740HW	SOIC	W	16	1000	330	16.4	10.90	10.70	3.20	12.00	16.00	Q1
CA-IS3741LN	SOIC	N	16	2500	330	16.4	6.40	10.30	2.10	8.00	16.00	Q1
CA-IS3741LW	SOIC	W	16	1000	330	16.4	10.90	10.70	3.20	12.00	16.00	Q1
CA-IS3741HN	SOIC	N	16	2500	330	16.4	6.40	10.30	2.10	8.00	16.00	Q1
CA-IS3741HW	SOIC	W	16	1000	330	16.4	10.90	10.70	3.20	12.00	16.00	Q1
CA-IS3742LN	SOIC	N	16	2500	330	16.4	6.40	10.30	2.10	8.00	16.00	Q1
CA-IS3742LW	SOIC	W	16	1000	330	16.4	10.90	10.70	3.20	12.00	16.00	Q1
CA-IS3742HN	SOIC	N	16	2500	330	16.4	6.40	10.30	2.10	8.00	16.00	Q1
CA-IS3742HW	SOIC	W	16	1000	330	16.4	10.90	10.70	3.20	12.00	16.00	Q1
CA-IS3741LB	SSOP	B	16	2500	330	12.4	6.40	5.40	2.10	8.00	12.00	Q1
CA-IS3741HB	SSOP	B	16	2500	330	12.4	6.40	5.40	2.10	8.00	12.00	Q1
CA-IS3742LB	SSOP	B	16	2500	330	12.4	6.40	5.40	2.10	8.00	12.00	Q1
CA-IS3742HB	SSOP	B	16	2500	330	12.4	6.40	5.40	2.10	8.00	12.00	Q1
CA-IS3740LB	SSOP	B	16	2500	330	12.4	6.40	5.40	2.10	8.00	12.00	Q1
CA-IS3740HB	SSOP	B	16	2500	330	12.4	6.40	5.40	2.10	8.00	12.00	Q1

14. Important Statement

The above information is for reference only and used for helping Chipanalog customers with design, research and development. Chipanalog reserves the rights to change the above information due to technological innovation without advance notice.

All Chipanalog products pass ex-factory test. As for specific practical applications, customers need to be responsible for evaluating and determining whether the products are applicable or not by themselves. Chipanalog's authorization for customers to use the resources are only limited to development of the related applications of the Chipanalog products. In addition to this, the resources cannot be copied or shown, and Chipanalog is not responsible for any claims, compensations, costs, losses, liabilities and the like arising from the use of the resources.

Trademark information

Chipanalog Inc.® and Chipanalog® are registered trademarks of Chipanalog.



<http://www.chipanalog.com>