

CA-IS384x High-Performance Reinforced Quad-Channel Digital Isolators

1 Key Features

- Signal Rate: DC to 150Mbps
- Wide Operating Supply Voltage: 2.5V to 5.5V
- Wide Operating Temperature Range: -40°C to 125°C
- No Start-Up Initialization Required
- Default Output High and Low Options
- High Electromagnetic Immunity
- High CMTI: $\pm 150\text{kV}/\mu\text{s}$ (Typical)
- Low Power Consumption (Typical):
 - 1.5mA per Channel at 1Mbps with 5.0V Supply
 - 6.6mA per Channel at 100Mbps with 5.0V Supply
- Precise Timing (Typical)
 - 12ns Propagation Delay
 - 1ns Pulse Width Distortion
 - 2ns Propagation Delay Skew
 - 5ns Minimum Pulse Width
- Isolation Rating up to 5.7kVrms (wide body package)
- Isolation Rating up to 7.5kVrms (extra wide body package)
- ESD: $\pm 8\text{kV}$ HBM
- Isolation Barrier Life: >40 Years
- Tri-state Outputs with ENABLE
- Schmitt Trigger Inputs
- RoHS-Compliant Packages
 - SOIC16 Wide Body
 - SOIC16 Extra Wide Body

2 Applications

- Solar Inverter
- Wind-Generated Electricity
- High Voltage Power Storage
- High Voltage Grid System
- EV Charging Station
- Medical Electronics

3 Description

The CA-IS384x devices are high-performance quad-channel digital isolators with precise timing characteristics and low power consumption. The CA-IS384x devices provide high electromagnetic immunity and low emissions, while isolating CMOS digital I/Os. All device versions have Schmitt

trigger input for high noise immunity. Each isolation channel consists of a transmitter and a receiver separated by silicon dioxide (SiO_2) insulation barrier. The CA-IS3840 device has all four channels in the same direction with output enable on the output side (B side), the CA-IS3841 device has three forward and one reverse-direction channels with output enable on both sides, the CA-IS3842 device has two forward and two reverse-direction channels with output enable on both sides. All devices have fail-safe mode option. If the input power or signal is lost, default output is low for devices with suffix L and high for devices with suffix H.

CA-IS384x devices has high insulation capability to handle noise and surge on a data bus or other circuits from entering the local ground and interfering with or damaging sensitive circuitry. High CMTI ability promises the correct transmission of digital signal. The CA-IS384x devices are available in 16-pin wide body SOIC packages. Products support insulation withstanding up to 5.7kVrms (wide body) and 7.5kVrms (extra wide body)

Device Information

PART NUMBER	PACKAGE	BODY SIZE(NOM)
CA-IS3840, CA-IS3841, CA-IS3842	SOIC16-WB(W)	10.30 mm × 7.50 mm
	SOIC16-WWB(WW)	10.30 mm × 14.00 mm

Simplified Channel Structure

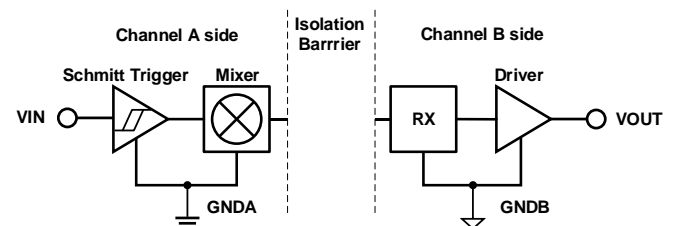

Channel A side and B side are separated by isolation capacitors. GNDA and GNDB are the isolated ground for signals and supplies of A side and B side respectively.

4 Ordering Guide

Table 4-1 Ordering Guide for Valid Ordering Part Number

Ordering Part Number	Number of Inputs A Side	Number of Inputs B Side	Default Output	Isolation Rating (kV _{RMS})	Output Enable	Package
CA-IS3840LW	4	0	Low	5.7	Yes	SOIC16-WB
CA-IS3840HW	4	0	High	5.7	Yes	SOIC16-WB
CA-IS3841LW	3	1	Low	5.7	Yes	SOIC16-WB
CA-IS3841HW	3	1	High	5.7	Yes	SOIC16-WB
CA-IS3842LW	2	2	Low	5.7	Yes	SOIC16-WB
CA-IS3842HW	2	2	High	5.7	Yes	SOIC16-WB
CA-IS3840LWW	4	0	Low	7.5	Yes	SOIC16-WWB
CA-IS3840HWW	4	0	High	7.5	Yes	SOIC16-WWB
CA-IS3841LWW	3	1	Low	7.5	Yes	SOIC16-WWB
CA-IS3841HWW	3	1	High	7.5	Yes	SOIC16-WWB
CA-IS3842LWW	2	2	Low	7.5	Yes	SOIC16-WWB
CA-IS3842HWW	2	2	High	7.5	Yes	SOIC16-WWB

Table of Contents

1	Key Features	1		
2	Applications	1		
3	Description	1		
4	Ordering Guide	2		
5	Revision History	3		
6	PIN Descriptions and Functions	4		
7	Specifications.....	5		
7.1	Absolute Maximum Ratings ¹	5		
7.2	ESD Ratings.....	5		
7.3	Recommended Operating Conditions	5		
7.4	Thermal Information	6		
7.5	Power Rating	6		
7.6	Insulation Specifications.....	7		
7.7	Safety-Related Certifications	8		
7.8	Electrical Characteristics	9		
7.8.1	$V_{DDA} = V_{DDB} = 5\text{ V} \pm 10\%$, $T_A = -40^\circ\text{C}$ to 125°C	9		
7.8.2	$V_{DDA} = V_{DDB} = 3.3\text{ V} \pm 10\%$, $T_A = -40^\circ\text{C}$ to 125°C	9		
7.8.3	$V_{DDA} = V_{DDB} = 2.5\text{ V} \pm 5\%$, $T_A = -40^\circ\text{C}$ to 125°C	9		
7.9	Supply Current Characteristics	10		
7.9.1	$V_{DDA} = V_{DDB} = 5\text{ V} \pm 10\%$, $T_A = -40^\circ\text{C}$ to 125°C	10		
7.9.2	$V_{DDA} = V_{DDB} = 3.3\text{ V} \pm 10\%$, $T_A = -40^\circ\text{C}$ to 125°C	11		
7.9.3	$V_{DDA} = V_{DDB} = 2.5\text{ V} \pm 5\%$, $T_A = -40^\circ\text{C}$ to 125°C	12		
7.10	Timing Characteristics.....	13		
7.10.1	$V_{DDA} = V_{DDB} = 5\text{ V} \pm 10\%$, $T_A = -40^\circ\text{C}$ to 125°C	13		
7.10.2	$V_{DDA} = V_{DDB} = 3.3\text{ V} \pm 10\%$, $T_A = -40^\circ\text{C}$ to 125°C	13		
7.10.3	$V_{DDA} = V_{DDB} = 2.5\text{ V} \pm 5\%$, $T_A = -40^\circ\text{C}$ to 125°C	14		
8	Parameter Measurement Information.....	15		
9	Detailed Description	17		
9.1	Theory of Operation	17		
9.2	Functional Block Diagram	17		
9.3	Device Operation Modes	18		
10	Application and Implementation.....	19		
11	Package Information	20		
11.1	16-Pin Wide Body SOIC Package(10.30 mm × 7.50 mm)	20		
11.2	16-Pin Wide Body SOIC Package(10.30 mm × 14.00 mm)	21		
12	Soldering Information	22		
13	Tape And Reel Information.....	23		
14	Important Notice	24		

5 Revision History

Revision Number	Description	Page Changed
Version 1.00	N/A	N/A
Version 1.01	Update UL certification information	8
Version 1.02	Update UL and TUV certification information	8
Version 1.03	Update Isolated information	7
Version 1.04	1. Update VDE certification information 2. Update Tape and reel information	8 23
Version 1.05	Update insulation specifications	7

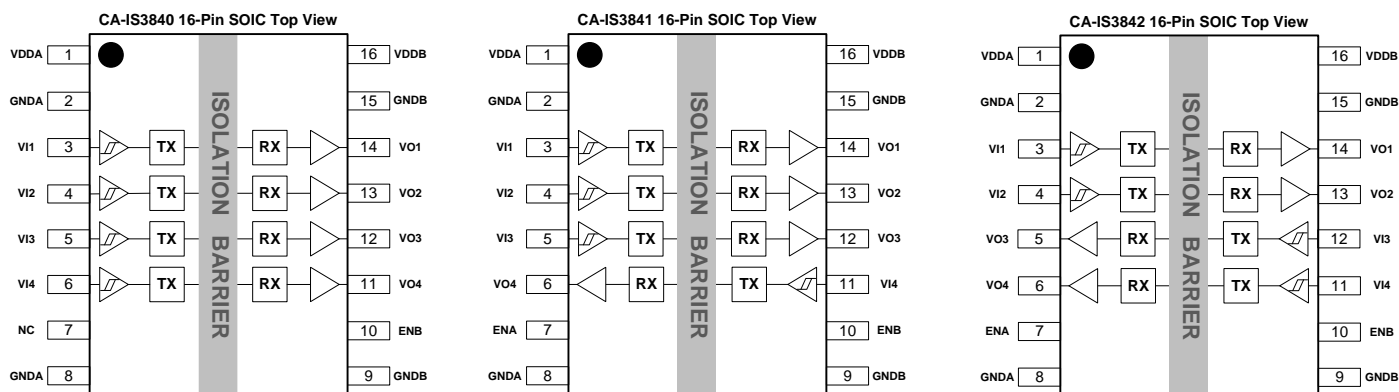
6 PIN Descriptions and Functions

Figure 6-1 CA-IS384x Top View
Table 6-1 CA-IS384x Pin Description and Functions

Name	SOIC16 Pin#	Type	Description
VDDA	1	Supply	Side A Power Supply
GNDA	2	Ground	Side A Ground
VI1	3	Digital Input	Side A Digital Input
VI2	4	Digital Input	Side A Digital Input
VI3/VO3	5	Digital I/O	Side A Digital Input for CA-IS3840/41 or Output for CA-IS3842
VI4/VO4	6	Digital I/O	Side A Digital Input for CA-IS3840 or Output for CA-IS3841/42
NC ¹ /ENA ²	7	Digital Input	Side A Active High or Floating Enable. NC for CA-IS3840
GNDA	8	Ground	Side A Ground
GNDB	9	Ground	Side B Ground
ENB ²	10	Digital Input	Side B Active High or Floating Enable.
VI4/VO4	11	Digital I/O	Side B Digital Input for CA-IS3841/42 or Output for CA-IS3840
VI3/VO3	12	Digital I/O	Side B Digital Input for CA-IS3842 or Output for CA-IS3840/41
VO2	13	Digital Output	Side B Digital Output
VO1	14	Digital Output	Side B Digital Output
GNDB	15	Ground	Side B Ground
VDDDB	16	Supply	Side B Power Supply

Note:

- No Connect. These pins are not internally connected. They can be left floating, tied to VDD or tied to GND
- Enable inputs ENA and ENB can be used for multiplexing, for clock sync, or other output control. ENA, ENB logic operation is summarized for each isolator product in Table 9-2. These inputs are internally pulled-up to local VDD allowing them to be connected to an external logic level (high or low) or left floating. To minimize noise coupling, do not connect circuit traces to ENA or ENB if they are left floating. If ENA, ENB are unused, it is recommended they be connected to an external logic level, especially if the CA-IS384x is operating in a noisy environment.

7 Specifications

7.1 Absolute Maximum Ratings¹

		MIN	MAX	UNIT
V _{DDA} , V _{DDB}	Supply Voltage ²	-0.5	6.0	V
V _{in}	Voltage at Ax, Bx, ENx	-0.5	V _{DDA} +0.5 ³	V
I _O	Output Current	-20	20	mA
T _J	Junction Temperature		150	°C
T _{STG}	Storage Temperature	-65	150	°C

NOTE:

- Stresses beyond those listed under *Absolute Maximum Ratings* may cause permanent damage to the device. These are stress ratings only and functional operation of the device at these or any other conditions beyond those indicated under *Recommended Operating Conditions* is not implied. Exposure to absolute-maximum-rated conditions for extended periods may affect device reliability.
- All voltage values except differential I/O bus voltages are with respect to the local ground terminal (GNDA or GNDB) and are peak voltage values.
- Maximum voltage must not exceed 6 V.

7.2 ESD Ratings

		VALUE	UNIT
V _{ESD} Electrostatic discharge	Human body model (HBM), per ANSI/ESDA/JEDEC JS-001, to the Pins on the same side ¹	±8000	V
	Charged device model (CDM), per JEDEC specification JESD22-C101, all pins ²	±2000	

NOTE:

- JEDEC document JEP155 states that 500-V HBM allows safe manufacturing with a standard ESD control process.
- JEDEC document JEP157 states that 250-V CDM allows safe manufacturing with a standard ESD control process.

7.3 Recommended Operating Conditions

		MIN	TYP	MAX	UNIT
V _{DDA} , V _{DDB}	Supply Voltage	2.375		5.5	V
V _{DD} (UVLO+)	VDD Undervoltage Threshold When Supply Voltage is Rising	1.95	2.24	2.375	V
V _{DD} (UVLO-)	VDD Undervoltage Threshold When Supply Voltage is Falling	1.88	2.10	2.325	V
V _{HYS} (UVLO)	VDD Undervoltage Threshold Hysteresis	70	140	250	mV
I _{OH}	High-level Output Current	V _{DDO} ¹ = 5V		-4	mA
		V _{DDO} = 3.3V		-2	
		V _{DDO} = 2.5V		-1	
I _{OL}	Low-level Output Current	V _{DDO} = 5V		4	mA
		V _{DDO} = 3.3V		2	
		V _{DDO} = 2.5V		1	
V _{IH}	High-level Input Voltage	2.0			V
V _{IL}	Low-level Input Voltage			0.8	V
DR	Data Rate	0		150	Mbps
T _A	Ambient Temperature	-40	27	125	°C

NOTE:

- V_{DDO} = Output-side V_{DD}

7.4 Thermal Information

THERMAL METRIC		CA-IS384x		UNIT
		W	WW	
$R_{\theta JA}$	Junction-to-ambient thermal resistance	83.4	83.4	°C/W

7.5 Power Rating

PARAMETER		TEST CONDITIONS	MIN	TYP	MAX	UNIT
CA-IS3840						
P_D	Maximum Power Dissipation	$V_{DDA} = V_{DDB} = 5.5\text{ V}$, $C_L = 15\text{ pF}$,			334	mW
P_{DA}	Maximum Power Dissipation on Side-A	$T_J = 150^\circ\text{C}$, Input a 75-MHz 50% duty			36	mW
P_{DB}	Maximum Power Dissipation on Side-B	cycle square wave			298	mW
CA-IS3841						
P_D	Maximum Power Dissipation	$V_{DDA} = V_{DDB} = 5.5\text{ V}$, $C_L = 15\text{ pF}$,			334	mW
P_{DA}	Maximum Power Dissipation on Side-A	$T_J = 150^\circ\text{C}$, Input a 75-MHz 50% duty			100	mW
P_{DB}	Maximum Power Dissipation on Side-B	cycle square wave			234	mW
CA-IS3842						
P_D	Maximum Power Dissipation	$V_{DDA} = V_{DDB} = 5.5\text{ V}$, $C_L = 15\text{ pF}$,			334	mW
P_{DA}	Maximum Power Dissipation on Side-A	$T_J = 150^\circ\text{C}$, Input a 75-MHz 50% duty			167	mW
P_{DB}	Maximum Power Dissipation on Side-B	cycle square wave			167	mW

7.6 Insulation Specifications

PARAMETR		TEST CONDITIONS	VALUE		UNIT
			W	WW	
CLR	External clearance ¹	Shortest terminal-to-terminal distance through air	>8	>15	mm
CPG	External creepage ¹	Shortest terminal-to-terminal distance across the package surface	>8	>15	mm
DTI	Distance through the insulation	Minimum internal gap (internal clearance)	28		μm
CTI	Comparative tracking index	DIN EN 60112 (VDE 0303-11); IEC 60112	>600		V
	Material group	According to IEC 60664-1	I		
	Overvoltage category per IEC 60664-1	Rated mains voltage ≤ 300 V _{RMS}	I-IV	I-IV	
		Rated mains voltage ≤ 600 V _{RMS}	I-IV	I-IV	
		Rated mains voltage ≤ 1000 V _{RMS}	I-III	I-IV	
DIN V VDE V 0884-17:2021-10²					
V _{IORM}	Maximum repetitive peak isolation voltage	AC voltage (bipolar)	2121	2828	V _{PK}
V _{IOWM}	Maximum working isolation voltage	AC voltage; Time dependent dielectric breakdown (TDDB) Test	1500	2000	V _{RMS}
		DC voltage	2121	2828	V _{DC}
V _{IOTM}	Maximum transient isolation voltage	V _{TEST} = V _{IOTM} , t = 60 s (qualification); V _{TEST} = 1.2 × V _{IOTM} , t = 1 s (100% production)	8000		V _{PK}
V _{IOSM}	Maximum surge isolation voltage ³	Test method per IEC 60065, 1.2/50 μs waveform, V _{TEST} = 1.6 × V _{IOSM} (qualification)	8000		V _{PK}
Q _{pd}	Apparent charge ⁴	Method a, After Input/Output safety test subgroup 2/3, V _{ini} = V _{IOTM} , t _{ini} = 60 s; V _{pd(m)} = 1.2 × V _{IORM} , t _m = 10 s	≤5		pC
		Method a, After environmental tests subgroup 1, V _{ini} = V _{IOTM} , t _{ini} = 60 s; V _{pd(m)} = 1.6 × V _{IORM} , t _m = 10 s	≤5		
		Method b1, At routine test (100% production) and preconditioning (type test) V _{ini} = 1.2 × V _{IOTM} , t _{ini} = 1 s; V _{pd(m)} = 1.875 × V _{IORM} , t _m = 1 s	≤5		
C _{IO}	Barrier capacitance, input to output ⁵	V _{IO} = 0.4 × sin(2πft), f = 1 MHz	~2		pF
R _{IO}	Isolation resistance ⁵	V _{IO} = 500 V, T _A = 25°C	>10 ¹²		Ω
		V _{IO} = 500 V, 100°C ≤ T _A ≤ 125°C	>10 ¹¹		
		V _{IO} = 500 V at T _S = 150°C	>10 ⁹		
	Pollution degree		2		
UL 1577					
V _{ISO}	Maximum withstanding isolation voltage	V _{TEST} = V _{ISO} , t = 60 s (qualification), V _{TEST} = 1.2 × V _{ISO} , t = 1 s (100% production)	5700	7500	V _{RMS}
NOTE:					
1. Creepage and clearance requirements should be applied according to the specific equipment isolation standards of an application. Care should be taken to maintain the creepage and clearance distance of a board design to ensure that the mounting pads of the isolator on the printed-circuit board do not reduce this distance. Creepage and clearance on a printed-circuit board become equal in certain cases. Techniques such as inserting grooves and/or ribs on a printed circuit board are used to help increase these specifications.					
2. This coupler is suitable for safe electrical insulation only within the safety ratings. Compliance with the safety ratings shall be ensured by means of suitable protective circuits.					
3. Testing is carried out in air or oil to determine the intrinsic surge immunity of the isolation barrier.					
4. Apparent charge is electrical discharge caused by a partial discharge (pd).					
5. All pins on each side of the barrier tied together creating a two-terminal device.					

7.7 Safety-Related Certifications

VDE	UL	TUV
Recognized under DIN V VDE V 0884-17:2021-10	Recognized under UL 1577 Component Recognition Program	Recognized under EN 61010-1:2010+A1
Maximum transient isolation voltage: 8000V _{pk} (SOIC16-WB) and 8000V _{pk} (SOIC16-WWB) Maximum repetitive peak isolation voltage: 2121V _{pk} (SOIC16-WB) and 2828V _{pk} (SOIC16-WWB) Maximum surge isolation voltage: 8000V _{pk} (SOIC16-WB) and 8000V _{pk} (SOIC16-WWB)	SOIC16-WB: 5700 V _{RMS} SOIC16-WWB: 7500 V _{RMS}	SOIC16-WB: 5700 V _{RMS} SOIC16-WWB: 5700 V _{RMS}
Certification Number: 40057278	Certification Number: E511334	Certification Number: CN23RC4J 001

7.8 Electrical Characteristics

7.8.1 $V_{DDA} = V_{DDB} = 5\text{ V} \pm 10\%$, $T_A = -40^\circ\text{C}$ to 125°C

PARAMETER		TEST CONDITIONS	MIN	TYP	MAX	UNIT
V_{OH}	High-level Output Voltage	$I_{OH} = -4\text{mA}$; <i>See Figure 8-2</i>	$V_{DDO}^{1-0.4}$	4.8		V
V_{OL}	Low-level Output Voltage	$I_{OL} = 4\text{mA}$; <i>See Figure 8-2</i>		0.2	0.4	V
$V_{IT+(IN)}$	Positive-going Input Logic High		2			V
$V_{IT-(IN)}$	Negative-going Input Logic Low				0.8	V
$V_{IT+(EN)}$	EN Pin input Logic High		$0.7 \cdot V_{DD}$			V
$V_{IT-(EN)}$	EN Pin input Logic Low				$0.3 \cdot V_{DD}$	V
I_{IH}	High-Level Input Leakage Current	$V_{IH} = V_{DDA}$ at Ax or Bx or ENx			20	μA
I_{IL}	Low-Level Input Leakage Current	$V_{IL} = 0\text{ V}$ at Ax or Bx	-20			μA
Z_O	Output Impedance ²			50		Ω
CMTI	Common-mode Transient Immunity	$V_I = V_{DDI}^1$ or 0 V, $V_{CM} = 1200\text{ V}$; <i>See Figure 8-4</i>	100	150		$\text{kV}/\mu\text{S}$
C_I	Input Capacitance ³	$V_I = V_{DD}/2 + 0.4 \cdot \sin(2\pi ft)$, $f = 1\text{ MHz}$, $V_{DD} = 5\text{ V}$		2		pF

NOTE:

- V_{DDI} = Input-side V_{DD} , V_{DDO} = Output-side V_{DD}
- The nominal output impedance of an isolator driver channel is approximately $50\ \Omega \pm 40\%$.
- Measured from pin to Ground.

7.8.2 $V_{DDA} = V_{DDB} = 3.3\text{ V} \pm 10\%$, $T_A = -40^\circ\text{C}$ to 125°C

PARAMETER		TEST CONDITIONS	MIN	TYP	MAX	UNIT
V_{OH}	High-level Output Voltage	$I_{OH} = -2\text{mA}$; <i>See Figure 8-2</i>	$V_{DDO}^{1-0.2}$	3.1		V
V_{OL}	Low-level Output Voltage	$I_{OL} = 2\text{mA}$; <i>See Figure 8-2</i>		0.2	0.4	V
$V_{IT+(IN)}$	Positive-going Input Logic High		2			V
$V_{IT-(IN)}$	Negative-going Input Logic Low				0.8	V
$V_{IT+(EN)}$	EN Pin input Logic High		$0.7 \cdot V_{DD}$			V
$V_{IT-(EN)}$	EN Pin input Logic Low				$0.3 \cdot V_{DD}$	V
I_{IH}	High-Level Input Leakage Current	$V_{IH} = V_{DDA}$ at Ax or Bx or ENx			20	μA
I_{IL}	Low-Level Input Leakage Current	$V_{IL} = 0\text{ V}$ at Ax or Bx	-20			μA
Z_O	Output Impedance ²			50		Ω
CMTI	Common-mode Transient Immunity	$V_I = V_{DDI}^1$ or 0 V, $V_{CM} = 1200\text{ V}$; <i>See Figure 8-4</i>		100	150	$\text{kV}/\mu\text{s}$
C_I	Input Capacitance ³	$V_I = V_{DD}/2 + 0.4 \cdot \sin(2\pi ft)$, $f = 1\text{ MHz}$, $V_{DD} = 3.3\text{ V}$		2		pF

NOTE:

- V_{DDI} = Input-side V_{DD} , V_{DDO} = Output-side V_{DD}
- The nominal output impedance of an isolator driver channel is approximately $50\ \Omega \pm 40\%$.
- Measured from pin to Ground.

7.8.3 $V_{DDA} = V_{DDB} = 2.5\text{ V} \pm 5\%$, $T_A = -40^\circ\text{C}$ to 125°C

PARAMETER		TEST CONDITIONS	MIN	TYP	MAX	UNIT
V_{OH}	High-level Output Voltage	$I_{OH} = -1\text{mA}$; <i>See Figure 8-2</i>	$V_{DDO}^{1-0.4}$	2.3		V
V_{OL}	Low-level Output Voltage	$I_{OL} = 1\text{mA}$; <i>See Figure 8-2</i>		0.2	0.4	V
$V_{IT+(IN)}$	Positive-going Input Logic High		2			V
$V_{IT-(IN)}$	Negative-going Input Logic Low				0.8	V
$V_{IT+(EN)}$	EN Pin input Logic High		$0.7 \cdot V_{DD}$			V
$V_{IT-(EN)}$	EN Pin input Logic Low				$0.3 \cdot V_{DD}$	V
I_{IH}	High-Level Input Leakage Current	$V_{IH} = V_{DDA}$ at Ax or Bx or ENx			20	μA
I_{IL}	Low-Level Input Leakage Current	$V_{IL} = 0\text{ V}$ at Ax or Bx	-20			μA
Z_O	Output Impedance ²			50		Ω
CMTI	Common-mode Transient Immunity	$V_I = V_{DDI}^1$ or 0 V, $V_{CM} = 1200\text{ V}$; <i>See Figure 8-4</i>	100	150		$\text{kV}/\mu\text{S}$
C_I	Input Capacitance ³	$V_I = V_{DD}/2 + 0.4 \cdot \sin(2\pi ft)$, $f = 1\text{ MHz}$, $V_{DD} = 2.5\text{ V}$		2		pF

NOTE:

- V_{DDI} = Input-side V_{DD} , V_{DDO} = Output-side V_{DD}
- The nominal output impedance of an isolator driver channel is approximately $50\ \Omega \pm 40\%$.
- Measured from pin to Ground.

7.9 Supply Current Characteristics
7.9.1 $V_{DDA} = V_{DDB} = 5 V \pm 10\%$, $T_A = -40^{\circ}C$ to $125^{\circ}C$

PARAMETER	TEST CONDITION	SUPPLY CURRENT	MIN	TYP	MAX	UNIT
CA-IS3840						
Supply Current – Disable	ENB = 0 V; $V_{IN} = 0V$ (CA-IS3840L); $V_{IN} = V_{DDA}$ (CA-IS3840H)	I_{DDA}	1.3	2.1	mA	
		I_{DDB}	2.5	3.5		
	ENB = 0 V; $V_{IN} = V_{DDA}$ (CA-IS3840L); $V_{IN} = 0V$ (CA-IS3840H)	I_{DDA}	6.4	9.5		
		I_{DDB}	2.7	3.6		
Supply Current – DC Signal	ENB = V_{DDB} ; $V_{IN} = 0V$ (CA-IS3840L); $V_{IN} = V_{DDA}$ (CA-IS3840H)	I_{DDA}	1.3	2.1		
		I_{DDB}	2.7	3.9		
	ENB = V_{DDB} ; $V_{IN} = V_{DDA}$ (CA-IS3840L); $V_{IN} = 0V$ (CA-IS3840H)	I_{DDA}	6.4	9.5		
		I_{DDB}	2.7	4.0		
Supply Current – AC Signal	ENB = V_{DDB} ; All Channels Switching with 50% Duty Cycle Square Wave Clock Input with 5V Amplitude; $C_L = 15$ pF for Each Channel	1Mbps (500kHz)	I_{DDA}	3.9	5.8	
		10Mbps (5MHz)	I_{DDB}	4.4	6.1	
			I_{DDA}	3.9	5.8	
		100Mbps (50MHz)	I_{DDB}	18.7	24.8	
			I_{DDA}	4.7	6.8	
		I_{DDB}	41.0	54.7		
CA-IS3841						
Supply Current – Disable	ENA = ENB = 0 V; $V_{IN} = 0V$ (CA-IS3841L); $V_{IN} = V_{DDI}^1$ (CA-IS3841H)	I_{DDA}	1.5	2.4	mA	
		I_{DDB}	2.3	3.6		
	ENA = ENB = 0 V; $V_{IN} = V_{DDI}$ (CA-IS3841L); $V_{IN} = 0V$ (CA-IS3841H)	I_{DDA}	4.1	6.8		
		I_{DDB}	3.2	5.1		
Supply Current – DC Signal	ENA = ENB = V_{DDI} ; $V_{IN} = 0V$ (CA-IS3841L); $V_{IN} = V_{DDI}$ (CA-IS3841H)	I_{DDA}	1.6	2.5		
		I_{DDB}	2.5	3.9		
	ENA = ENB = V_{DDI} ; $V_{IN} = V_{DDI}$ (CA-IS3841L); $V_{IN} = 0V$ (CA-IS3841H)	I_{DDA}	4.2	6.9		
		I_{DDB}	3.5	5.4		
Supply Current – AC Signal	ENA = ENB = V_{DDI} ; All Channels Switching with 50% Duty Cycle Square Wave Clock Input with 5V Amplitude; $C_L = 15$ pF for Each Channel	1Mbps (500kHz)	I_{DDA}	3.3	5.2	
		10Mbps (5MHz)	I_{DDB}	4.1	6.2	
			I_{DDA}	6.9	9.9	
		100Mbps (50MHz)	I_{DDB}	14.0	19.5	
			I_{DDA}	14.3	19.8	
		I_{DDB}	32.5	44.0		
CA-IS3842						
Supply Current – Disable	ENA = ENB = 0 V; $V_{IN} = 0V$ (CA-IS3842L); $V_{IN} = V_{DDI}^1$ (CA-IS3842H)	I_{DDA}	2.2	3.3	mA	
		I_{DDB}	2.2	3.3		
	ENA = ENB = 0 V; $V_{IN} = V_{DDI}$ (CA-IS3842L); $V_{IN} = 0V$ (CA-IS3842H)	I_{DDA}	4.8	7.0		
		I_{DDB}	4.8	7.0		
Supply Current – DC Signal	ENA = ENB = V_{DDI} ; $V_{IN} = 0V$ (CA-IS3842L); $V_{IN} = V_{DDI}$ (CA-IS3842H)	I_{DDA}	2.4	3.5		
		I_{DDB}	2.4	3.5		
	ENA = ENB = V_{DDI} ; $V_{IN} = V_{DDI}$ (CA-IS3842L); $V_{IN} = 0V$ (CA-IS3842H)	I_{DDA}	4.9	7.1		
		I_{DDB}	4.9	7.1		
Supply Current – AC Signal	ENA = ENB = V_{DDI} ; All Channels Switching with 50% Duty Cycle Square Wave Clock Input with 5V Amplitude; $C_L = 15$ pF for Each Channel	1Mbps (500kHz)	I_{DDA}	4.4	6.3	
		10Mbps (5MHz)	I_{DDB}	4.4	6.3	
			I_{DDA}	11.8	16.0	
		100Mbps (50MHz)	I_{DDB}	11.8	16.0	
			I_{DDA}	24.0	33.0	
		I_{DDB}	24.0	33.0		
Note:						
1. V_{DDI} = Input-side V_{DD}						

7.9.2 $V_{DDA} = V_{DDB} = 3.3\text{ V} \pm 10\%$, $T_A = -40^\circ\text{C}$ to 125°C

PARAMETER	TEST CONDITION	SUPPLY CURRENT	MIN	TYP	MAX	UNIT
CA-IS3840						
Supply Current – Disable	ENB = 0 V; $V_{IN} = 0\text{V}$ (CA-IS3840L); $V_{IN} = V_{DDA}$ (CA-IS3840H)	I_{DDA}	1.4	2.0		mA
		I_{DDB}	2.4	3.5		
	ENB = 0 V; $V_{IN} = V_{DDA}$ (CA-IS3840L); $V_{IN} = 0\text{V}$ (CA-IS3840H)	I_{DDA}	6.3	9.5		
		I_{DDB}	2.4	3.6		
Supply Current – DC Signal	ENB = V_{DDB} ; $V_{IN} = 0\text{V}$ (CA-IS3840L); $V_{IN} = V_{DDA}$ (CA-IS3840H)	I_{DDA}	1.4	2.0		
		I_{DDB}	2.6	3.7		
	ENB = V_{DDB} ; $V_{IN} = V_{DDA}$ (CA-IS3840L); $V_{IN} = 0\text{V}$ (CA-IS3840H)	I_{DDA}	6.2	9.3		
Supply Current – AC Signal	ENB = V_{DDB} ; All Channels Switching with 50% Duty Cycle Square Wave Clock Input with 5V Amplitude; $C_L = 15$ pF for Each Channel	1Mbps (500kHz)	I_{DDA}	3.8	5.7	
		10Mbps (5MHz)	I_{DDB}	3.7	5.1	
			I_{DDA}	3.8	5.7	
		100Mbps (50MHz)	I_{DDB}	13.2	17.5	
			I_{DDA}	4.6	6.8	
		I_{DDB}	28.7	38.3		
CA-IS3841						
Supply Current – Disable	ENA = ENB = 0 V; $V_{IN} = 0\text{V}$ (CA-IS3841L); $V_{IN} = V_{DDI}^1$ (CA-IS3841H)	I_{DDA}	1.5	2.4		mA
		I_{DDB}	2.3	3.5		
	ENA = ENB = 0 V; $V_{IN} = V_{DDI}$ (CA-IS3841L); $V_{IN} = 0\text{V}$ (CA-IS3841H)	I_{DDA}	4.0	6.7		
		I_{DDB}	3.2	5.1		
Supply Current – DC Signal	ENA = ENB = V_{DDI} ; $V_{IN} = 0\text{V}$ (CA-IS3841L); $V_{IN} = V_{DDI}$ (CA-IS3841H)	I_{DDA}	1.5	2.4		
		I_{DDB}	2.4	3.7		
	ENA = ENB = V_{DDI} ; $V_{IN} = V_{DDI}$ (CA-IS3841L); $V_{IN} = 0\text{V}$ (CA-IS3841H)	I_{DDA}	4.1	6.8		
Supply Current – AC Signal	ENA = ENB = V_{DDI} ; All Channels Switching with 50% Duty Cycle Square Wave Clock Input with 5V Amplitude; $C_L = 15$ pF for Each Channel	1Mbps (500kHz)	I_{DDA}	3.0	4.9	
		10Mbps (5MHz)	I_{DDB}	3.6	5.4	
			I_{DDA}	5.5	8.0	
		100Mbps (50MHz)	I_{DDB}	10.0	13.9	
			I_{DDA}	10.3	14.5	
		I_{DDB}	21.9	29.7		
CA-IS3842						
Supply Current – Disable	ENA = ENB = 0 V; $V_{IN} = 0\text{V}$ (CA-IS3842L); $V_{IN} = V_{DDI}^1$ (CA-IS3842H)	I_{DDA}	2.3	3.2		mA
		I_{DDB}	2.3	3.2		
	ENA = ENB = 0 V; $V_{IN} = V_{DDI}$ (CA-IS3842L); $V_{IN} = 0\text{V}$ (CA-IS3842H)	I_{DDA}	4.9	6.9		
		I_{DDB}	4.9	6.9		
Supply Current – DC Signal	ENA = ENB = V_{DDI} ; $V_{IN} = 0\text{V}$ (CA-IS3842L); $V_{IN} = V_{DDI}$ (CA-IS3842H)	I_{DDA}	2.4	3.3		
		I_{DDB}	2.4	3.3		
	ENA = ENB = V_{DDI} ; $V_{IN} = V_{DDI}$ (CA-IS3842L); $V_{IN} = 0\text{V}$ (CA-IS3842H)	I_{DDA}	5.0	7.0		
Supply Current – AC Signal	ENA = ENB = V_{DDI} ; All Channels Switching with 50% Duty Cycle Square Wave Clock Input with 5V Amplitude; $C_L = 15$ pF for Each Channel	1Mbps (500kHz)	I_{DDA}	4.0	5.9	
		10Mbps (5MHz)	I_{DDB}	4.0	5.9	
			I_{DDA}	8.9	12.0	
		100Mbps (50MHz)	I_{DDB}	8.9	12.0	
			I_{DDA}	17.4	24.0	
		I_{DDB}	17.4	24.0		
Note:						
1. V_{DDI} = Input-side V_{DD}						

7.9.3 $V_{DDA} = V_{DDB} = 2.5 V \pm 5\%$, $T_A = -40^{\circ}C$ to $125^{\circ}C$

PARAMETER	TEST CONDITION	SUPPLY CURRENT	MIN	TYP	MAX	UNIT
CA-IS3840						
Supply Current – Disable	ENB = 0 V; $V_{IN} = 0V$ (CA-IS3840L); $V_{IN} = V_{DDA}$ (CA-IS3840H)	I_{DDA}	1.4	2.0		mA
		I_{DDB}	2.4	3.4		
	ENB = 0 V; $V_{IN} = V_{DDA}$ (CA-IS3840L); $V_{IN} = 0V$ (CA-IS3840H)	I_{DDA}	6.3	9.3		
		I_{DDB}	2.4	3.5		
Supply Current – DC Signal	ENB = V_{DDB} ; $V_{IN} = 0V$ (CA-IS3840L); $V_{IN} = V_{DDA}$ (CA-IS3840H)	I_{DDA}	1.4	2.0		
		I_{DDB}	2.5	3.6		
	ENB = V_{DDB} ; $V_{IN} = V_{DDA}$ (CA-IS3840L); $V_{IN} = 0V$ (CA-IS3840H)	I_{DDA}	6.3	9.3		
		I_{DDB}	2.5	3.7		
Supply Current – AC Signal	ENB = V_{DDB} ; All Channels Switching with 50% Duty Cycle Square Wave Clock Input with 5V Amplitude; $C_L = 15$ pF for Each Channel	1Mbps (500kHz)	I_{DDA}	3.8	5.6	
			I_{DDB}	3.4	4.7	
		10Mbps (5MHz)	I_{DDA}	3.8	5.6	
			I_{DDB}	10.6	14.1	
		100Mbps (50MHz)	I_{DDA}	4.7	7.0	
			I_{DDB}	22.4	30.0	
CA-IS3841						
Supply Current – Disable	ENA = ENB = 0 V; $V_{IN} = 0V$ (CA-IS3841L); $V_{IN} = V_{DDI}^1$ (CA-IS3841H)	I_{DDA}	1.5	2.3		mA
		I_{DDB}	2.3	3.5		
	ENA = ENB = 0 V; $V_{IN} = V_{DDI}$ (CA-IS3841L); $V_{IN} = 0V$ (CA-IS3841H)	I_{DDA}	4.0	6.7		
		I_{DDB}	3.2	5.0		
Supply Current – DC Signal	ENA = ENB = V_{DDI} ; $V_{IN} = 0V$ (CA-IS3841L); $V_{IN} = V_{DDI}$ (CA-IS3841H)	I_{DDA}	1.5	2.4		
		I_{DDB}	2.4	3.7		
	ENA = ENB = V_{DDI} ; $V_{IN} = V_{DDI}$ (CA-IS3841L); $V_{IN} = 0V$ (CA-IS3841H)	I_{DDA}	4.0	6.7		
		I_{DDB}	3.3	5.1		
Supply Current – AC Signal	ENA = ENB = V_{DDI} ; All Channels Switching with 50% Duty Cycle Square Wave Clock Input with 5V Amplitude; $C_L = 15$ pF for Each Channel	1Mbps (500kHz)	I_{DDA}	3.0	4.8	
			I_{DDB}	3.4	5.1	
		10Mbps (5MHz)	I_{DDA}	4.8	7.2	
			I_{DDB}	8.3	11.5	
		100Mbps (50MHz)	I_{DDA}	8.4	11.9	
			I_{DDB}	16.7	22.9	
CA-IS3842						
Supply Current – Disable	ENA = ENB = 0 V; $V_{IN} = 0V$ (CA-IS3842L); $V_{IN} = V_{DDI}^1$ (CA-IS3842H)	I_{DDA}	2.2	3.2		mA
		I_{DDB}	2.2	3.2		
	ENA = ENB = 0 V; $V_{IN} = V_{DDI}$ (CA-IS3842L); $V_{IN} = 0V$ (CA-IS3842H)	I_{DDA}	4.6	6.8		
		I_{DDB}	4.6	6.8		
Supply Current – DC Signal	ENA = ENB = V_{DDI} ; $V_{IN} = 0V$ (CA-IS3842L); $V_{IN} = V_{DDI}$ (CA-IS3842H)	I_{DDA}	2.2	3.2		
		I_{DDB}	2.2	3.2		
	ENA = ENB = V_{DDI} ; $V_{IN} = V_{DDI}$ (CA-IS3842L); $V_{IN} = 0V$ (CA-IS3842H)	I_{DDA}	4.7	6.9		
		I_{DDB}	4.7	6.9		
Supply Current – AC Signal	ENA = ENB = V_{DDI} ; All Channels Switching with 50% Duty Cycle Square Wave Clock Input with 5V Amplitude; $C_L = 15$ pF for Each Channel	1Mbps (500kHz)	I_{DDA}	3.9	5.6	
			I_{DDB}	3.9	5.6	
		10Mbps (5MHz)	I_{DDA}	7.5	10.3	
			I_{DDB}	7.5	10.3	
		100Mbps (50MHz)	I_{DDA}	14.4	19.7	
			I_{DDB}	14.4	19.7	
Note:						
1. V_{DDI} = Input-side V_{DD}						

7.10 Timing Characteristics

7.10.1 $V_{DDA} = V_{DDB} = 5\text{ V} \pm 10\%$, $T_A = -40^\circ\text{C}$ to 125°C

PARAMETER		TEST CONDITIONS	MIN	TYP	MAX	UNIT
DR	Data Rate		0		150	Mbps
PW _{min}	Minimum Pulse Width				5	ns
t _{PLH} , t _{PHL}	Propagation Delay Time	See Figure 8-1		12	15	ns
PWD	Pulse Width Distortion t _{PLH} - t _{PHL}			0.2	4.5	ns
t _{sk(o)}	Channel-to-channel Output Skew Time ¹	Same-direction channels		0.4	2.5	ns
t _{sk(pp)}	Part-to-part Skew Time ²			2.0	4.5	ns
t _r	Output Signal Rise Time	See Figure 8-1		2.5	4.0	ns
t _f	Output Signal Fall Time	See Figure 8-1		2.5	4.0	ns
t _{PHZ}	Disable Propagation Delay, High to High Impedance Output	See Figure 8-2		12	20	ns
t _{PLZ}	Disable Propagation Delay, Low to High Impedance Output			12	20	ns
t _{PZH}	Enable Propagation Delay, High Impedance to High Output			15	25	ns
t _{PZL}	Enable Propagation Delay, High Impedance to Low Output			15	25	ns
t _{DO}	Default Output Delay Time from Input Power Loss	See Figure 8-3		8	12	μs
t _{SU}	Start-up Time			15	40	μs

NOTE:

- t_{sk(o)} is the skew between outputs of a single device with all driving inputs connected together and the outputs switching in the same direction while driving identical loads.
- t_{sk(pp)} is the magnitude of the difference in propagation delay times between any terminals of different devices switching in the same direction while operating at identical supply voltages, temperature, input signals and loads.

7.10.2 $V_{DDA} = V_{DDB} = 3.3\text{ V} \pm 10\%$, $T_A = -40^\circ\text{C}$ to 125°C

PARAMETER		TEST CONDITIONS	MIN	TYP	MAX	UNIT
DR	Data Rate		0		150	Mbps
PW _{min}	Minimum Pulse Width				5	ns
t _{PLH} , t _{PHL}	Propagation Delay Time	See Figure 8-1		12	17	ns
PWD	Pulse Width Distortion t _{PLH} - t _{PHL}			0.2	4.5	ns
t _{sk(o)}	Channel-to-channel Output Skew Time ¹	Same-direction channels		0.4	2.5	ns
t _{sk(pp)}	Part-to-part Skew Time ²			2.0	4.5	ns
t _r	Output Signal Rise Time	See Figure 8-1		2.5	4.0	ns
t _f	Output Signal Fall Time	See Figure 8-1		2.5	4.0	ns
t _{PHZ}	Disable Propagation Delay, High to High Impedance Output	See Figure 8-2		12	20	ns
t _{PLZ}	Disable Propagation Delay, Low to High Impedance Output			12	20	ns
t _{PZH}	Enable Propagation Delay, High Impedance to High Output			15	25	ns
t _{PZL}	Enable Propagation Delay, High Impedance to Low Output			15	25	ns
t _{DO}	Default Output Delay Time from Input Power Loss	See Figure 8-3		8	12	μs
t _{SU}	Start-up Time			15	40	μs

NOTE:

- t_{sk(o)} is the skew between outputs of a single device with all driving inputs connected together and the outputs switching in the same direction while driving identical loads.
- t_{sk(pp)} is the magnitude of the difference in propagation delay times between any terminals of different devices switching in the same direction while operating at identical supply voltages, temperature, input signals and loads.

7.10.3 $V_{DDA} = V_{DDB} = 2.5 V \pm 5\%$, $T_A = -40^{\circ}C$ to $125^{\circ}C$

PARAMETER		TEST CONDITIONS	MIN	TYP	MAX	UNIT
DR	Data Rate		0		150	Mbps
PW_{min}	Minimum Pulse Width				5	ns
t_{PLH} , t_{PHL}	Propagation Delay Time	<i>See Figure 8-1</i>		12	20	ns
PWD	Pulse Width Distortion $ t_{PLH} - t_{PHL} $			0.2	4.5	ns
$t_{sk(o)}$	Channel-to-channel Output Skew Time ¹	Same-direction channels		0.4	2.5	ns
$t_{sk(pp)}$	Part-to-part Skew Time ²			2	5	ns
t_r	Output Signal Rise Time	<i>See Figure 8-1</i>		2.5	4.0	ns
t_f	Output Signal Fall Time	<i>See Figure 8-1</i>		2.5	4.0	ns
t_{PHZ}	Disable Propagation Delay, High to High Impedance Output	<i>See Figure 8-2</i>		12	20	ns
t_{PLZ}	Disable Propagation Delay, Low to High Impedance Output			12	20	ns
t_{PZH}	Enable Propagation Delay, High Impedance to High Output			15	25	ns
t_{PZL}	Enable Propagation Delay, High Impedance to Low Output			15	25	ns
t_{DO}	Default Output Delay Time from Input Power Loss	<i>See Figure 8-3</i>		8	12	μs
t_{SU}	Start-up Time			15	40	μs

NOTE:

- $t_{sk(o)}$ is the skew between outputs of a single device with all driving inputs connected together and the outputs switching in the same direction while driving identical loads.
- $t_{sk(pp)}$ is the magnitude of the difference in propagation delay times between any terminals of different devices switching in the same direction while operating at identical supply voltages, temperature, input signals and loads.

8 Parameter Measurement Information

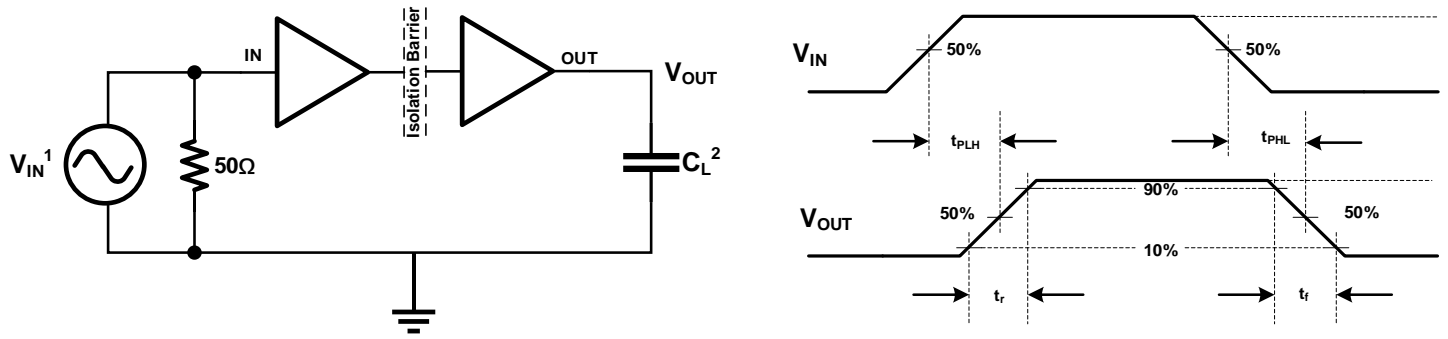

NOTE:

1. A square wave generator generate the V_{IN} input signal with the following constraints: waveform frequency $\leq 100\text{kHz}$, 50% duty cycle, $t_r \leq 3\text{ns}$, $t_f \leq 3\text{ns}$. Since the waveform generator has an output impedance of $Z_{out} = 50\Omega$, the 50Ω resistor in the figure is used for matching. There is no need in the actual application.
2. C_L is the load capacitance about 15pF together with the instrumentation capacitance. Since the load capacitance influence the output rising time, it's a key factor in the timing characteristic measurement.

Figure 8-1 Timing Characteristics Test Circuit and Voltage Waveforms

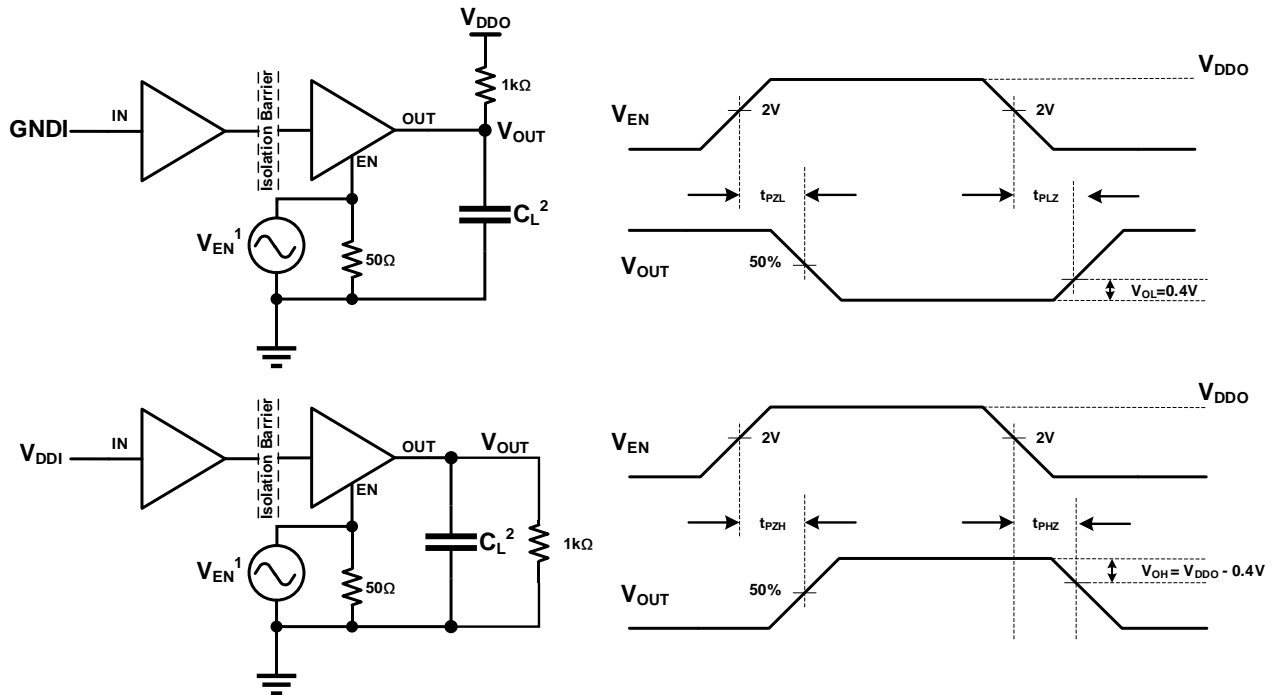

NOTE:

1. A square wave generator generate the V_{EN} input signal with the following constraints: waveform frequency $\leq 100\text{kHz}$, 50% duty cycle, $t_r \leq 3\text{ns}$, $t_f \leq 3\text{ns}$. Since the waveform generator has an output impedance of $Z_{out} = 50\Omega$, the 50Ω resistor in the figure is used for matching. There is no need in the actual application.
2. C_L is the load capacitance about 15pF together with the instrumentation capacitance. Since the load capacitance influence the output rising time, it's a key factor in the timing characteristic measurement.

Figure 8-2 Enable/Disable Propagation Delay Time Test Circuit and Waveform

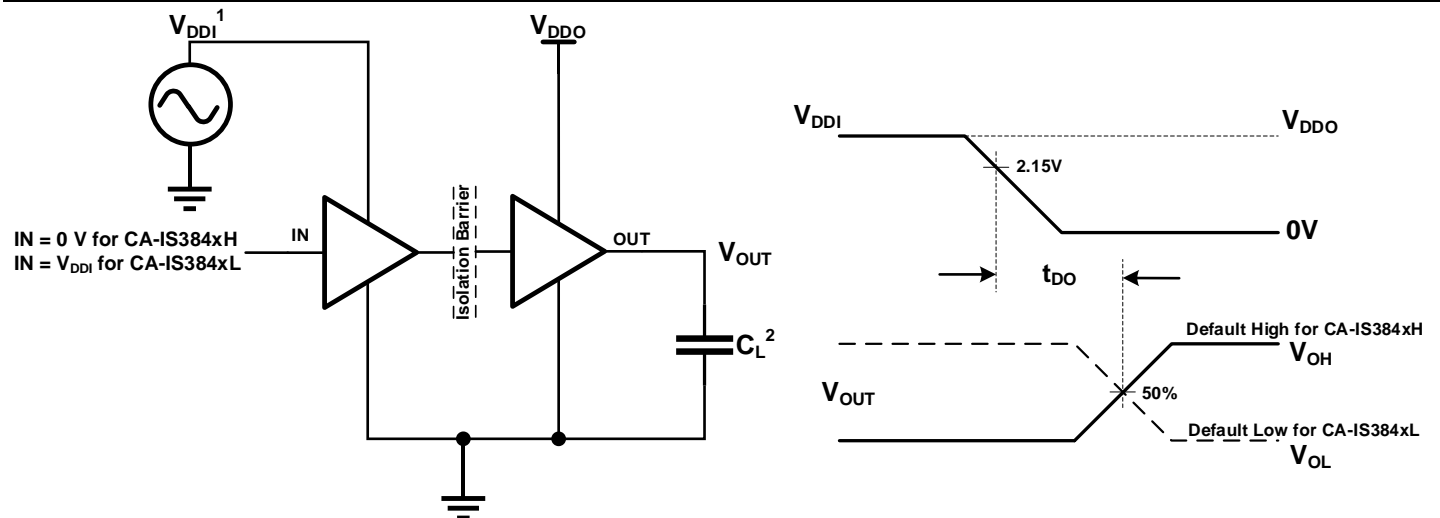

NOTE:

1. Power Supply Ramp Rate = 10 mV/ns. V_{DDI} should ramp over 2.375V but no higher than 5.5V.
2. C_L is the load capacitance about 15pF together with the instrumentation capacitance. Since the load capacitance influence the output rising time, it's a key factor in the timing characteristic measurement.

Figure 8-3 Default Output Delay Time Test Circuit and Voltage Waveforms

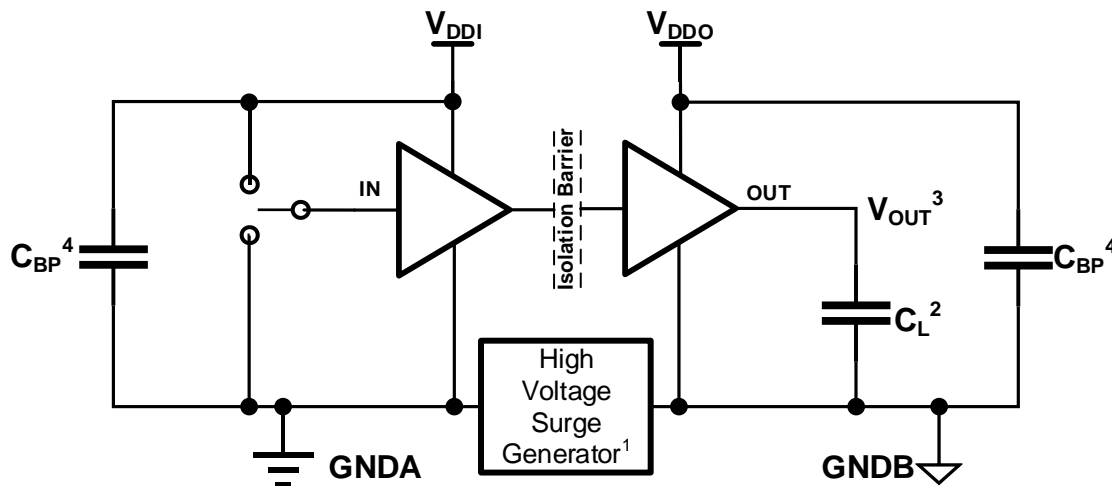

NOTE:

1. The High Voltage Surge Generator generates repetitive high voltage surges with > 1kV amplitude and <10ns rise time and fall time to reach common-mode transient noise with > 150kV/ μ s slew rate.
2. C_L is the load capacitance about 15pF together with the instrumentation capacitance.
3. Pass-fail criteria: The output must remain stable whenever the high voltage surges come.
4. C_{BP} is the 0.1 ~ 1uF bypass capacitance.

Figure 8-4 Common-Mode Transient Immunity Test Circuit

9 Detailed Description

9.1 Theory of Operation

The CA-IS38xx family of devices use a simple ON-OFF keying (OOK) modulation scheme to transmit signal across the SiO₂ isolation capacitors that provide a robust insulation between two different voltage domain and act as a high frequency signal path between the input and the output. The transmitter (TX) modulates the input signal onto the carrier frequency, that is, TX delivers high frequency signal across the isolation barrier in one input state and delivers no signal across the barrier in the other input state. Then the receiver rebuilds the input signal according to the detected in-band energy. This simple architecture offers a robust isolated data path and requires no special considerations or initialization at start-up. The capacitor-based signal path is fully differential to maximize noise immunity, which is also known as common-mode transient immunity. Advanced circuitry techniques are applied for better EMI introduced by the carrier signal and IO switching. The capacitively-coupled architecture provides much higher electromagnetic immunity compared to the inductively-coupled one. And OOK modulation scheme eliminates the missing-pulse error that occurs in the pulse modulation method. A simplified functional block diagram and conceptual operation waveforms of a single channel is shown in Figure 9-1 and Figure 9-2.

9.2 Functional Block Diagram

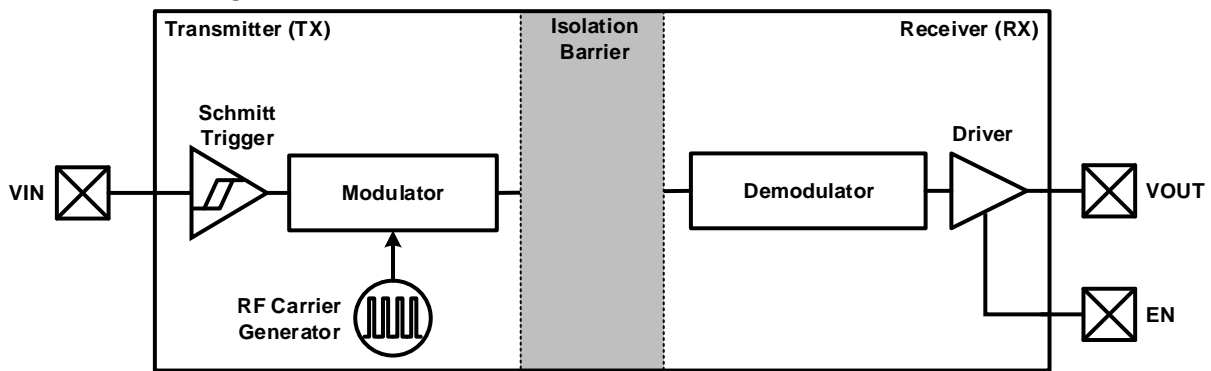

Figure 9-1 Functional Block Diagram of a Single Channel

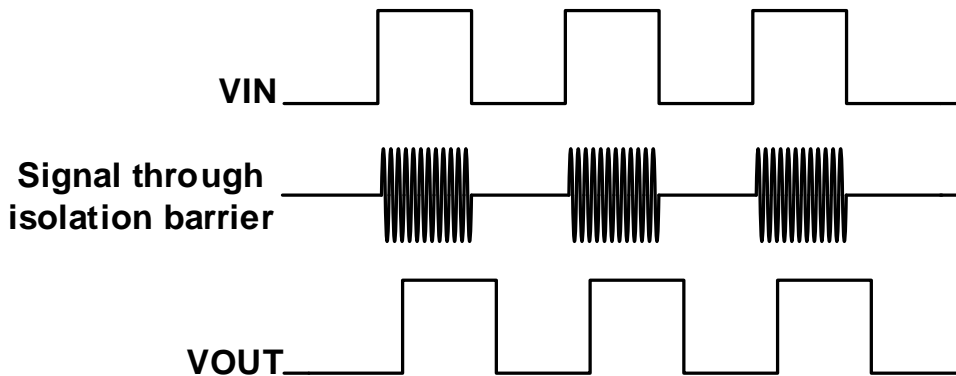

Figure 9-2 Conceptual Operation Waveforms of a Single Channel

9.3 Device Operation Modes

Table 9-1 provides the operation modes for the CA-IS384x devices.

Table 9-1 Operation Mode Table¹

V _{DDI}	V _{DDO}	INPUT(A _x /B _x) ²	OUTPUT ENABLE(EN _x) ^{3,4}	OUTPUT (A _x /B _x)	OPERATION
PU	PU	H	H or Open	H	Normal operation mode: A channel's output follows the input state
		L	H or Open	L	
		Open	H or Open	Default	Default output fail-safe mode: If a channel's input is left open, its output goes to the default value (Low for CA-IS384xL and High for CA-IS384xH).
X	PU	X	L	Z	High impedance mode: If Enable pin is tied to low, the output will be in high-Z mode
PD	PU	X	H or Open	Default	Default output fail-safe mode: If the input side VDD is unpowered, the outputs go in to the default output fail-safe mode (Low for CA-IS384xL and High for CA-IS384xH)
X	PD	X	X	Undetermined	If the output side VDD is unpowered, the outputs' states are undetermined. ⁵

NOTE:

- V_{DDI} = Input-side VDD; V_{DDO} = Output-side VDD; PU = Powered up (VCC ≥ 2.375 V); PD = Powered down (VCC ≤ 2.25 V); X = Irrelevant; H = High level; L = Low level; Z = High Impedance.
- A strongly driven input signal can weakly power the floating V_{DD} through an internal protection diode and cause undetermined output.
- It is recommended that the enable inputs be connected to an external logic high or low level when the CA-IS384x is operating in noisy environments.
- No Connect (NC) replaces ENA on CA-IS3840. No Connects are not internally connected and can be left floating, tied to VDD, or tied to GND.
- The outputs are in undetermined state when 2.25V < V_{DDI}, V_{DDO} < 2.375 V.

Table 9-2 provides the Enable input truth table for the CA-IS384x devices.

Table 9-2 Enable Input Truth Table

PART NUMBER	ENA ^{1,2}	ENB ^{1,2}	OPERATION
CA-IS3840	—	H	Outputs VO1, VO2, VO3, VO4 are enabled and follow the input state.
	—	L	Outputs VO1, VO2, VO3, VO4 are disabled and in high impedance state.
CA-IS3841	H	X	Output VO4 enabled and follows the input state.
	L	X	Output VO4 disabled and in high impedance state.
	X	H	Outputs VO1, VO2, VO3 are enabled and follow the input state.
	X	L	Outputs VO1, VO2, VO3 are disabled and in high impedance state.
CA-IS3842	H	X	Outputs VO3 and VO4 are enabled and follow the input state.
	L	X	Outputs VO3 and VO4 are disabled and in high impedance state.
	X	H	Outputs VO1 and VO2 are enabled and follow the input state.
	X	L	Outputs VO1 and VO2 are disabled and in high impedance state.

NOTE:

- Enable inputs ENA and ENB can be used for multiplexing, for clock sync, or other output control. ENA, ENB logic operation is summarized for each isolator product in Table 9-2. These inputs are internally pulled-up to local VDD allowing them to be connected to an external logic level (high or low) or left floating. To minimize noise coupling, do not connect circuit traces to ENA or ENB if they are left floating. If ENA, ENB are unused, it is recommended they be connected to an external logic level, especially if the CA-IS384x is operating in a noisy environment.
- X = Irrelevant; H = High level; L = Low level.

10 Application and Implementation

Unlike optocouplers, which need external components to improve performance, provide bias, or limit current, the CA-IS384x family device CMOS digital isolator needs only two external VDD bypass capacitors (0.1μF to 1 μF) to operate. Its TTL level compatible input terminals draw only micro amps of leakage current, allowing them to be driven without external buffering circuits. The output terminals have a characteristic impedance of 50 Ω (rail-to-rail swing) and are available in both forward and reverse channel configurations. Figure 10-1 shows the typical application of CA-IS3842 device. And the circuit of Figure 10-2 is typical for most applications of CA-IS38xx series products and is as easy to use as a standard logic gate.

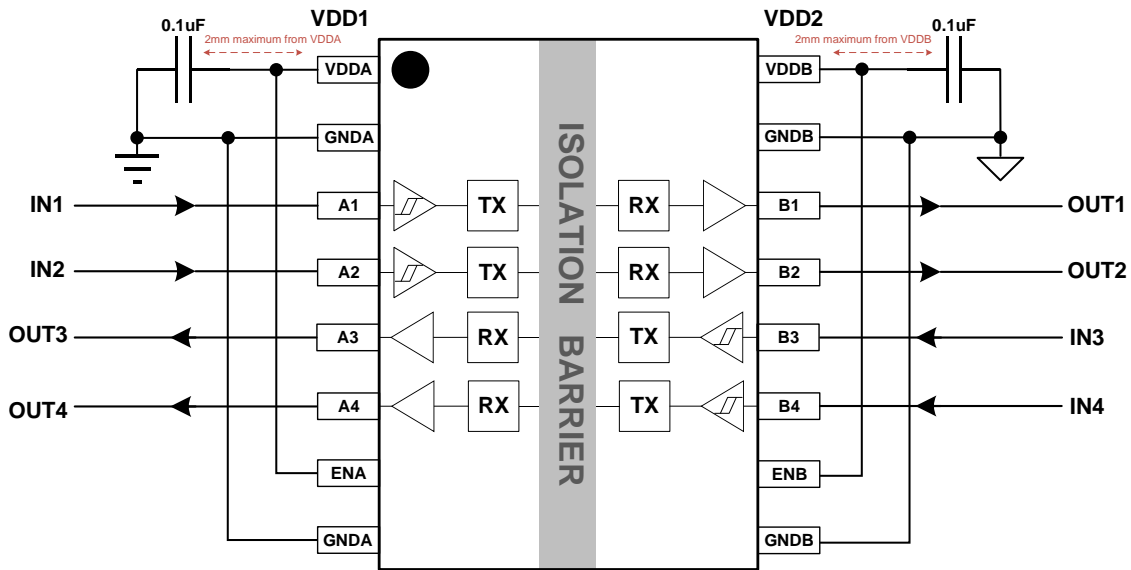

Figure 10-1 Typical Application Circuit of CA-IS3842

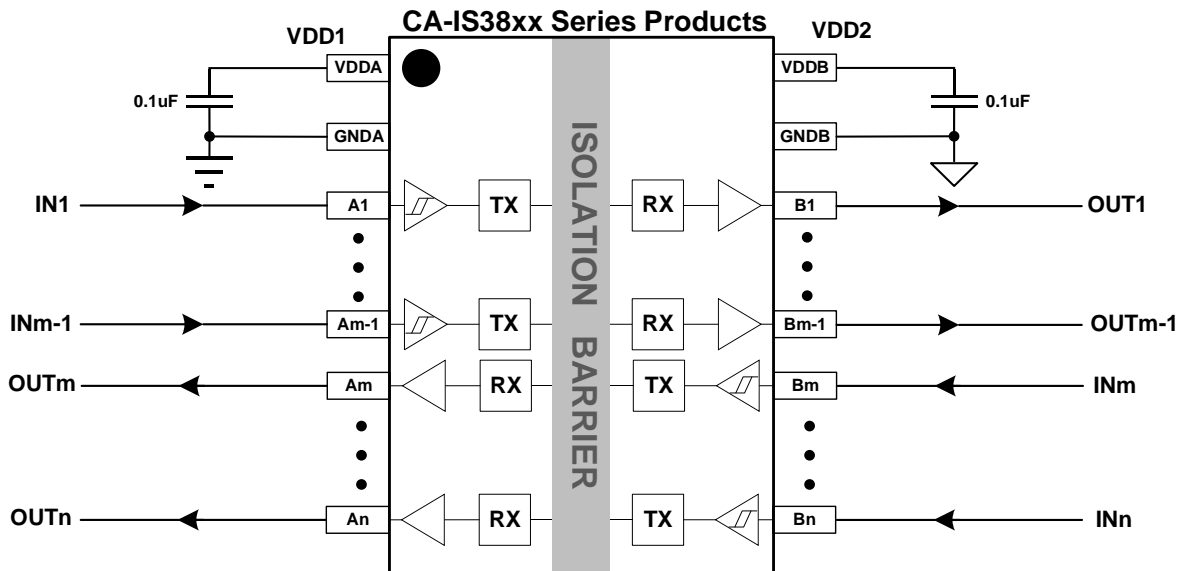
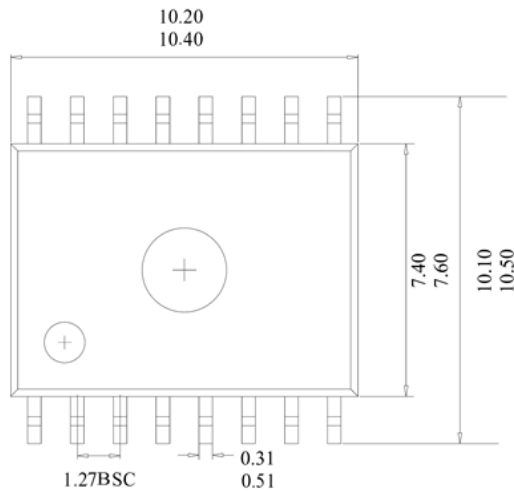

Figure 10-2 CA-IS38xx Series Digital Isolator Application Schematic

11 Package Information

11.1 16-Pin Wide Body SOIC Package(10.30 mm × 7.50 mm)

The figure below illustrates the package details and the recommended land pattern details for the CA-IS384x digital isolator in a 16-pin wide-body SOIC package. The values for the dimensions are shown in millimeters.



TOP VIEW

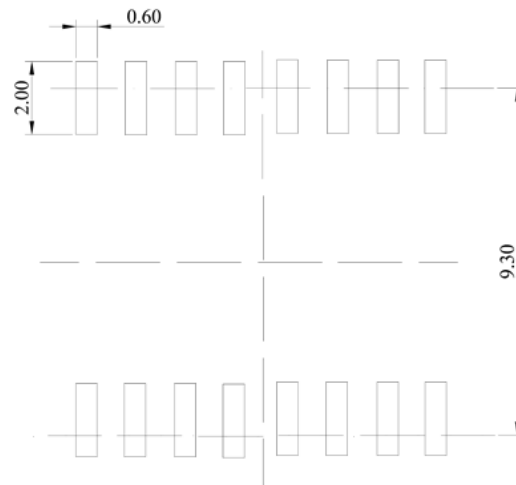

RECOMMENDED LAND PATTERN

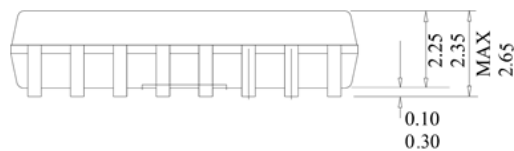

FRONT VIEW

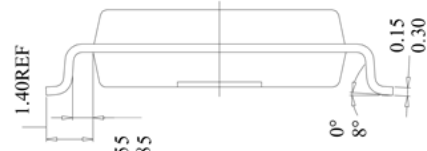

SIDE VIEW

11.2 16-Pin Extra Wide Body SOIC Package (10.30 mm × 14.00 mm)

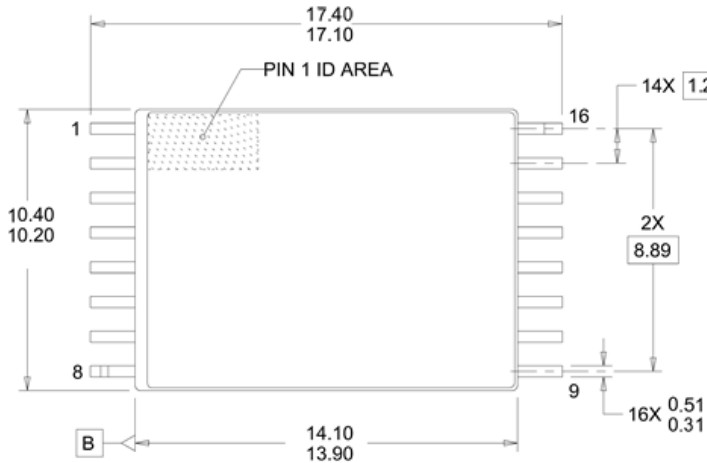

TOP VIEW

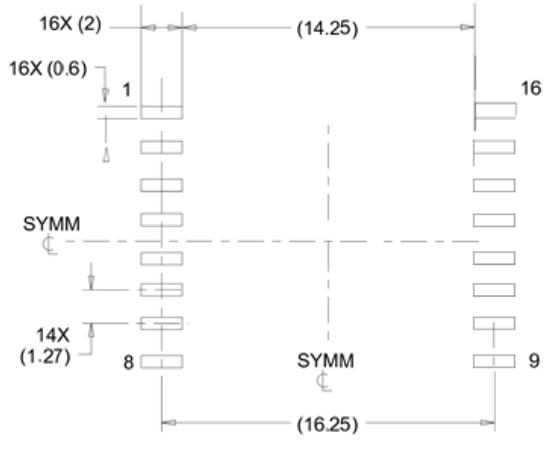

STANDARD
RECOMMENDED LAND PATTERN



FRONT VIEW



SIDE VIEW

12 Soldering Information

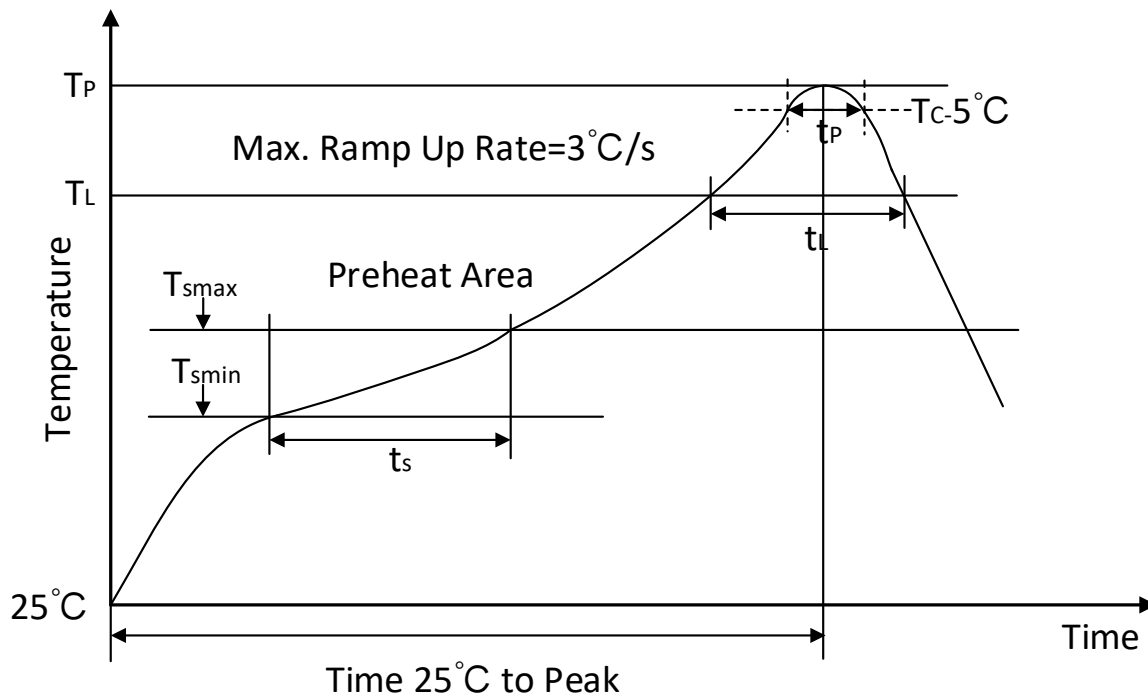
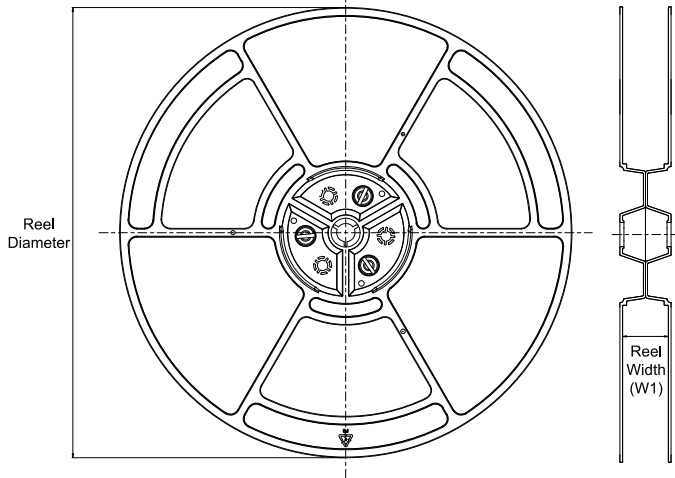
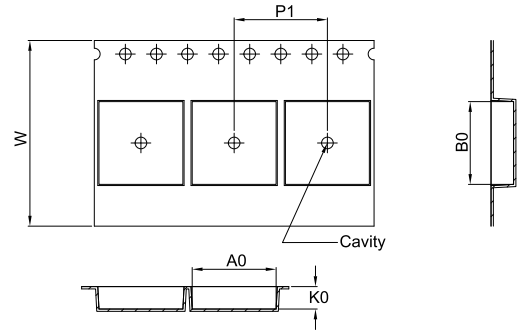

Figure12- 1 Soldering Temperature (reflow) Profile

Table12- 1 Soldering Temperature Parameter

Profile Feature	Pb-Free Assembly
Average ramp-up rate(217 °C to Peak)	3°C /second max
Time of Preheat temp(from 150 °C to 200 °C)	60-120 second
Time to be maintained above 217 °C	60-150 second
Peak temperature	260 °C
Time within 5°C of actual peak temp	30 second
Ramp-down rate	6 °C /second max.
Time from 25°C to peak temp	8 minutes max

13 Tape And Reel Information
REEL DIMENSIONS

TAPE DIMENSIONS

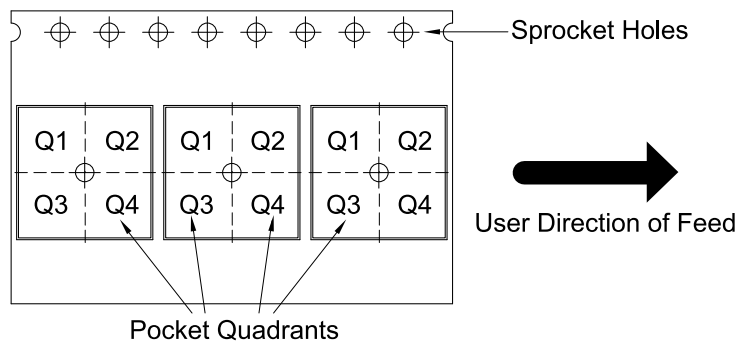
A0	Dimension designed to accommodate the component width
B0	Dimension designed to accommodate the component length
K0	Dimension designed to accommodate the component thickness
W	Overall width of the carrier tape
P1	Pitch between successive cavity centers

QUADRANT ASSIGNMENTS FOR PIN 1 ORIENTATION IN TAPE

*All dimensions are nominal

Device	Package Type	Package Drawing	Pins	SPQ	Reel Diameter (mm)	Reel Width W1 (mm)	A0 (mm)	B0 (mm)	K0 (mm)	P1 (mm)	W (mm)	Pin1 Quadrant
CA-IS3840LW	SOIC	W	16	1000	330	16.4	10.9	10.7	3.2	12.0	16.0	Q1
CA-IS3840HW	SOIC	W	16	1000	330	16.4	10.9	10.7	3.2	12.0	16.0	Q1
CA-IS3841LW	SOIC	W	16	1000	330	16.4	10.9	10.7	3.2	12.0	16.0	Q1
CA-IS3841HW	SOIC	W	16	1000	330	16.4	10.9	10.7	3.2	12.0	16.0	Q1
CA-IS3842LW	SOIC	W	16	1000	330	16.4	10.9	10.7	3.2	12.0	16.0	Q1
CA-IS3842HW	SOIC	W	16	1000	330	16.4	10.9	10.7	3.2	12.0	16.0	Q1
CA-IS3840LWW	SOIC	WW	16	1000	330	24.4	17.6	10.8	3.0	20.0	24.0	Q1
CA-IS3840HWW	SOIC	WW	16	1000	330	24.4	17.6	10.8	3.0	20.0	24.0	Q1
CA-IS3841LWW	SOIC	WW	16	1000	330	24.4	17.6	10.8	3.0	20.0	24.0	Q1
CA-IS3841HWW	SOIC	WW	16	1000	330	24.4	17.6	10.8	3.0	20.0	24.0	Q1
CA-IS3842LWW	SOIC	WW	16	1000	330	24.4	17.6	10.8	3.0	20.0	24.0	Q1
CA-IS3842HWW	SOIC	WW	16	1000	330	24.4	17.6	10.8	3.0	20.0	24.0	Q1

14 Important Notice

The above information is for reference only and is used to assist Chipanalog customers in design and development. Chipanalog reserves the right to change the above information due to technological innovation without prior notice.

Chipanalog products are all factory tested. The customers shall be responsible for self-assessment and determine whether it is applicable for their specific application. Chipanalog's authorization to use the resources is limited to the development of related applications that the Chipanalog products involved in. In addition, the resources shall not be copied or displayed. And Chipanalog shall not be liable for any claim, cost, and loss arising from the use of the resources.

Trademark Information

Chipanalog Inc. ®, Chipanalog® are trademarks or registered trademarks of Chipanalog.



<http://www.chipanalog.com>